

# 2015 PARTS CATALOG

 TOHATSU

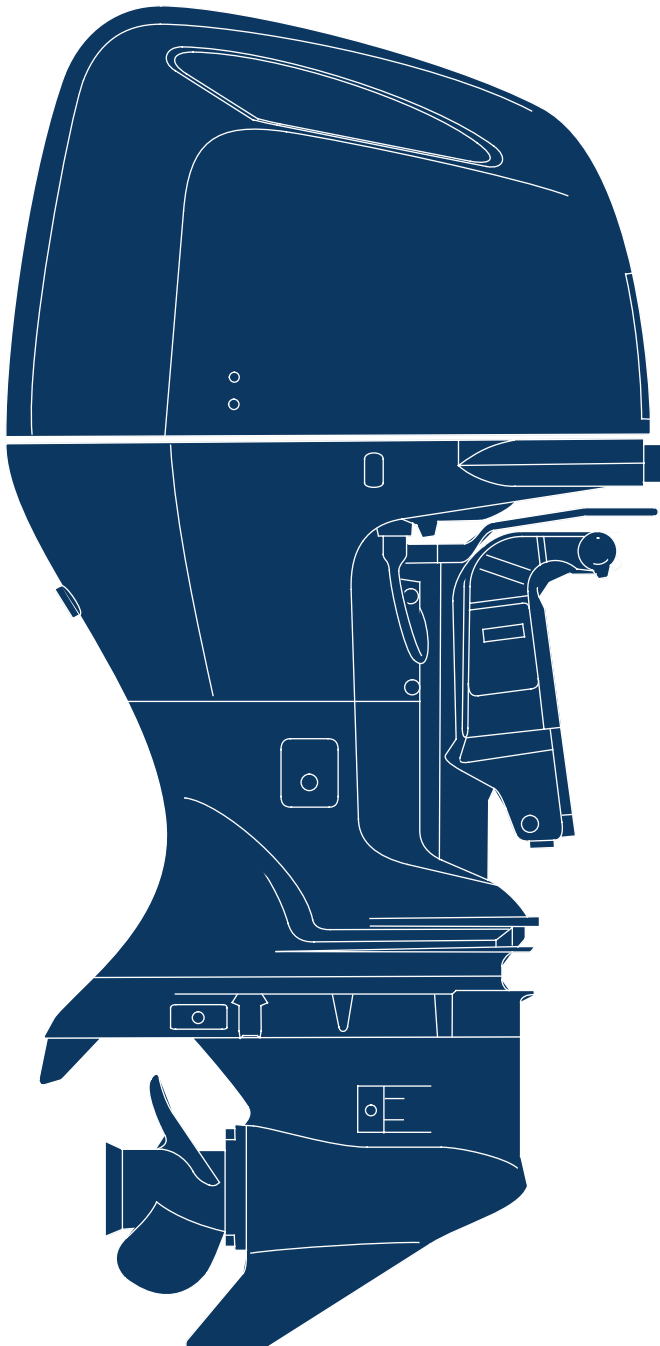

## BFT 250A

OB NO.002-13ZX2-1  
1411EU/EX



# Instruction for use of parts catalogue

- **This parts catalogue was prepared based on the latest information available as of October 1, 2014.**
- See the Service Bulletin for any revision that is made after October 1, 2014.
- **Always specify the part number when ordering a part.**
  - Check the model, type, serial numbers, color, maker, and the size as needed before ordering a part.
  - Note that the illustrations (part drawings) can differ from the actual parts in shape.  
Illustrations are given just to help you to refer to the parts.
- **When modifications or additions to this parts catalogue are made, a revised edition will be issued at an appropriate time, with successively progressing revision numbers on the cover. We recommend obtaining such revisions in order to keep your parts catalogue up-to-date at all times.**

**Initial version issue date October 1, 2014**

## CONTENTS

E-1	CYLINDER HEAD COVER	1
E-3	CYLINDER BLOCK	3
E-3-10	CRANKCASE	7
E-4	EXHAUST MANIFOLD/THERMOSTAT	9
E-5	OIL PUMP/FLYWHEEL	11
E-6	OIL PAN	13
E-6-10	MOUNT CASE	15
E-6-20	MOUNT CASE BOLT	19
E-7	CRANKSHAFT/PISTON	21
E-9	CYLINDER HEAD	25
E-9-10	CAMSHAFT/ROCKER ARM	27
E-13	TIMING BELT	29
E-13-10	TIMING BELT COVER	33
E-14	FUEL PIPE/INJECTOR	35
E-14-10	INTAKE MANIFOLD	39
E-15	THROTTLE BODY	41
E-18	VAPOR SEPARATOR ASSY	43
E-18-1	WATER SEPARATOR/FUEL STRAINER	47
E-18-10	PIPING	51
E-19	A.C.GENERATOR	53
E-20	SPARK PLUG	55
E-20-10	ELECTRONIC CONTROL UNIT	57
E-21	STARTER MOTOR	59
F-2	SHIFT SHAFT	63
F-3	GEAR CASE	67
F-3-10	GEAR CASE ASSY	69
F-3-20	EXTENSION CASE	71
F-4	WATER PUMP/VERTICAL SHAFT	75
F-5	PROPELLER SHAFT	79
F-6	FUEL TUBE	83
F-7	WIRE HARNESS	85
F-7-10	STARTER CABLE	87
F-7-20	FUSE BOX/RELAY	89
F-8	ENGINE COVER	91
F-8-10	FR.COVER BRACKET/FR.LOCK SHAFT	93
F-8-20	FUEL TUBE (2)	97
F-10	STERN BRACKET/SWIVEL CASE	99
F-11	POWER TRIM-TILT	105
F-12	LABEL	109
F-13	TOOL	111
FOP-1	REMOTE CONTROL (TOP MOUNT SINGLE TYPE) (RIGHT)	113
FOP-1-2	REMOTE CONTROL (TOP MOUNT DUAL TYPE) (RIGHT)	117
FOP-1-4	REMOTE CONTROL (FLUSH MOUNT TYPE) (RIGHT)	121
FOP-1-6	REMOTE CONTROL	123
FOP-3	METER	129
FOP-5	BOLT KIT	131
FOP-6	SWITCH PANEL KIT	133
FOP-7	CONTROL PANEL (1)	135
FOP-7-1	CONTROL PANEL (2)	137
FOP-8	RIGGING HOSE KIT	139
FOP-9	TRIM ADJUST PLATE SET	141
FOP-10	INTERFACE CABLE KIT	143
FOP-12	PROPELLER	145
FOP-13	PANEL INTERFACE CABLE SET	147
FOP-14	GEAR CASE KIT	149
INDEX		151
INDEX (Parts Number)		157



# How to refer to the part information

## A. Reference with "Illustrated index"

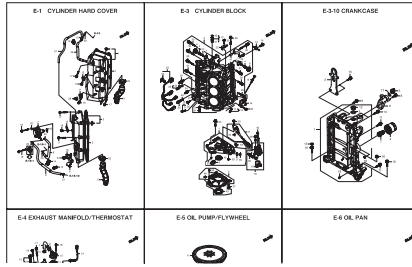
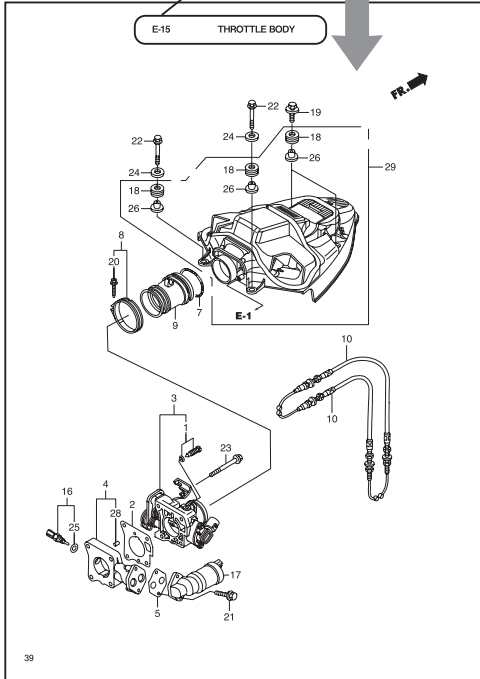

Fig. Number

Ref. Number/Part Number/Parts Name



Ref.No.	Part No.	Description	Q'ty (if 2/3/4)	Remarks
E-15	1	H2Y-18116-003	SCREEN SET	1
E-15	2	H2Y-18116-000	GASKET, THROTTLE BODY	1
E-15	3	H2Y-1840-001	THROTTLE BODY ASSY.	1
E-15	4	H2Z-1840-000	SPACER, THROTTLE BODY	1
E-15	5	H2Y-18405-000	GASKET, EAC VALVE	1
E-15	7	HPY-1549-000	SPRING, AIR FLOW TUBE	1
E-15	8	H2Y-1710-000	BAND, AIR FLOW	1
E-15	9	H2Z-1710-000	CROWMET, SILENCER	1
E-15	10	H2Y-1710-013	CABLE COMP, THROTTLE	2
E-15	14	H2H-3565-000	SENSOR ASSY, AIR TEMP	1
E-15	17	H2Y-3830-000	VALVE ASSY, EAC	1
E-15	18	H2Y-4102-000	CROWMET, UNDER CASE	4
E-15	18	H2H-18013-000	BOLT-WASHER, EX25	2
E-15	20	H2Y-46011-000	BOLT-WASHER, EX30	1
E-15	21	H2Y-46020-000	BOLT, FLANGE, EX22	2
E-15	22	H2Y-46024-000	BOLT, FLANGE, EX30	2
E-15	23	H2Y-46031-000	BOLT, FLANGE, EX35	4
E-15	24	H2Y-46038-000	WASHER, FLANK, EXM	2
E-15	25	HPDM-9133-002	O-RING	1
E-15	26	H2Y-91553-010	COLLAR, C.O.I UNIT CASE	4
E-15	28	H2D-9421-00100	DOBEL, PIN, EX10	2
E-15	29	H2Z-18540-010	COVER ASSY, COOLING FAN	1

## B. Reference with "Parts number index"

INDEX (Parts Number)					
102-31550-0	1315	346-64805-0	11A-203	309-62433-1	13-44
306-00110-0	47	346-64806-0	11B-204	309-64281-0	11B-103
306-00720-0	5-20	346-64211-0	11B-21	309-64482-1	11B-102
306-00720-0	8-12	346-64212-0	11B-26	309-64586-0	8-31
306-00720-0	9-36	346-64213-0	11B-15	309-64587-0	8-32
306-00822-0	9-40	346-64214-0	11B-18	309-64588-0	10-5
312-00002-0	2-36	346-64215-0	11B-15	309-70200-0	16-13
312-00002-0	11A-3	346-64216-0	11A-15-2	398-00520-0	16-27
312-00000-0	3-25	346-64217-0	11A-15-3	398-00521-0	8-54
312-00000-0	11A-4	346-64218-0	24-74	398-02296-1	12-18
312-00000-0	24-62	346-64219-0	11A-12	398-02297-1	12-3
312-00100-0	11B-8	346-64220-0	11A-12	398-70201-0	16-26
312-00100-0	25-63	346-64221-0	11A-21	398-70202-0	24-10
312-00101-0	2-28	346-64222-0	11A-22	346-70203-0	2-28
312-00101-0	13-47	346-64223-0	11A-23	346-70204-0	7-24
312-00210-0	11B-16	346-64224-0	11A-27	346-70205-0	8-24
312-00220-0	11A-16	346-64225-0	24-70	346-70206-0	9-43
312-00220-0	24-63	346-64226-0	12-46	343-00830-0	22-9
312-00210-0	11A-13	346-64227-0	12-61	343-00831-0	12-47
312-00210-0	20-11	346-64228-0	12-82-2	343-72960-0	22-5
312-00210-0	12-84	346-64229-0	12-22	343-72961-0	22-7
346-01110-0	8-3	346-64230-0	12-74	343-73017-0	8-20-1
346-01130-0	11A-24	346-64231-0	12-32	343-73018-0	8-20-2
346-00720-0	15-23	346-01110-0	8-21	343-73019-0	8-20
346-00720-0	23-41-2	346-01120-0	8-22	343-73020-0	8-20
346-00870-0	23-47	346-01130-0	8-23	343-73021-0	8-20
		346-01141-0	8-25	343-73022-1	22-11

## C. Reference with "Parts name index"

INDEX				
<A>	ADJUST SCREW	21-28	BOCT	9-63
	ADJUSTING NUT	1-8	BOCT	10-20
	ADJUSTING SCREW	1-8	BOCT	10-20
	ADJUSTING SCREW	15-12	BOCT	10-34
	AIR FILTER	5-60	BOCT	10-20
	AIR VENT ASSY	6-47	BOCT	11A-2
	ALTERNATOR ASSY	8-2	BOCT	11A-23
	ANODE	1-14	BOCT	11A-35
	ANODE	1-21	BOCT	11A-35
	ANODE	1-15	BOCT	11A-39
	ANODE FLANG	1-12	BOCT	11B-8
	APRCH	10-20	BOCT	12-4
	ARMOR COVER(BLU)-200	21-46-2	BOCT	12-4
	ARMOR COVER(BLU)-200	21-46-1	BOCT	12-4
	ARMOR COVER(BLU)-200	21-32	BOCT	12-20
	ARMOR COVER(BLU)-200	21-46-3	BOCT	12-4
<B>	BACK-UP RING	14-14	BOCT	12-40
	BALL BEARING	14-21	BOCT	12-50
	BALL BEARING	11B-30	BOCT	12-40
	BALL BEARING G.205	11B-5	BOCT	12-40
	BALL CART CONNECTOR	17-22	BOCT	12-40
	BAND 104	22-17	BOCT	13-4
	BAND 104	8-26	BOCT	12-40
	BAND 104	8-30	BOCT	13-19
	BAND 104	6-75	BOCT	14-26
	BAND 104	8-31	BOCT	14-32

# Part catalogue structure

Part No.	Part No.	Description	Q ty	Remarks
E-15	HCY3-16018-000	SCREW SET	1	
E-15	HCY3-16178-000	GASKET, THROTTLE BODY	1	
E-15	HCY3-16400-001	THROTTLE BODY ASSY.	1	
E-15	HCX2-16404-000	SPACER, THROTTLE BODY	1	
E-15	HCY3-16405-000	GASKET, EAC VALVE	1	
E-15	HPY3-11248-000	SPRING, AIR FLOW TUBE	1	
E-15	HCY3-11315-000	BAND, AIR FLOW	1	
E-15	HCX2-11314-000	GROMMET, SLENDER	1	
E-15	HCY3-11910-010	CABLE COMP., THROTTLE	2	
E-15	HQW6-35465-003	SENSOR ASSY., AIR TEMP	1	
E-15	HCY3-30200-003	VALVE ASSY., EAC	1	
E-15	HCY3-40102-000	GROMMET, UNDER CASE	4	
E-15	HQW1-80010-000	BOLT-WASHER, BX25	2	
E-15	HCY3-80017-000	BOLT-WASHER, BX30	1	
E-15	HCY3-80030-000	BOLT, FLANGE, BX32	2	
E-15	HCY3-80034-000	BOLT, FLANGE, BX40	2	
E-15	HCY3-80037-000	BOLT, FLANGE, BX45	4	
E-15	HCY3-90030-000	WASHER, PLAN, 6MM	2	
E-15	HR04-11303-002	O-RING	1	
E-15	HCY3-01501-010	COLLAR, COLLUMET CASE	4	
E-15	HQD-84301-08100	DOMEL PIN, 6X10	2	
E-15	HCX2-19540-010	COVER ASSY., COOLING FAN	1	

- ① Fig. Number
- ② Fig. Title
- ③ Ref. Number
- ④ Parts Number
- ⑤ Parts Name
- ⑥ Q.ty
- ⑦ Remarks
- ⑧ Defferent specification
- ⑨ Direction Arrow
- ⑩ Parts enclosed within a dotted line are sub assembly parts.
- ⑪ A solid arrow indicates the block No. the part in question is connected to.

# How to check the part block and serial numbers

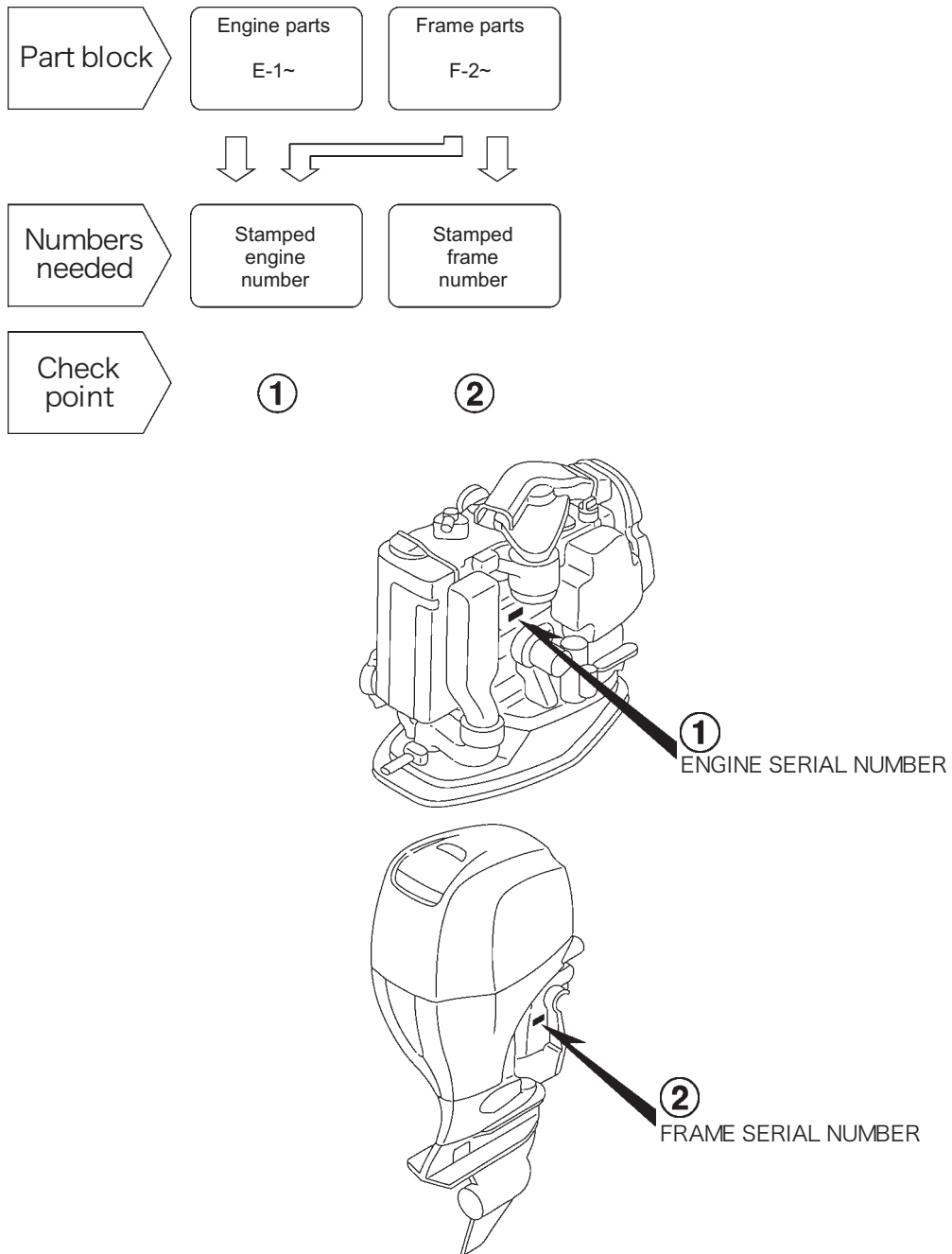

## Models, parts catalogue codes and applicable serial numbers

- Models, parts catalogue codes and applicable serial Nos. given in this parts catalogue can be identified as follows.

Model	Type	Parts catalogue type	Engine		Applicable engine serial No.	Applicable frame serial No.
			Model	Type		
BFT 250A	XD	XD	BF 250A	SE	BEBJJ-1000001~	BBJJ-6000098~
	XU	XU				

## Features of each type

- See the following table for the features of each type. (Items in brackets are optional)

Specifications		Model	BFT 250A	
		Type	XD	XU
Transom height	635 mm		●	●
Trim tab			●	●

# Fuel hose, general purpose hoses and vinyl hose

- The standard part fuel hose, general purpose hose and vinyl hose may be substituted by the coiled bulk part.
- When ordering the standard part fuel hose, general purpose hose and vinyl hose use the bulk part number written in the parts catalog in brackets ( ) underneath the part name.
- When exchanging the hose, cut and use at the specified length as mentioned in the part name. (For the method of cutting the bulk part, and method of filling out orders etc., please refer to the instructions issued with the bulk part.)

## Bulk part number of fuel hose, general purpose hose and vinyl hose.

Example: 95001-75001-50M

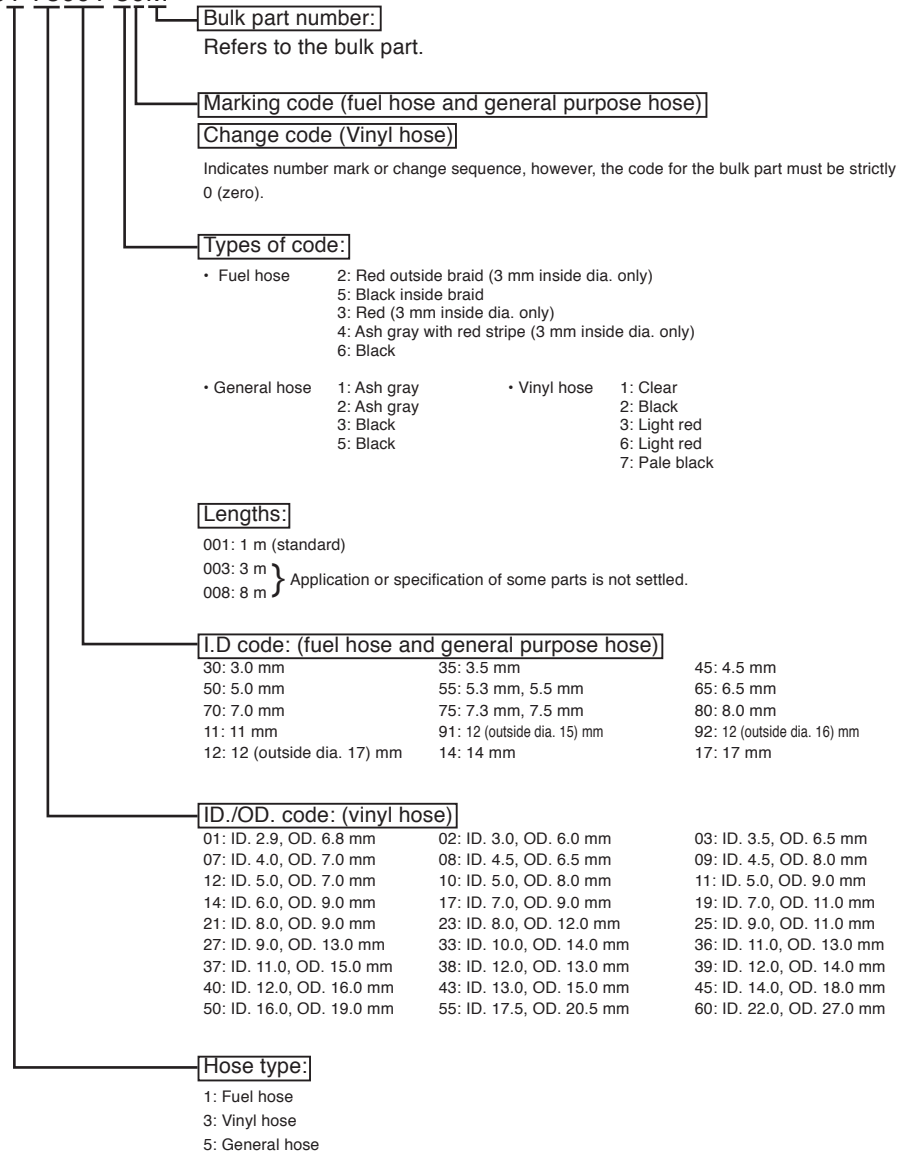

## CAUTION: It is DANGEROUS to confuse the fuel hose with the general purpose hose or vinyl hose.

Never use a general purpose hose or vinyl hose in place of a fuel hose or vice versa.

Always use the correct bulk part in the parts catalogue, according to the service manual or the instructions issued with the bulk part.

E-1 CYLINDER HEAD COVER

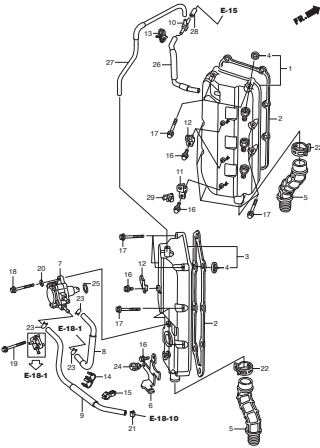

E-3 CYLINDER BLOCK

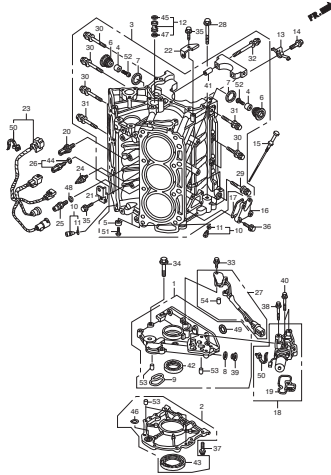

E-3-10 CRANKCASE

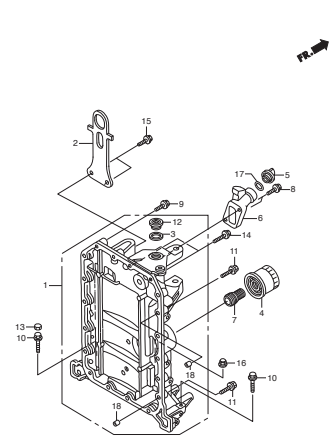

E-4 EXHAUST MANIFOLD/THERMOSTAT

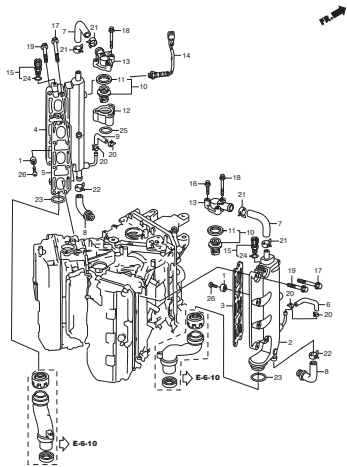

E-5 OIL PUMP/FLYWHEEL

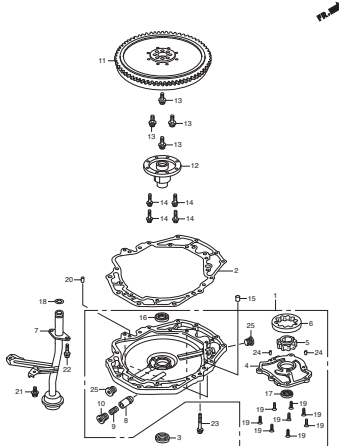

E-6 OIL PAN

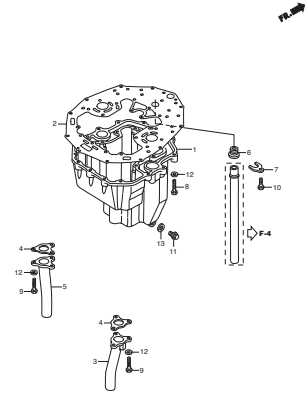

E-6-10 MOUNT CASE

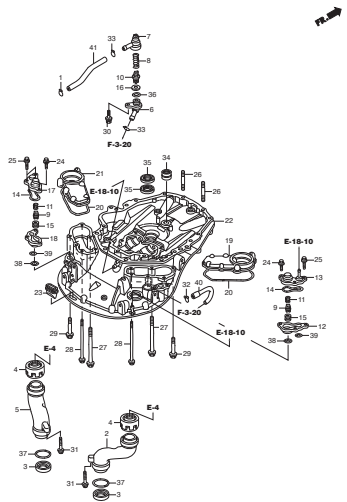

E-6-20 MOUNT CASE BOLT

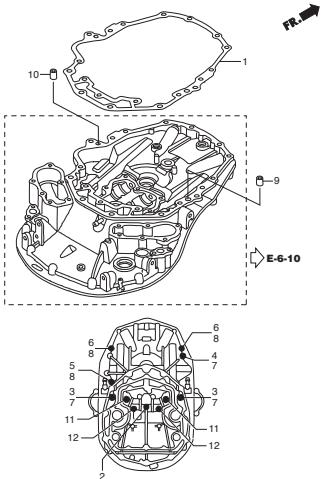

E-7 CRANKSHAFT/PISTON

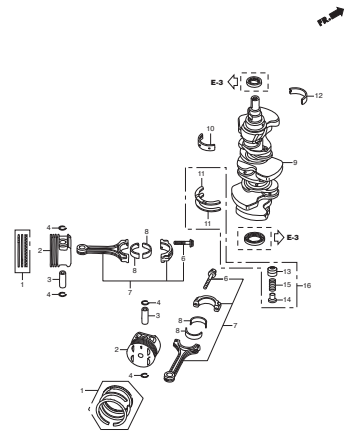

E-9 CYLINDER HEAD

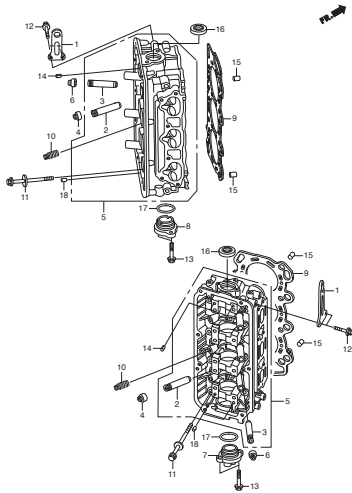

E-9-10 CAMSHAFT/ROCKER ARM

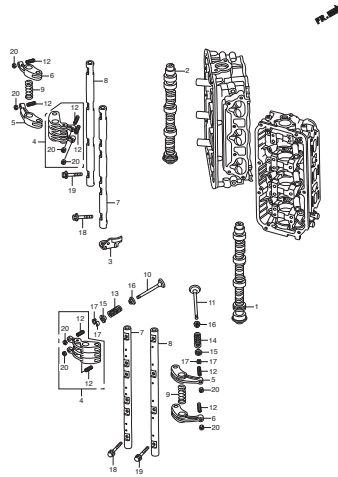

E-13 TIMING BELT

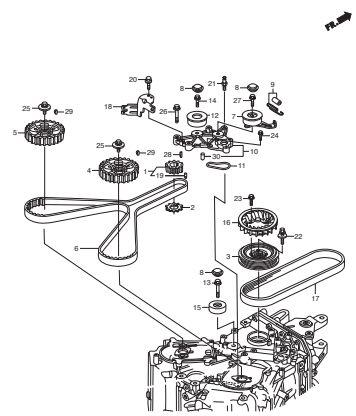

E-13-10 TIMING BELT COVER

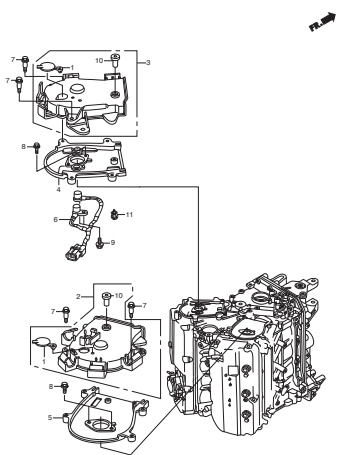

E-14 FUEL PIPE/INJECTOR

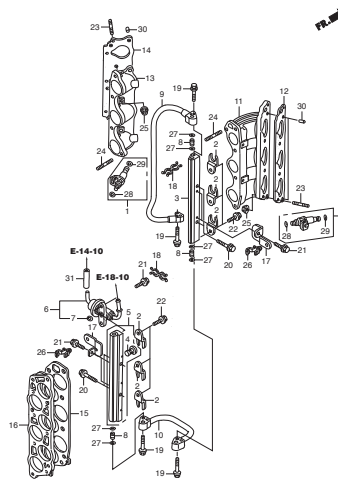

E-14-10 INTAKE MANIFOLD

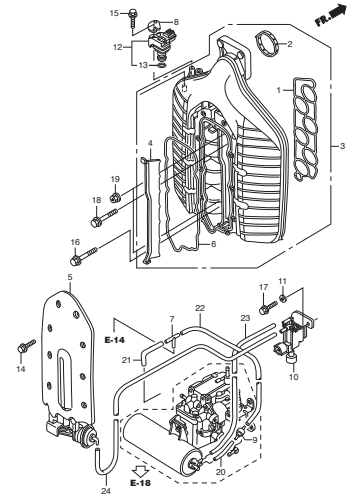

E-15 THROTTLE BODY

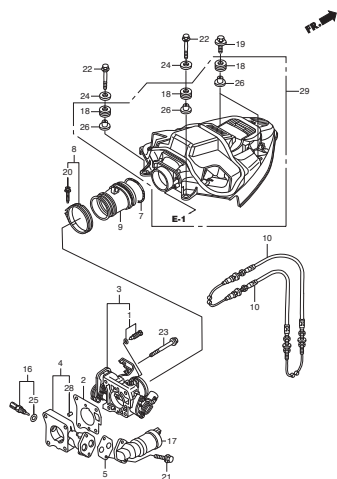

E-18 VAPOR SEPARATOR ASSY

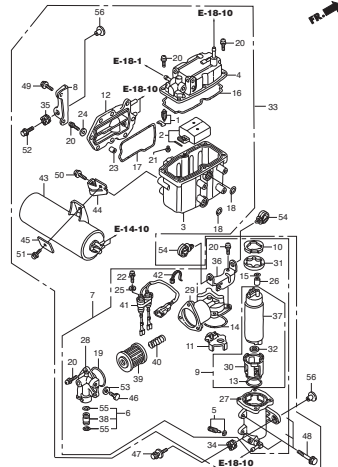

E-18-1 WATER SEPARATOR/FUEL STRAINER

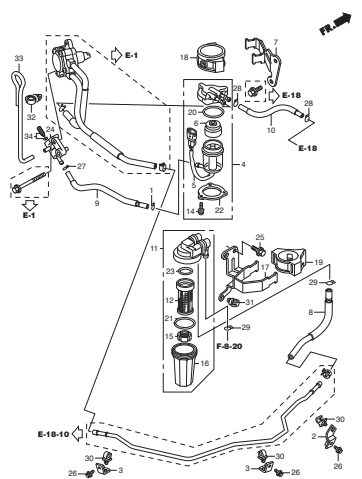

E-18-10 PIPING

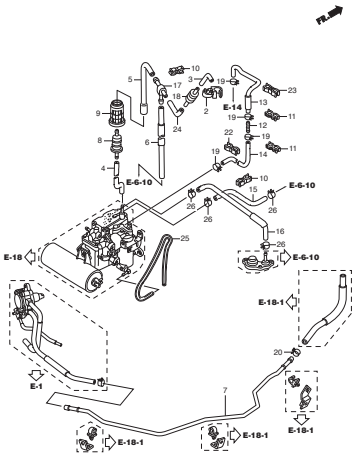

E-19 A.C.GENERATOR

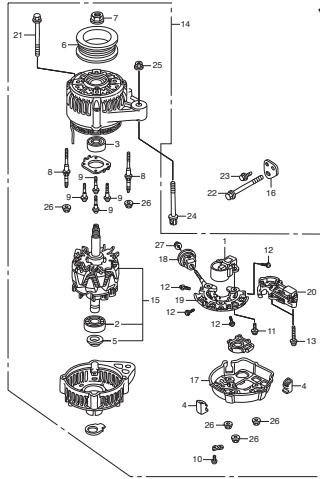

E-20 SPARK PLUG

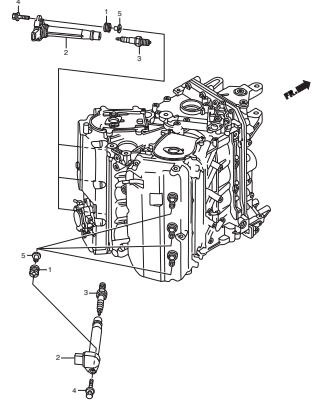

E-20-10 ELECTRONIC CONTROL UNIT

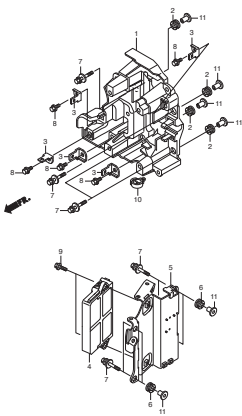

E-21 STARTER MOTOR

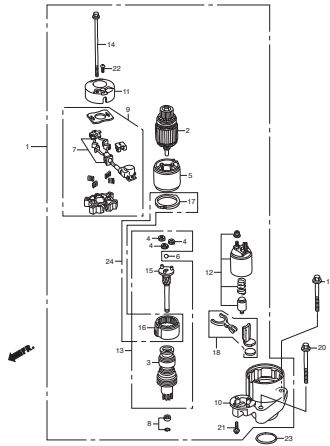

F-2 SHIFT SHAFT

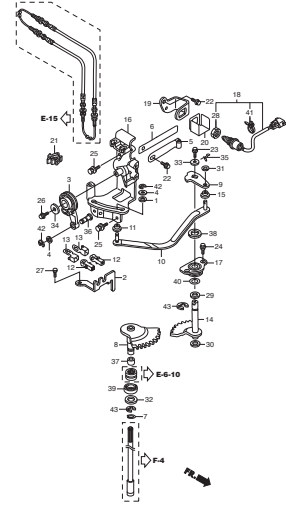

F-3 GEAR CASE

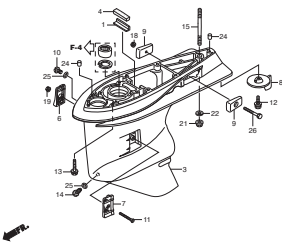

F-3-10 GEAR CASE ASSY

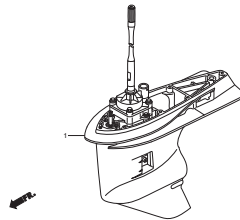

F-3-20 EXTENSION CASE

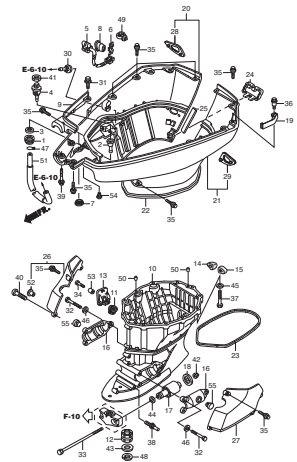



F-4 WATER PUMP/VERTICAL SHAFT

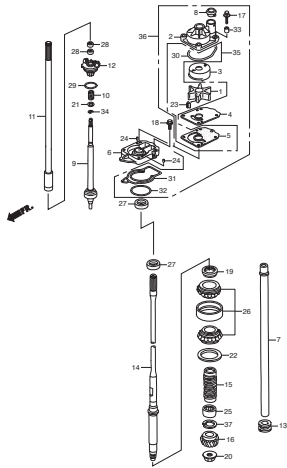

F-5 PROPELLER SHAFT

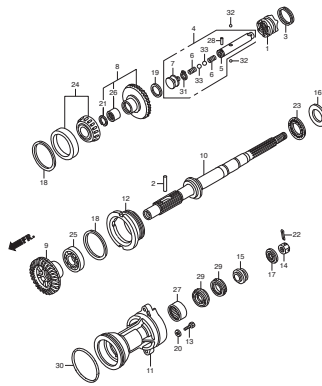

F-6 FUEL TUBE

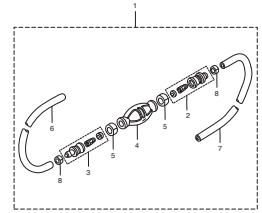

F-7 WIRE HARNESS

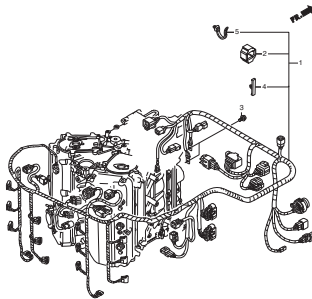

F-7-10 STARTER CABLE

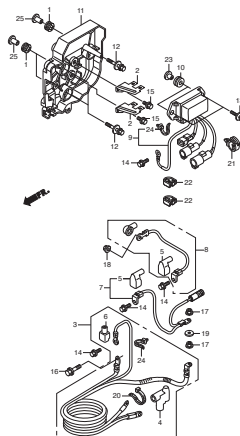

F-7-20 FUSE BOX/RELAY

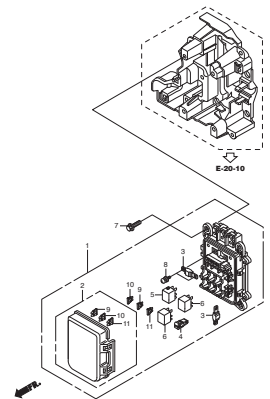

F-8 ENGINE COVER

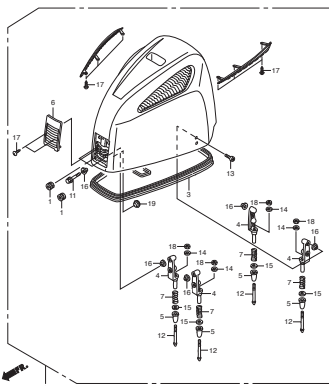

F-8-10 FR.COVER BRACKET/FR.LOCK SHAFT

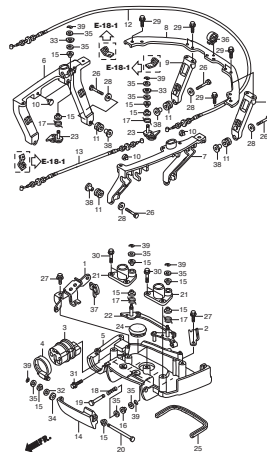

F-8-20 FUEL TUBE (2)

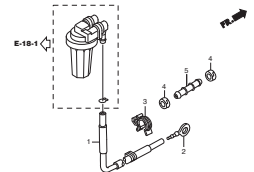

**F-10 STERN BRACKET/SWIVEL CASE**

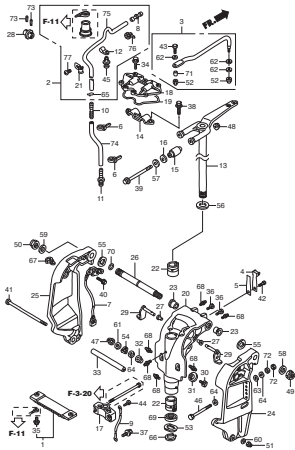

**F-11 POWER TRIM-TILT**

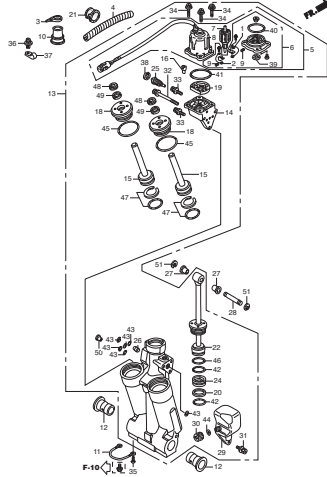

**F-12 LABEL**

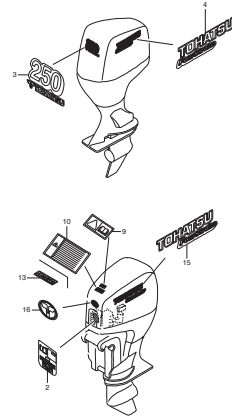

**F-13 TOOL**

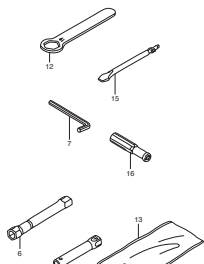

**FOP-1 REMOTE CONTROL (TOP MOUNT SINGLE TYPE) (RIGHT)**

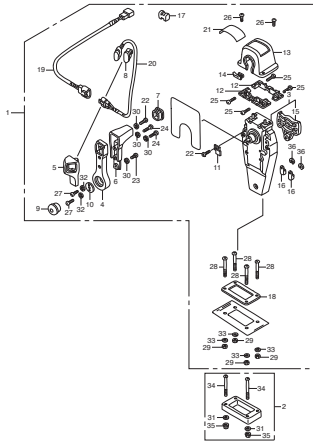

**FOP-1-2 REMOTE CONTROL (TOP MOUNT DUAL TYPE) (RIGHT)**

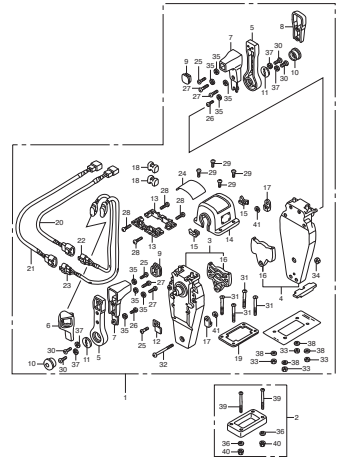

**FOP-1-4 REMOTE CONTROL (FLUSH MOUNT TYPE) (RIGHT)**

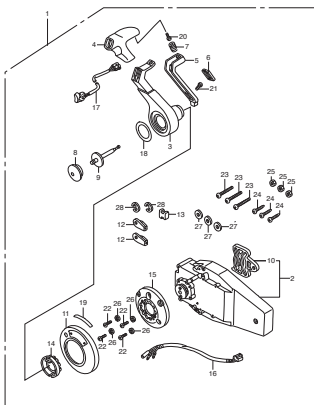

**FOP-1-6 REMOTE CONTROL**

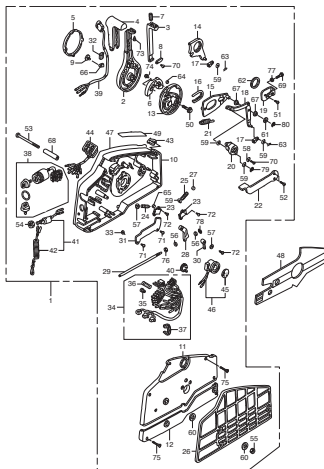

**FOP-3 METER**

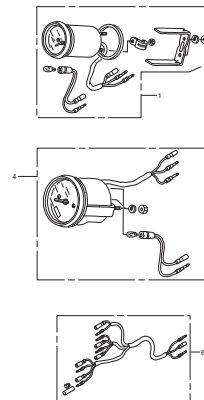

FOP-5 BOLT KIT

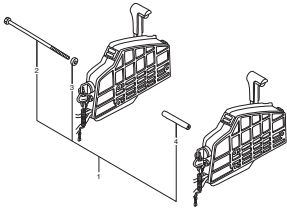

FOP-6 SWITCH PANEL KIT

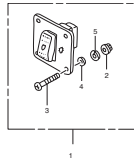

FOP-7 CONTROL PANEL (1)

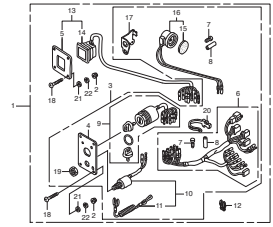

FOP-7-1 CONTROL PANEL (2)

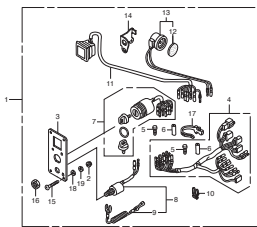

FOP-8 RIGGING HOSE KIT

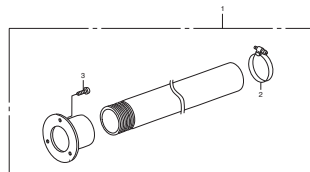

FOP-9 TRIM ADJUST PLATE SET

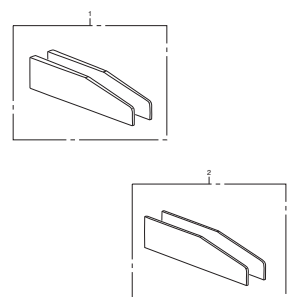

FOP-10 INTERFACE CABLE KIT

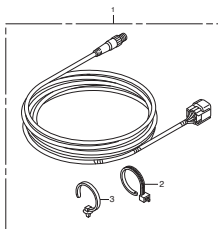

FOP-12 PROPELLER

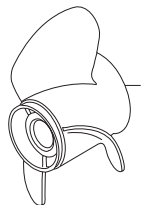

FOP-13 PANEL INTERFACE CABLE SET

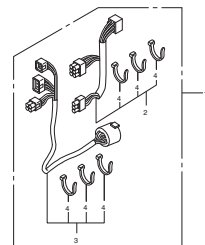

FOP-14 GEAR CASE KIT

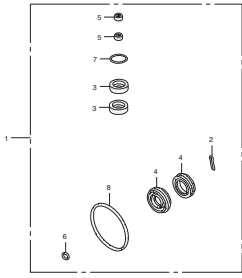





Ref.No.	Part No.	Description	Q' ty	Remarks	
			BF250A		
E-1	1	HZY3-12310-405ZA	COVER, R. CYLINDER HEAD	1	*NH8* DARK GRAY
E-1	2	HZY3-12312-000	PACKING, HEAD COVER	2	
E-1	3	HZY3-12320-405ZA	COVER, L. CYLINDER HEAD	1	*NH8* DARK GRAY
E-1	4	HP08-12342-004	SEAL, SPARK PLUG TUBE(NOK)	6	
E-1	5	HZY3-15425-010	TUBE, OIL	2	
E-1	6	HZY3-16203-000	BRACKET, SOLENOID VALVE	1	
E-1	7	HZX2-16700-003	PUMP ASSY., FUEL	1	
E-1	8	HZX2-16870-000	TUBE COMP. C, FUEL	1	
E-1	9	HZY3-16895-000	TUBE COMP. G, FUEL	1	
E-1	10	HMT2-17193-000	T-JOINT	1	
E-1	11	HZW9-32114-730	BRACKET, CLIP B	1	
E-1	12	HZY3-32129-000	BRACKET C, HARNESS CLIP	3	
E-1	13	HHE0-50310-003	CLIP A, WIRE	1	
E-1	14	HSE0-53740-953	CLIP, SENSOR HOSE	1	
E-1	15	HSD9-54316-013	CLIP, SHIFT WIRE	1	
E-1	16	HZW9-90011-000	BOLT, FLANGE, 6X14(CT200)	5	
E-1	17	HZW9-90019-000	BOLT, FLANGE, 6X35	16	
E-1	18	HZY3-90036-000	BOLT, FLANGE, 8X32	1	
E-1	19	HZW4-90126-000	BOLT, FLANGE, 8X45	1	
E-1	20	HZY3-90406-000	WASHER, PLAIN, 8MM	1	
E-1	21	HZW5-90602-030	CLAMP, TUBE(D12)	1	
E-1	22	HZY3-90602-020	CLAMP, TUBE(D32.5)	2	
E-1	23	HZV0-90604-000	CLIP, TUBE(B12)	3	
E-1	24	HZB7-90691-003	CLIP, HARNESS	1	
E-1	25	HKT7-91305-003	O-RING, 37X2.4(ARAI)	1	
E-1	26	HZY3-91401-A00	TUBE COMP. A, BREATHER	1	
E-1	27	HZY3-91402-020	TUBE B, BREATHER	1	
E-1	28	HZY3-91403-000	TUBE C, BREATHER	1	
E-1	29	HSK7-91566-003	CLIP D, WASHER TUBE	1	

FR. 

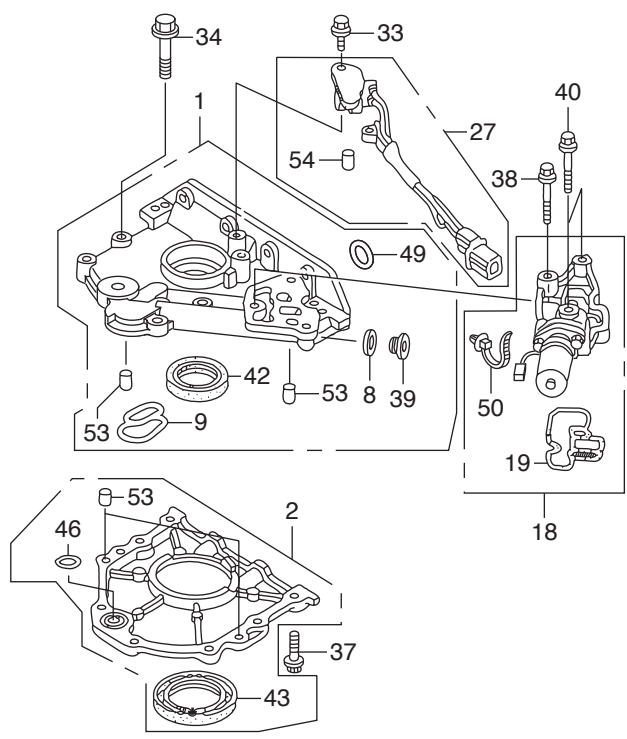
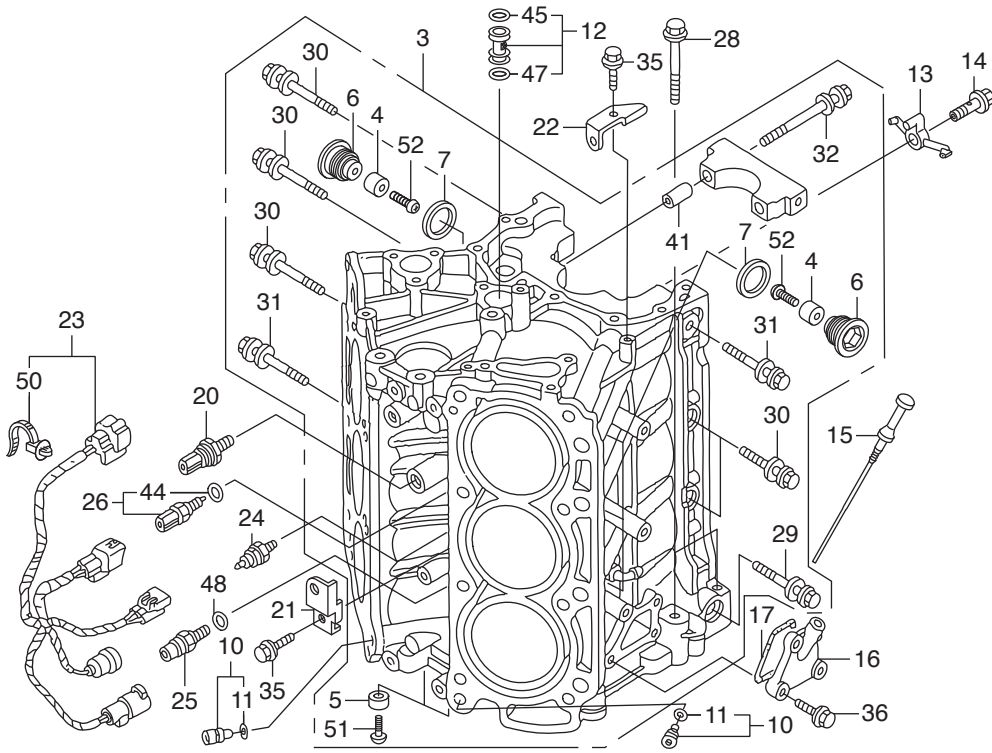



Ref.No.	Part No.	Description	Q' ty	Remarks	
			BF250A		
E-3	1	HZY3-11200-010ZA	COVER ASSY., CRANKCASE UPPER	1	*NH8* DARK GRAY
E-3	2	HZY3-11300-C00	CASE ASSY., OIL SEAL	1	
E-3	3	HZX2-12000-405ZA	BLOCK ASSY., CYLINDER	1	*NH8* DARK GRAY
E-3	4	HZV4-12155-A00	METAL, ANODE	6	
E-3	5	HZY3-12155-000	METAL, ANODE	2	
E-3	6	HZY3-12164-000	BOLT, SEALING, 22MM	6	
E-3	7	HZY3-12171-305	WASHER, SEALING, 22MM	6	
E-3	8	HZV5-12214-000	WASHER, SEALING(22MM)	1	
E-3	9	HP8A-15115-A01	PACKING, OIL HOLE	1	
E-3	10	HP8A-15140-A00	ORIFICE ASSY., OIL CONTROL	2	
E-3	11	HP8A-15142-A00	O-RING, 8.8X2.4	2	
E-3	12	HP8A-15150-A00	JOINT ASSY., OIL PIPE	1	
E-3	13	HR70-15280-A00	BODY, OIL JET	3	
E-3	14	HRJA-15290-000	BOLT COMP., OIL JET	3	
E-3	15	HZX2-15655-000	GAUGE COMP., OIL LEVEL	1	
E-3	16	HZY3-15656-000	COVER, OIL LEVEL GAUGE	1	
E-3	17	HZY3-15657-000	PACKING, OIL LEVEL GAUGE	1	
E-3	18	HZY3-15810-003ZA	VALVE ASSY., SPOOL	1	*NH8* DARK GRAY
E-3	19	HZY3-15825-003	FILTER ASSY., SPOOL VALVE	1	
E-3	20	HRNA-30530-A01	SENSOR COMP., KNOCK	1	
E-3	21	HZW9-32114-730	BRACKET, CLIP B	1	
E-3	22	HZY3-32116-000	BRACKET B, HARNESS CLIP	1	
E-3	23	HZY3-32193-C00	CORD, SWITCH	1	
E-3	24	HZW9-35490-003	SWITCH ASSY., OIL PRESSURE	1	
E-3	25	HZY3-35490-004	SWITCH ASSY., OIL PRESSURE	1	
E-3	26	HZY3-35673-003	SENSOR ASSY., WATER	1	TEMPERATURE
E-3	27	HZY3-35700-003	SENSOR ASSY., CRANK	1	
E-3	28	HZY3-90001-000	BOLT, FLANGE, 12X95	2	
E-3	29	HZY3-90006-003	BOLT-WASHER, 10X109	1	

FR. 

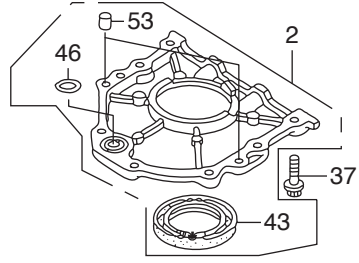
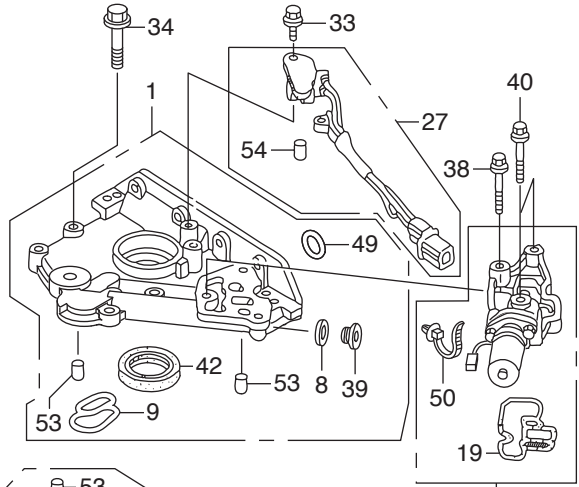
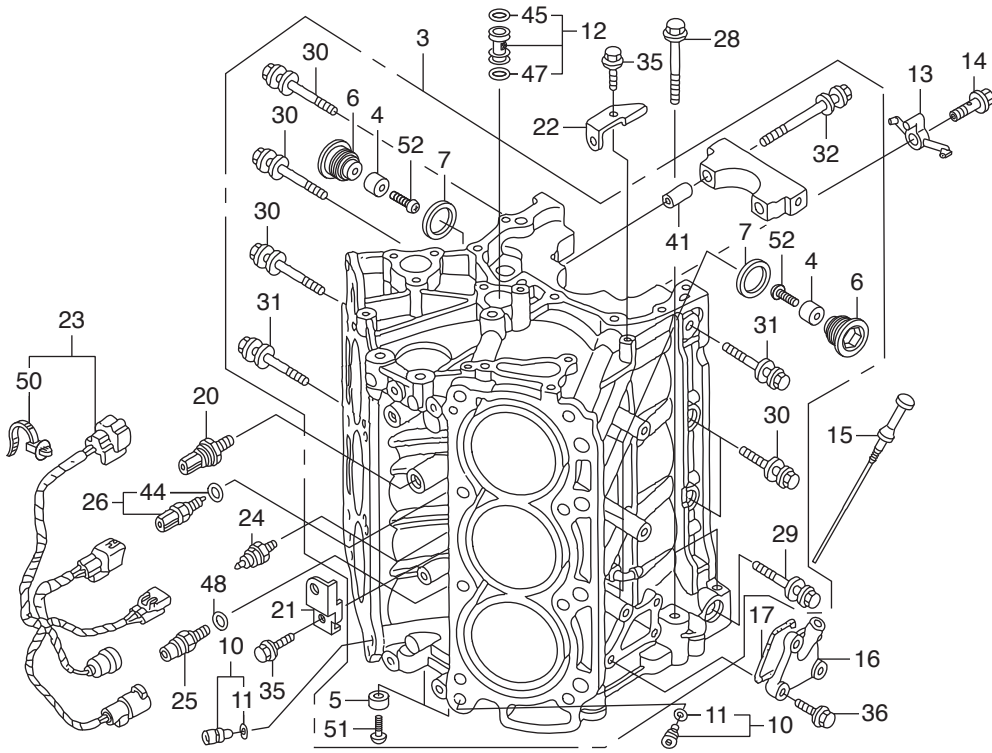

Ref.No.	Part No.	Description	Q' ty	Remarks	
			BF250A		
E-3	30	HZY3-90008-003	BOLT-WASHER, 10X60	5	
E-3	31	HZY3-90009-003	BOLT-WASHER, 10X80	2	
E-3	32	HRCA-90014-A01	BOLT-WASHER, 11X105	8	
E-3	33	HZY3-90017-000	BOLT, FLANGE, 6X16	1	
E-3	34	HZW9-90019-000	BOLT, FLANGE, 6X35	7	
E-3	35	HZY3-90021-000	BOLT, FLANGE, 6X14	2	
E-3	36	HZY3-90028-000	BOLT, FLANGE, 6X18	4	
E-3	37	HZY3-90030-000	BOLT, FLANGE, 6X22	8	
E-3	38	HZY3-90038-000	BOLT, FLANGE, 8X75	1	
E-3	39	HZV5-90081-010	BOLT, SEALING, 22MM	1	
E-3	40	HZW4-90156-000	BOLT, FLANGE, 8X50	2	
E-3	41	HPH7-90715-000	DOWEL PIN, 13X37	8	
E-3	42	HZY3-91212-003	OIL SEAL, 41X66X8	1	
E-3	43	HPNA-91214-014	OIL SEAL, 80X98X10(ARAI)	1	
E-3	44	HPNA-91307-003	O-RING, 9.5X1.9	1	
E-3	45	HP8A-91308-A01	O-RING, 18.3X3.5	1	
E-3	46	HPK1-91308-003	O-RING, 26.2X2.4(NOK)	1	
E-3	47	HP8A-91309-A01	O-RING, 16.3X3.5	1	
E-3	48	HPR3-91319-003	O-RING, 13X1.5(ARAI)	1	
E-3	49	HP0X-91321-003	O-RING, 25X2.4(NOK)	1	
E-3	50	HS0A-91541-003	CLIP, HARNESS BAND(BLACK)	2	(145MM)
E-3	51	HCO-93500-05016-4J	SCREW, PAN, 5X16	2	
E-3	52	HCO-93500-05020-4J	SCREW, PAN, 5X20	6	
E-3	53	HCO-94301-06100	DOWEL PIN, 6X10	4	
E-3	54	HCO-94303-05080	DOWEL PIN, 5X8	1	

FR. 

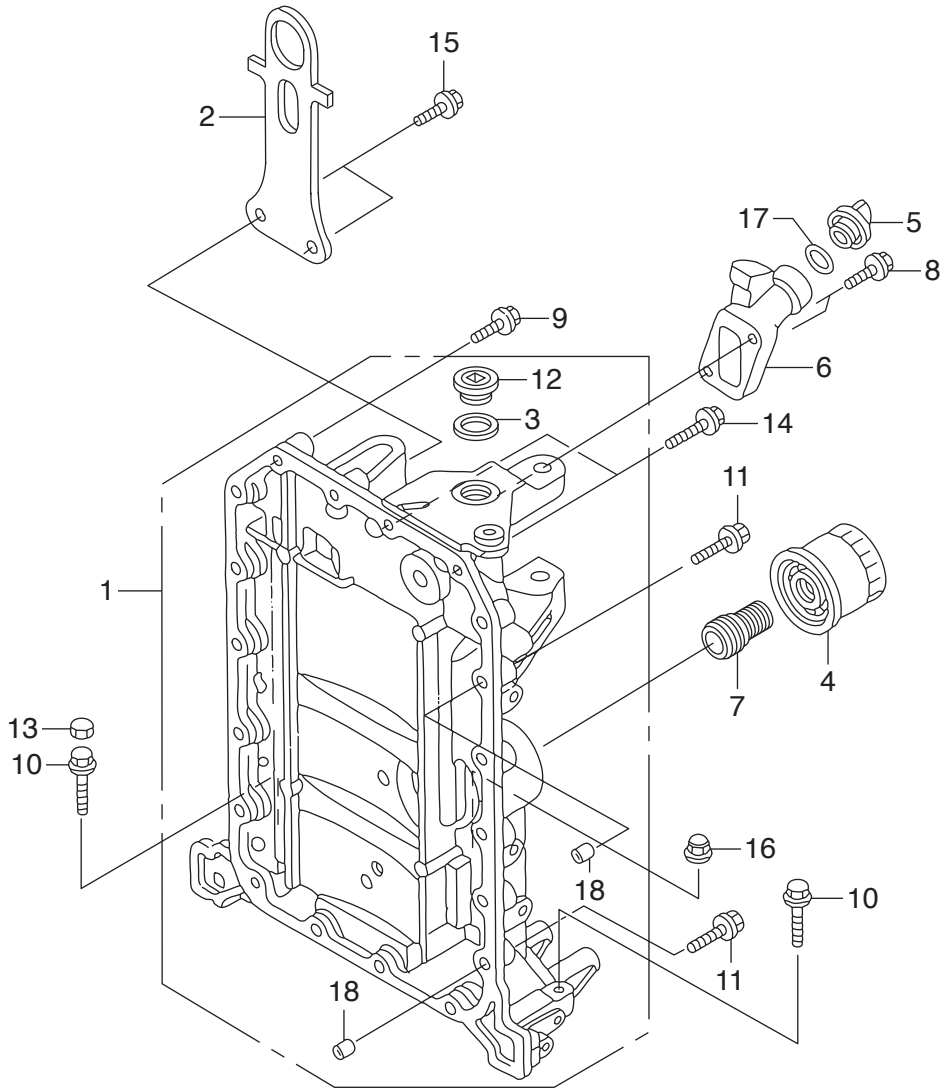



FR. →

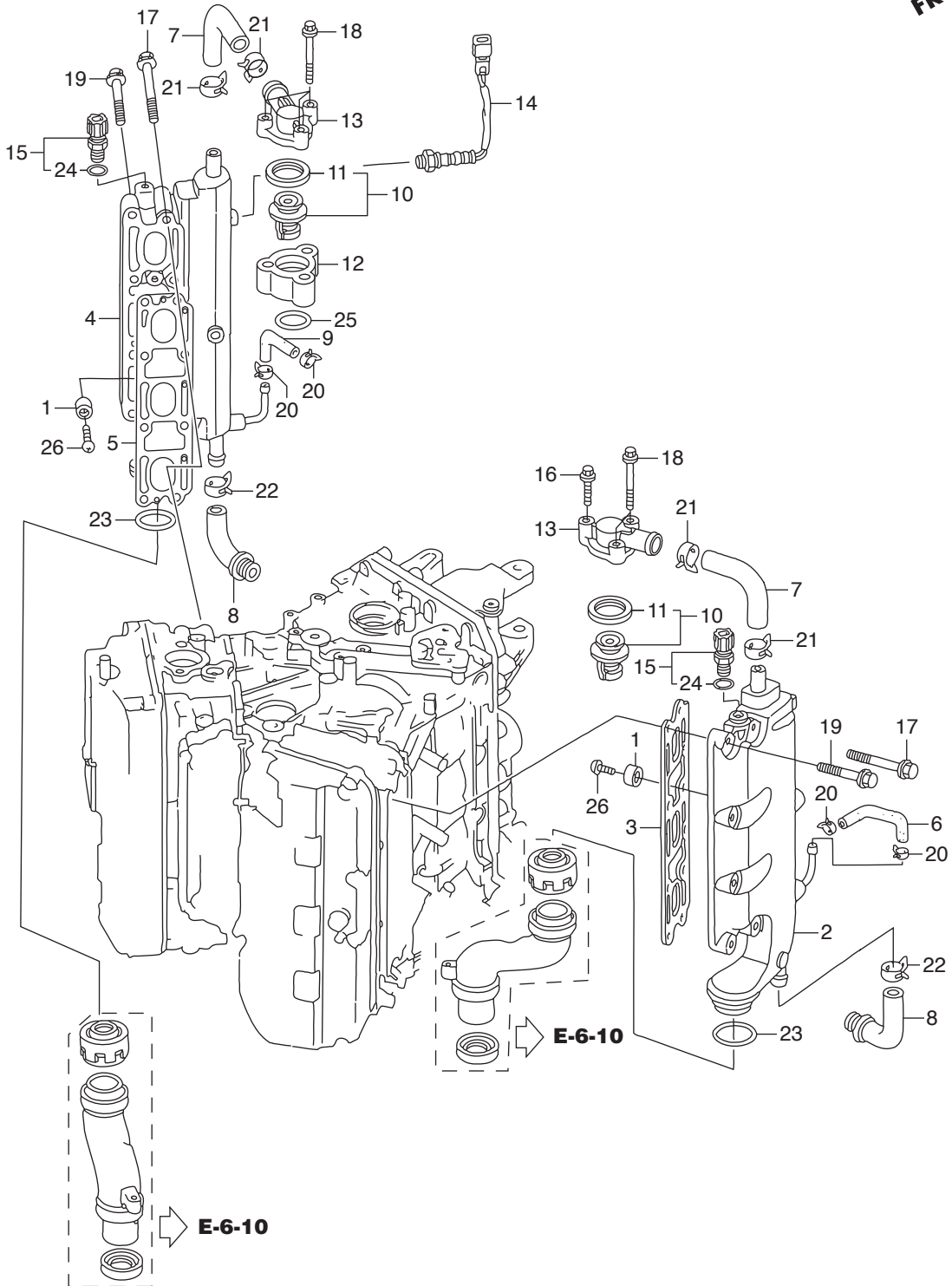

Ref.No.	Part No.	Description	Q' ty	Remarks	
			BF250A		
E-4	1	HZV5-12155-000	METAL, ANODE	4	
E-4	2	HZY3-18110-010ZA	MANIFOLD COMP., R. EX.	1	*NH8* DARK GRAY
E-4	3	HZY3-18115-003	GASKET, R. EX. MANIFOLD	1	
E-4	4	HZY3-18120-C01ZA	MANIFOLD COMP., L. EX.	1	*NH8* DARK GRAY
E-4	5	HZY3-18125-003	GASKET, L. EX. MANIFOLD	1	
E-4	6	HZY3-19255-000	TUBE, R. WATER RETURN	1	
E-4	7	HZY3-19256-010	TUBE, WATER RELIEF	2	
E-4	8	HZY3-19257-000	TUBE, WATER	2	
E-4	9	HZY3-19261-000	TUBE, L. WATER RETURN	1	
E-4	10	HZX2-19300-003	THERMOSTAT ASSY.	2	
E-4	11	HZX2-19303-003	RUBBER, RING	2	
E-4	12	HZX2-19313-000ZA	SPACER, THERMOSTAT COVER	1	*NH8* DARK GRAY
E-4	13	HZX2-19315-000ZA	COVER, THERMOSTAT	2	*NH8* DARK GRAY
E-4	14	HZY3-35655-C01	SENSOR, OXYGEN	1	
E-4	15	HZY3-35673-003	SENSOR ASSY., WATER	2	TEMPERATURE
E-4	16	HZW9-90019-000	BOLT, FLANGE, 6X35	1	
E-4	17	HZY3-90027-000	BOLT, FLANGE, 8X60	8	
E-4	18	HZY3-90034-000	BOLT, FLANGE, 6X60	5	
E-4	19	HZW4-90155-000	BOLT, FLANGE, 8X40	8	
E-4	20	HZY3-90601-030	CLAMP, TUBE(D10.5)	4	
E-4	21	HZY3-90603-020	CLAMP, TUBE(D29)	4	
E-4	22	HZY3-90604-020	CLAMP, TUBE(D21)	2	
E-4	23	HZY3-91301-003	O-RING, 66.4X3.1	2	
E-4	24	HPNA-91307-003	O-RING, 9.5X1.9	2	
E-4	25	HSD4-91356-952	O-RING, 31.5X2.4(ARAI)	1	
E-4	26	HCO-93500-06018-4J	SCREW, PAN, 6X18	4	

FR. 

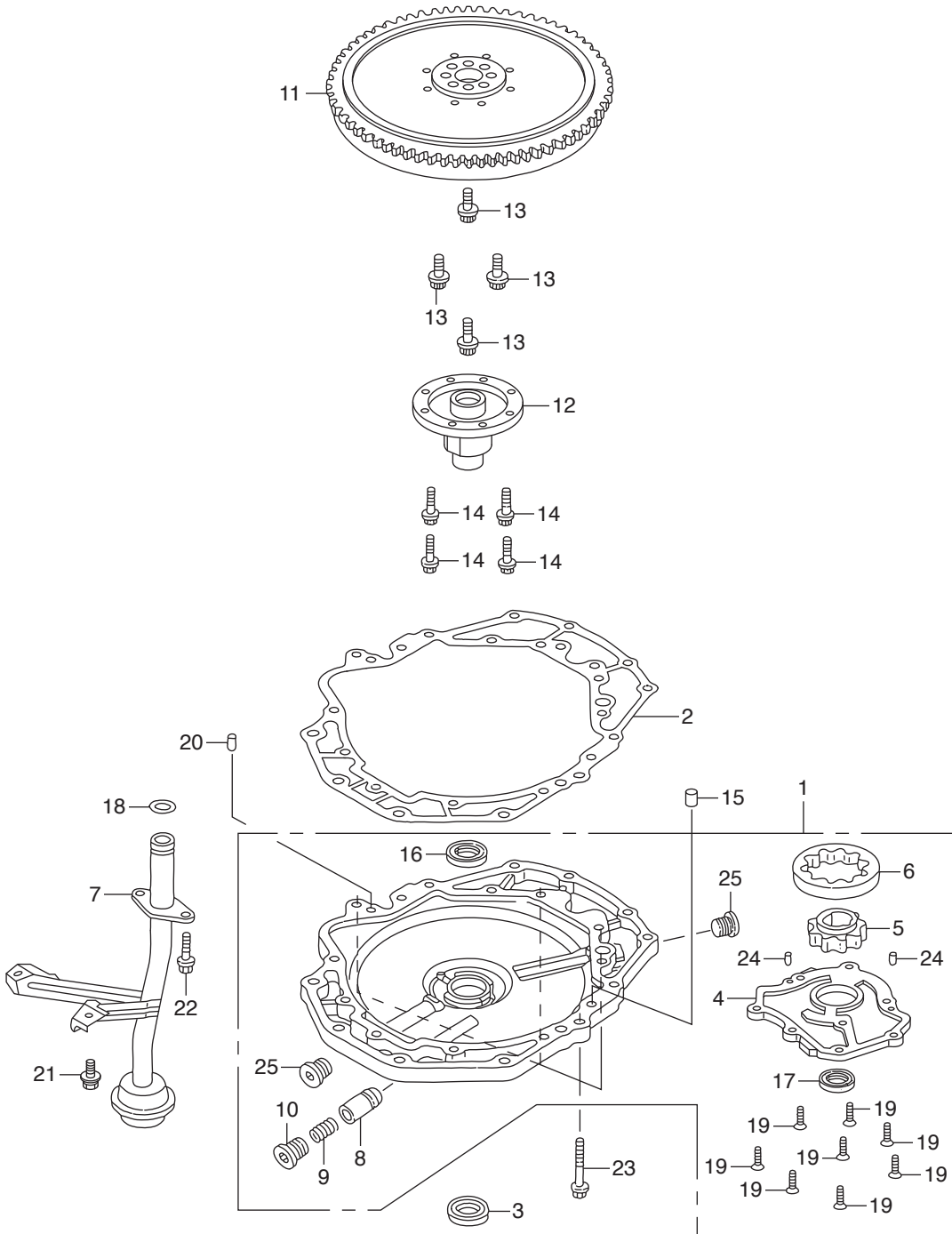



Ref.No.	Part No.	Description	Q' ty	Remarks	
			BF250A		
E-5	1	HZY3-15100-000ZA	PUMP ASSY., OIL	1	*NH8* DARK GRAY
E-5	2	HZY3-15112-013	PACKING, OIL PUMP BODY	1	
E-5	3	HZY3-15113-000	RUBBER, OIL PUMP	1	
E-5	4	HZY3-15121-000	COVER, OIL PUMP	1	
E-5	5	HZY3-15131-405	ROTOR, OIL PUMP INNER	1	
E-5	6	HZY3-15132-405	ROTOR, OIL PUMP OUTER	1	
E-5	7	HZY3-15220-020	STRAINER COMP., OIL	1	
E-5	8	HPE0-15231-000	VALVE, RELIEF	1	
E-5	9	HPG6-15232-000	SPRING, RELIEF VALVE	1	
E-5	10	HPC6-15233-000	BOLT, SEALING, 18MM	1	
E-5	11	HZX2-31110-000ZA	FLYWHEEL COMP.	1	*TBLACK* BLACK
E-5	12	HZY3-31116-000	BOSS, FLYWHEEL	1	
E-5	13	HZX2-90001-000	BOLT, 12MM	8	
E-5	14	HZW5-90002-013	BOLT, SPECIAL, 8MM	8	
E-5	15	HPW5-90701-000	DOWEL PIN, 14X15	1	
E-5	16	HZW5-91201-003	OIL SEAL, 46X60X9	1	
E-5	17	HP01-91212-003	OIL SEAL, 31X46X7(NOK)	1	
E-5	18	HPC6-91324-000	O-RING, 20.6X2.6	1	
E-5	19	HCO-93600-06016-0A	SCREW, FLAT, 6X16	8	
E-5	20	HCO-94302-10160	PIN B, DOWEL, 10X16	1	
E-5	21	HCO-95701-06014-09	BOLT, FLANGE, 6X14	2	
E-5	22	HCO-95701-06018-09	BOLT, FLANGE, 6X18	2	
E-5	23	HCO-95701-08030-09	BOLT, FLANGE, 8X30	4	
E-5	24	HCO-96220-50080	ROLLER, 5X8	2	
E-5	25	HZV5-90081-010	BOLT, SEALING, 22MM	2	

FR. 

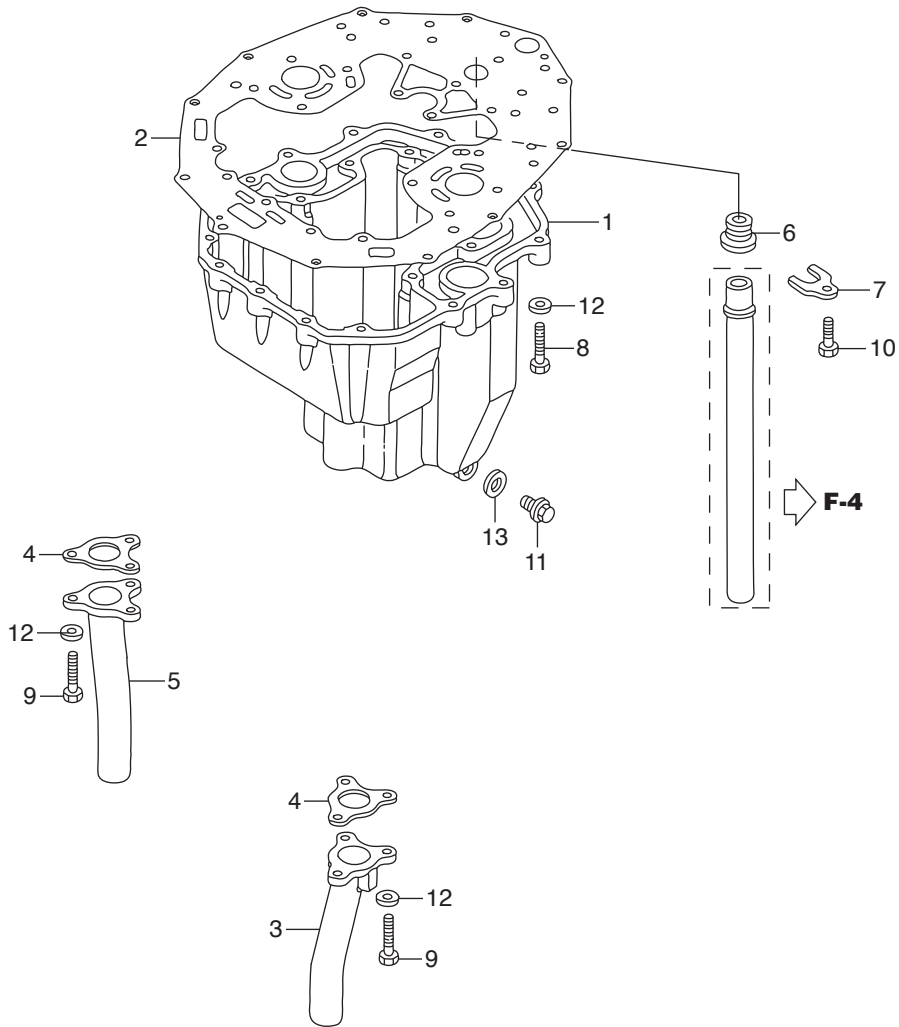



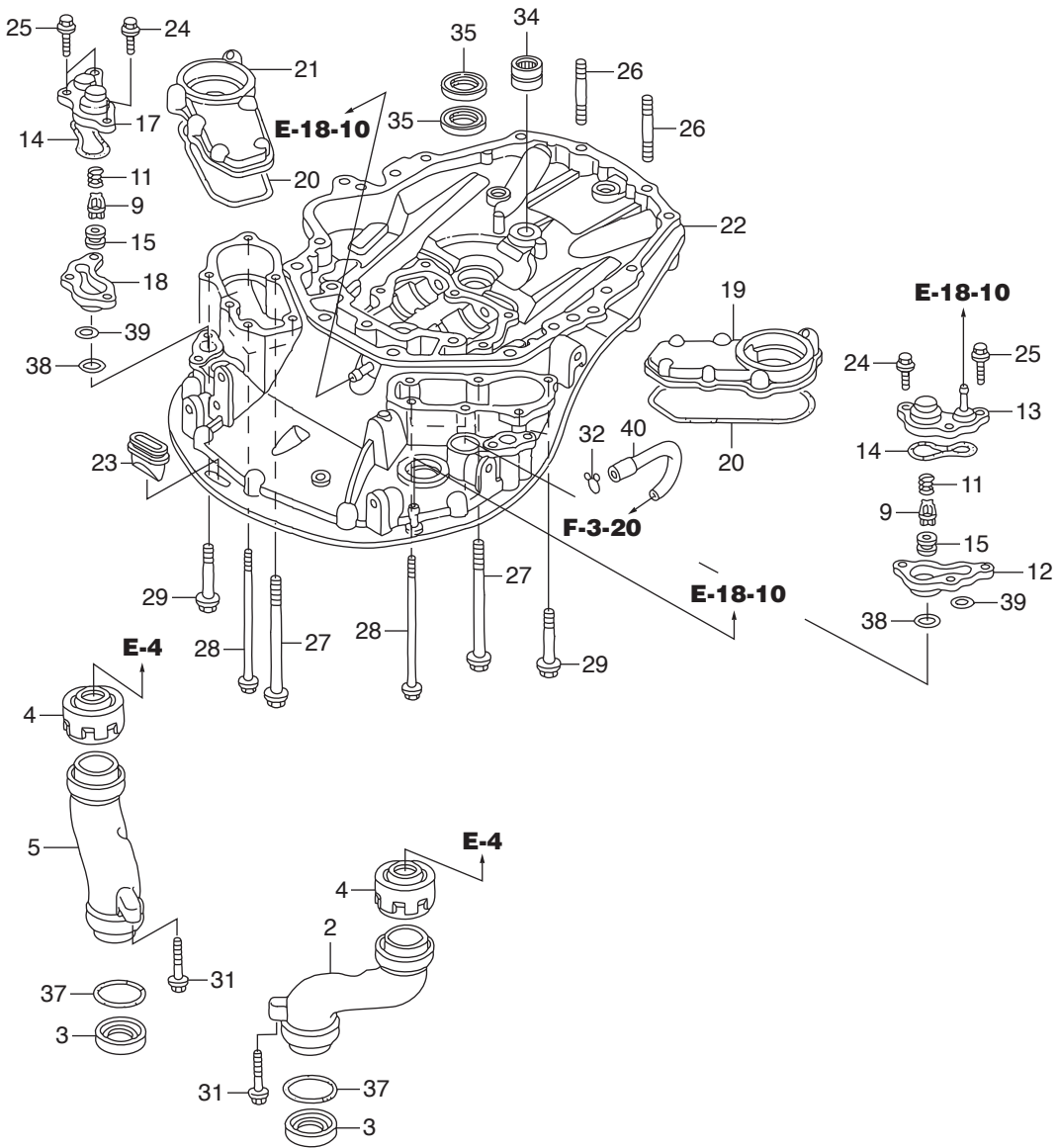
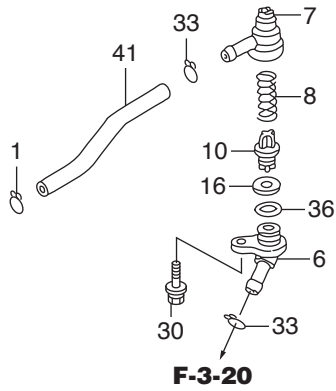

Ref.No.	Part No.	Description	Q' ty	Remarks	
			BF250A		
E-6-10	1	HGHB-16163-610	CLIP, TUBE	1	
E-6-10	2	HZY3-18141-A00ZA	GUIDE, R. EX.	1	*TGRAY* GRAY
E-6-10	3	HZY3-18148-003	SEAL, EXHAUST GUIDE	2	
E-6-10	4	HZY3-18149-A01	SEAL B, EX. GUIDE	2	
E-6-10	5	HZY3-18151-A00ZA	GUIDE, L. EX.	1	*TGRAY* GRAY
E-6-10	6	HZY3-19277-000ZA	COVER, FLUSH VALVE	1	*NH8* DARK GRAY
E-6-10	7	HZY3-19278-000	CASE, FLUSH VALVE	1	
E-6-10	8	HZW9-19279-000	SPRING, FLUSH VALVE	1	
E-6-10	9	HZW5-19291-000	VALVE, RELIEF	2	
E-6-10	10	HZW9-19291-000	VALVE, FLASH	1	
E-6-10	11	HZW5-19292-000	SPRING, RELIEF VALVE	2	
E-6-10	12	HZY3-19294-000ZB	SPACER, R. RELIEF VALVE	1	*TGRAY* GRAY
E-6-10	13	HZY3-19295-000	COVER, R. RELIEF VALVE	1	
E-6-10	14	HZY3-19296-000	PACKING, RELIEF VALVE COVER	2	
E-6-10	15	HZW5-19297-000	PACKING, RELIEF VALVE	2	
E-6-10	16	HZW9-19297-000	PACKING, FLASH VALVE	1	
E-6-10	17	HZY3-19297-000	COVER, L. RELIEF VALVE	1	
E-6-10	18	HZY3-19298-000ZB	SPACER, L. RELIEF VALVE	1	*TGRAY* GRAY
E-6-10	19	HZY3-19361-000	COVER, R. WATER JACKET	1	
E-6-10	20	HZY3-19362-000	PACKING, WATER JACKET COVER	2	
E-6-10	21	HZY3-19366-000	COVER, L. WATER JACKET	1	
E-6-10	22	HZY3-23170-030ZA	CASE COMP., MOUNT	1	*NH8* DARK GRAY
E-6-10	23	HZY3-23173-010	RUBBER, MOUNT CASE SEAL	1	
E-6-10	24	HZY3-90030-000	BOLT, FLANGE, 6X22	2	
E-6-10	25	HZY3-90031-000	BOLT, FLANGE, 6X32	4	
E-6-10	26	HZY3-90045-000	BOLT, STUD, 10X45	2	
E-6-10	27	HZY3-90046-000	BOLT, FLANGE, 8X100	2	
E-6-10	28	HZY3-90047-000	BOLT, WASHER, 6X121	6	
E-6-10	29	HZY3-90049-000	BOLT, FLANGE, 8X30	4	

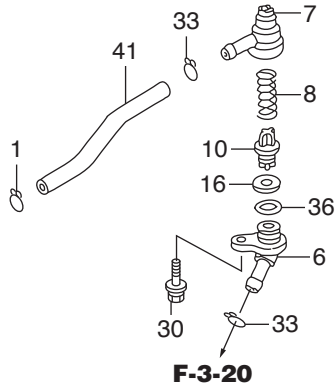

**F-3-20**

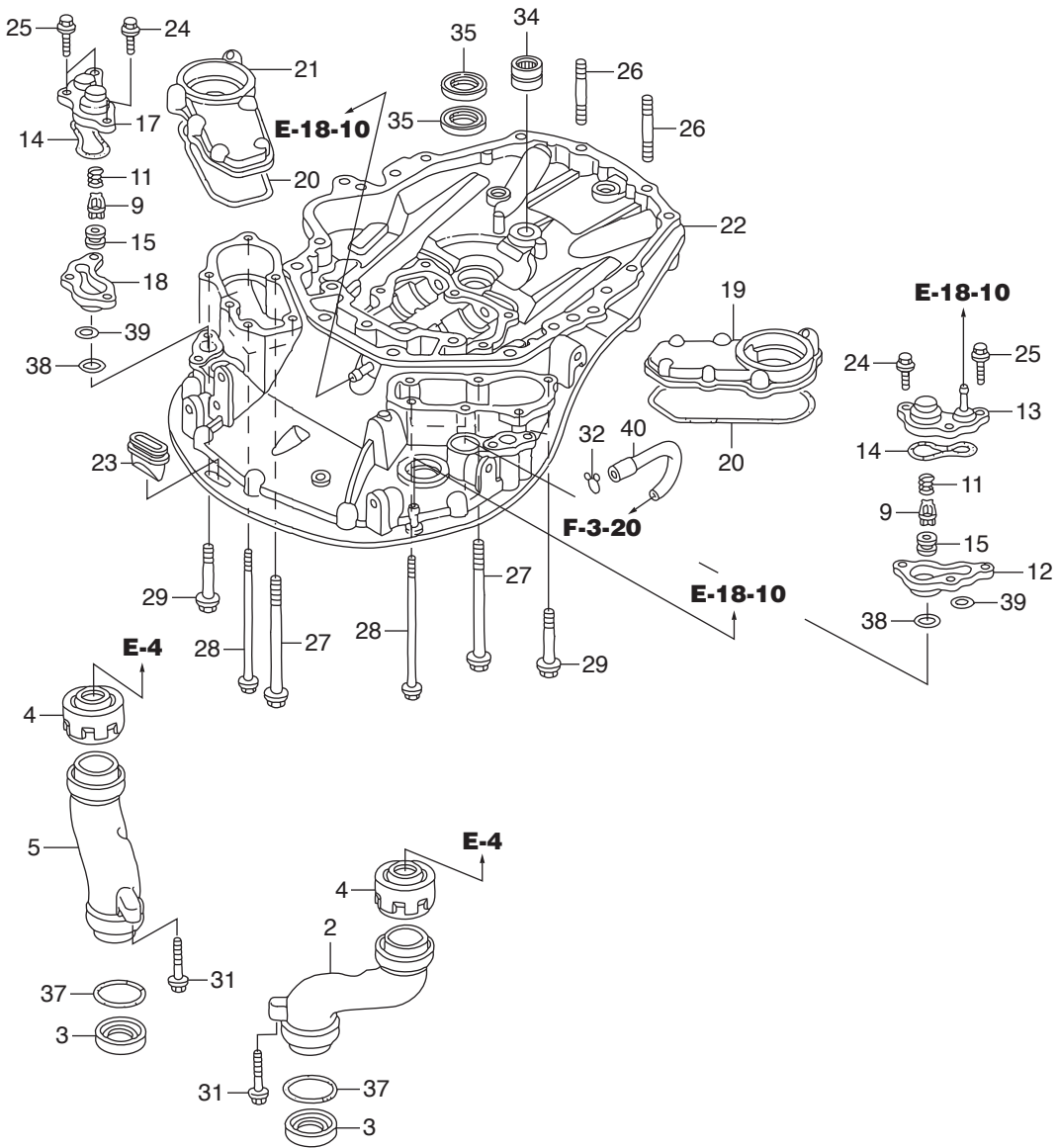

Ref.No.	Part No.	Description	Q' ty	Remarks	
			BF250A		
E-6-10	30	HZY3-90059-000	BOLT-WASHER, 6X29	1	
E-6-10	31	HHW1-90207-671	BOLT, FLANGE, 6X40	2	
E-6-10	32	HZV4-90603-000	CLIP, TUBE(B10)	1	
E-6-10	33	HZV4-90605-000	CLIP, TUBE(B12.5)	2	
E-6-10	34	HZY3-91001-003	BEARING, NEEDLE, 20X28X13	1	(SOLID)
E-6-10	35	HZW5-91202-003	SEAL, WATER, 22X35X7	2	
E-6-10	36	H800-91303-000	O-RING, 16MM	1	
E-6-10	37	HZY3-91304-000	O-RING, 49.4X3.1	2	
E-6-10	38	HZY3-91305-003	O-RING, 33.5X2	2	
E-6-10	39	HZY3-91306-003	O-RING, 23.5X2	2	
E-6-10	40	HZY3-91404-000	TUBE, WATER CHECK	1	
E-6-10	41	HZY3-91405-000	TUBE, FLUSH VALVE	1	

**FR.** 

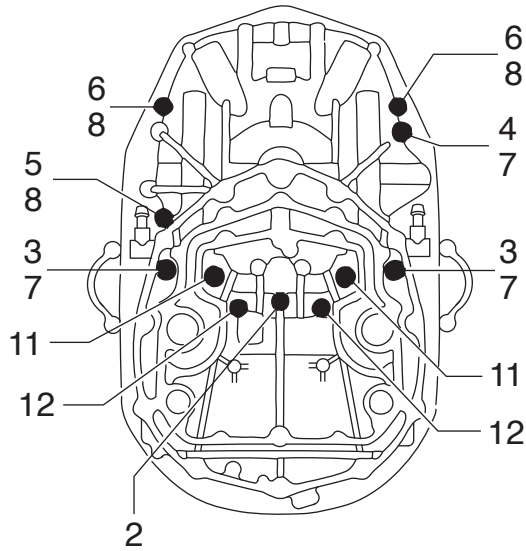
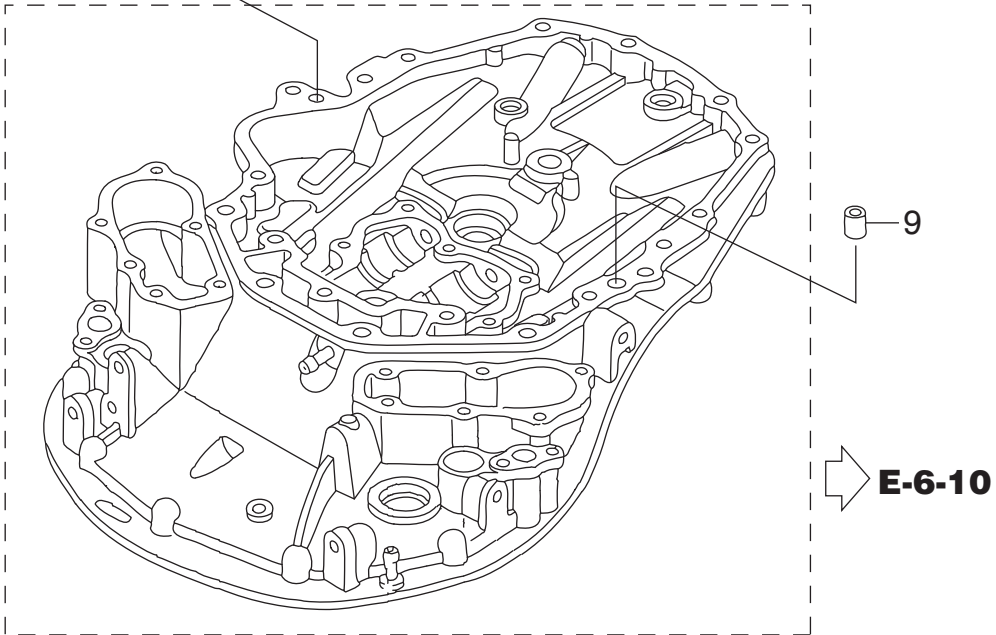
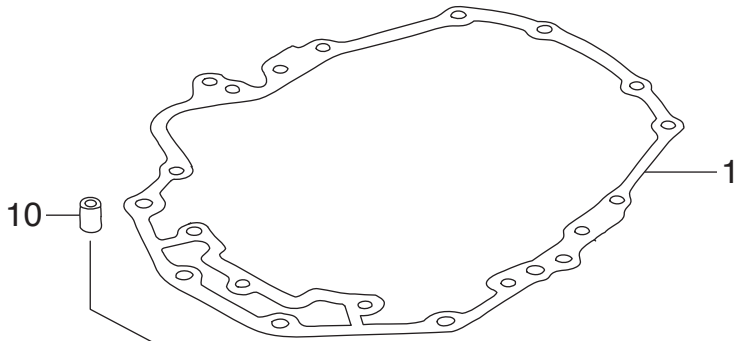





FR. →

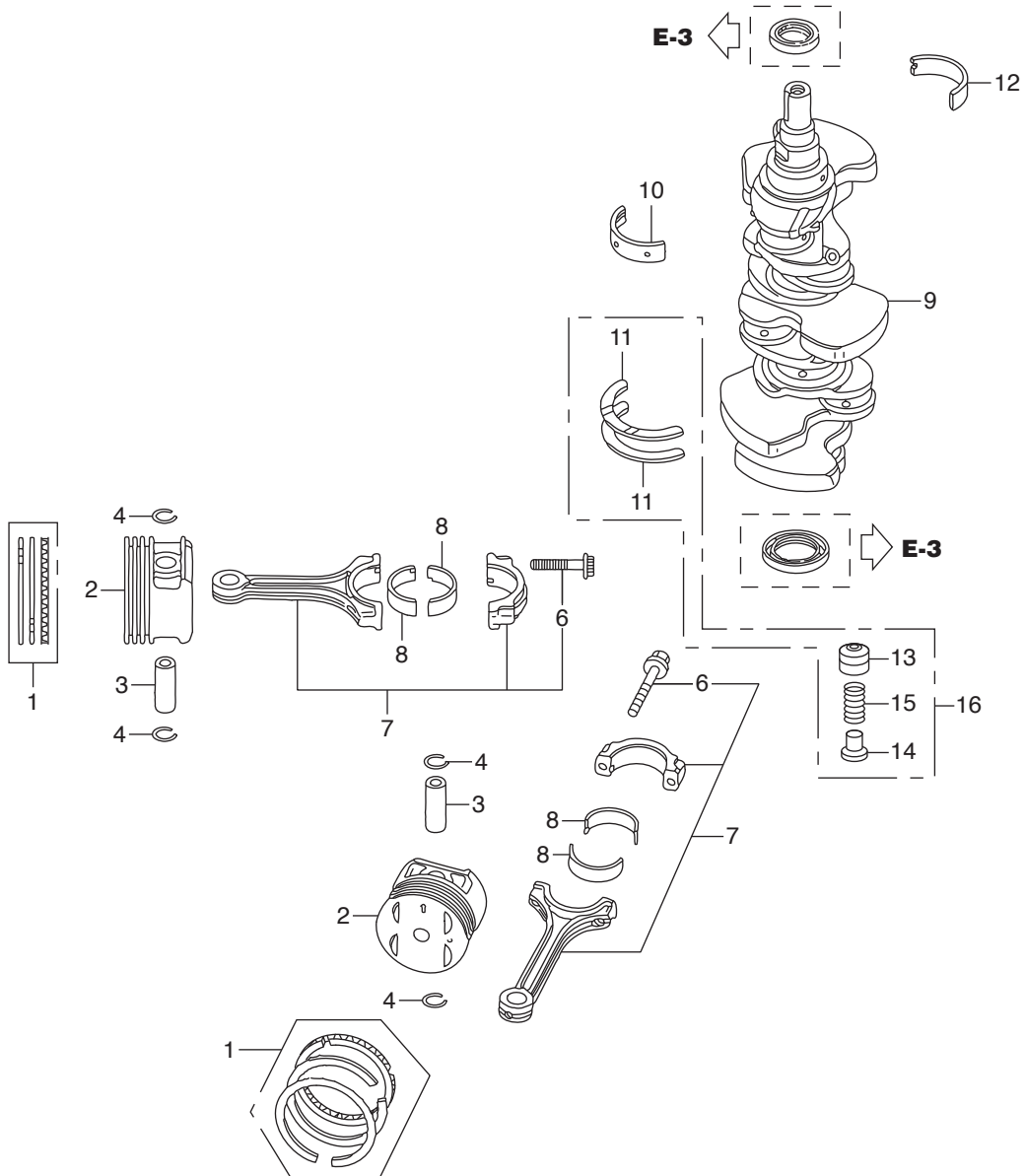

Ref.No.	Part No.	Description	Q' ty	Remarks	
			BF250A		
E-7	1	HZX2-13010-000	RING SET, PISTON(STD.)(RIKEN)	6	
E-7	2	HZX2-13101-000	PISTON	6	
E-7	3	HPEA-13111-000	PIN, PISTON	6	
E-7	4	HP5A-13115-000	CLIP, PISTON PIN	12	
E-7	6	HP8A-13204-A01	BOLT, CONNECTING ROD	12	
E-7	7	HRKG-13210-000	ROD COMP., CONNECTING	6	
E-7	8	HRYE-13211-A01	BEARING A, CONNECTING ROD	12	(BLACK)(TAIHO)
E-7		HRYE-13212-A01	BEARING B, CONNECTING ROD	12	(BROWN)(TAIHO)
E-7		HRYE-13213-A01	BEARING C, CONNECTING ROD	12	(GREEN)(TAIHO)
E-7		HRYE-13214-A01	BEARING D, CONNECTING ROD	12	(YELLOW)(TAIHO)
E-7		HRYE-13215-A01	BEARING E, CONNECTING ROD	12	(PINK)(TAIHO)
E-7	9	HRKG-13310-000	CRANKSHAFT COMP.	1	
E-7	10	HZX2-13321-003	BEARING A, MAIN UPPER(BLACK)	4	(TAIHO)
E-7		HZX2-13322-003	BEARING B, MAIN UPPER(BROWN)	4	(TAIHO)
E-7		HZX2-13323-003	BEARING C, MAIN UPPER(GREEN)	4	(TAIHO)
E-7		HZX2-13324-003	BEARING D, MAIN UPPER(YELLOW)	4	(TAIHO)
E-7		HZX2-13325-003	BEARING E, MAIN UPPER(PINK)	4	(TAIHO)
E-7		HZX2-13326-003	BEARING F, MAIN UPPER(RED)	4	(TAIHO)
E-7	11	HZY3-13331-A03	WASHER, THRUST	2	
E-7		HZY3-13331-A04	WASHER, THRUST	2	#1003867~ #6000081~
E-7	12	HZX2-13341-003	BEARING A, MAIN LOWER(BLACK)	4	(TAIHO)
E-7		HZX2-13342-003	BEARING B, MAIN LOWER(BROWN)	4	(TAIHO)
E-7		HZX2-13343-003	BEARING C, MAIN LOWER(GREEN)	4	(TAIHO)
E-7		HZX2-13344-003	BEARING D, MAIN LOWER(YELLOW)	4	(TAIHO)
E-7		HZX2-13345-003	BEARING E, MAIN LOWER(PINK)	4	(TAIHO)
E-7		HZX2-13346-003	BEARING F, MAIN LOWER(RED)	4	(TAIHO)
E-7	13	HZY3-13391-000	RETAINER, SPRING	1	#1003867~ #6000081~
E-7	14	HZX2-13392-000	SEAT, SPRIND(250)	1	#1003867~ #6000081~
E-7	15	HZY3-13398-003	SPRING,SUPPORT	1	#1003867~ #6000081~

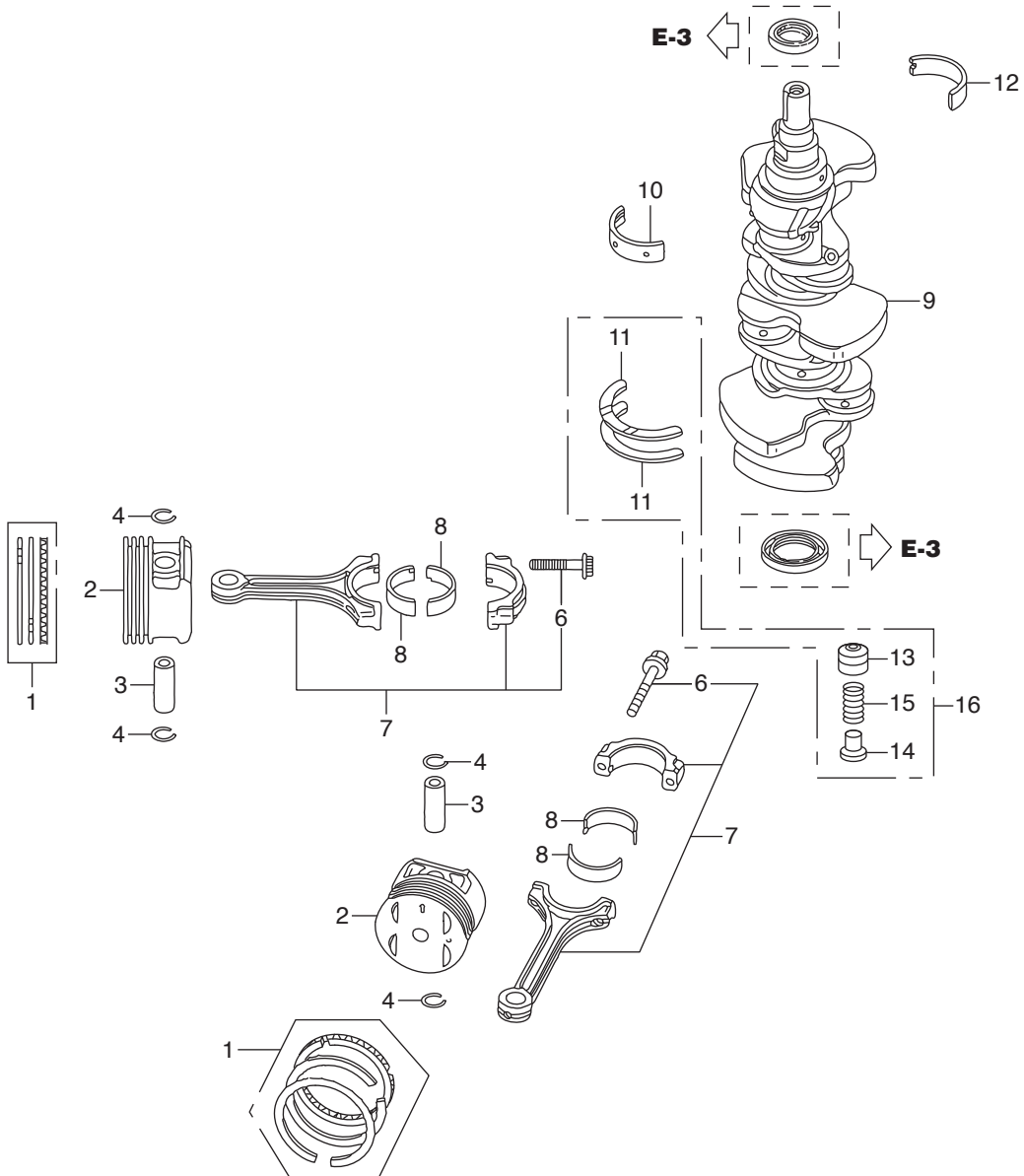



FR. 

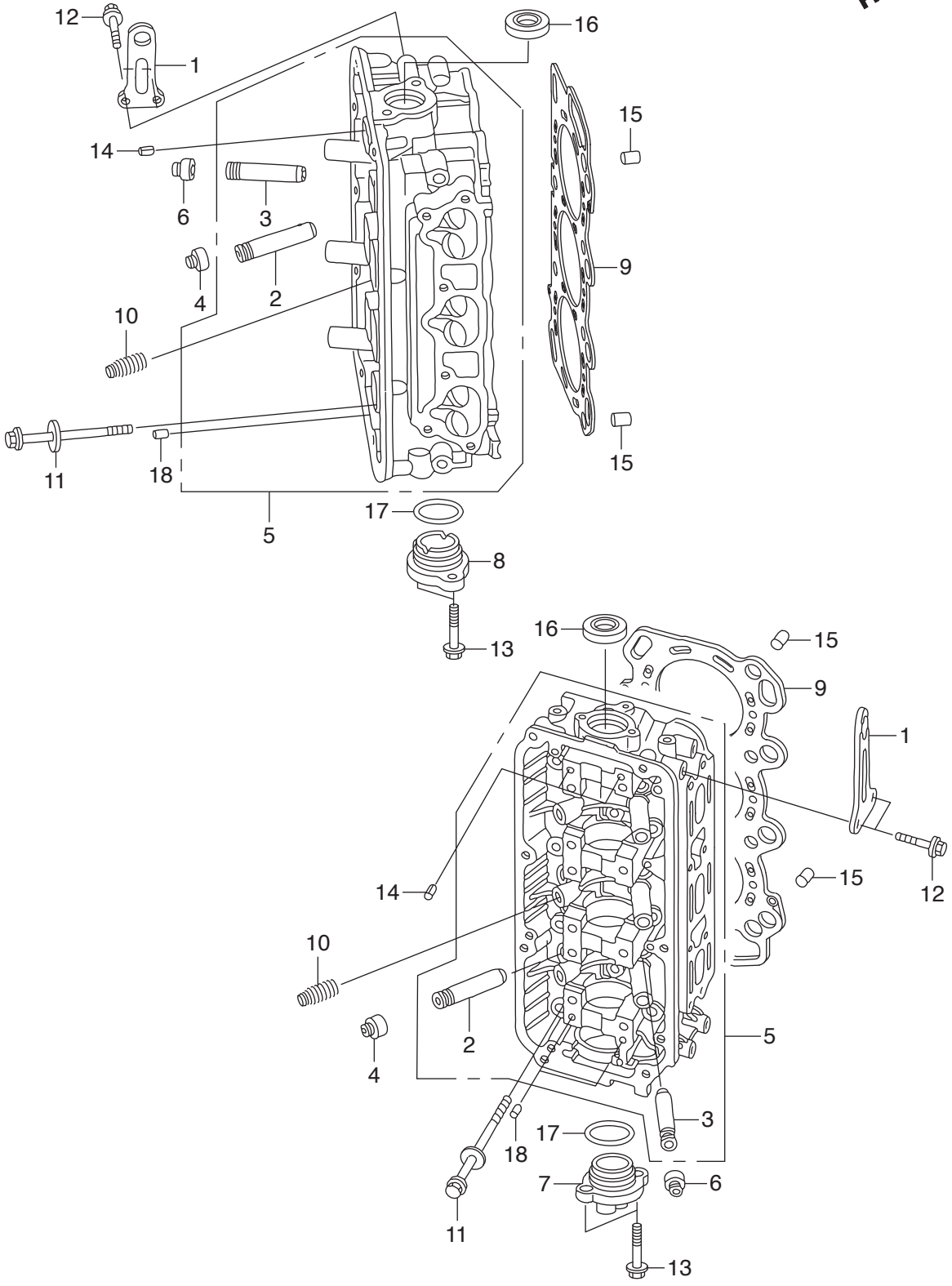



FR. 

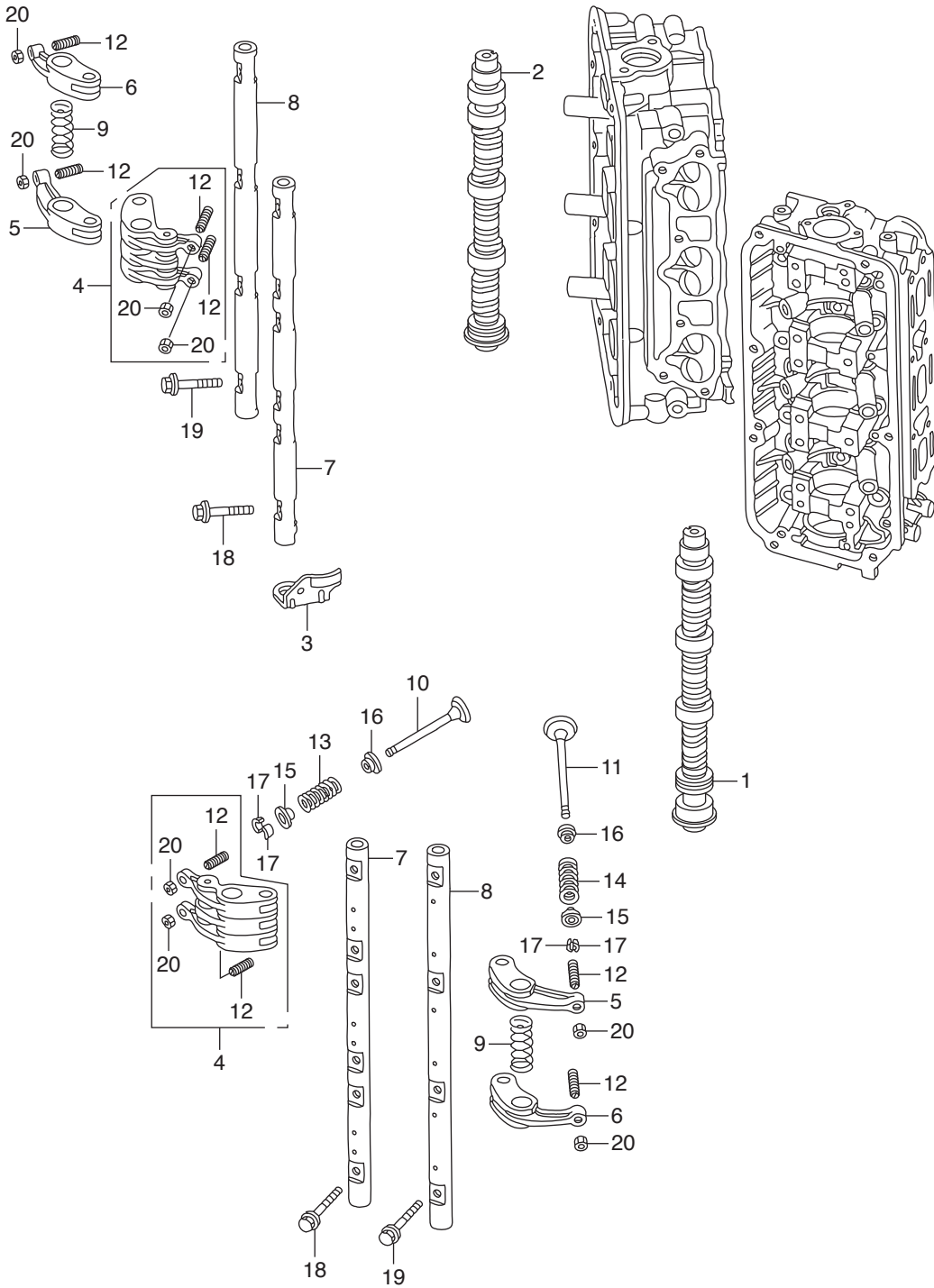





FR. →

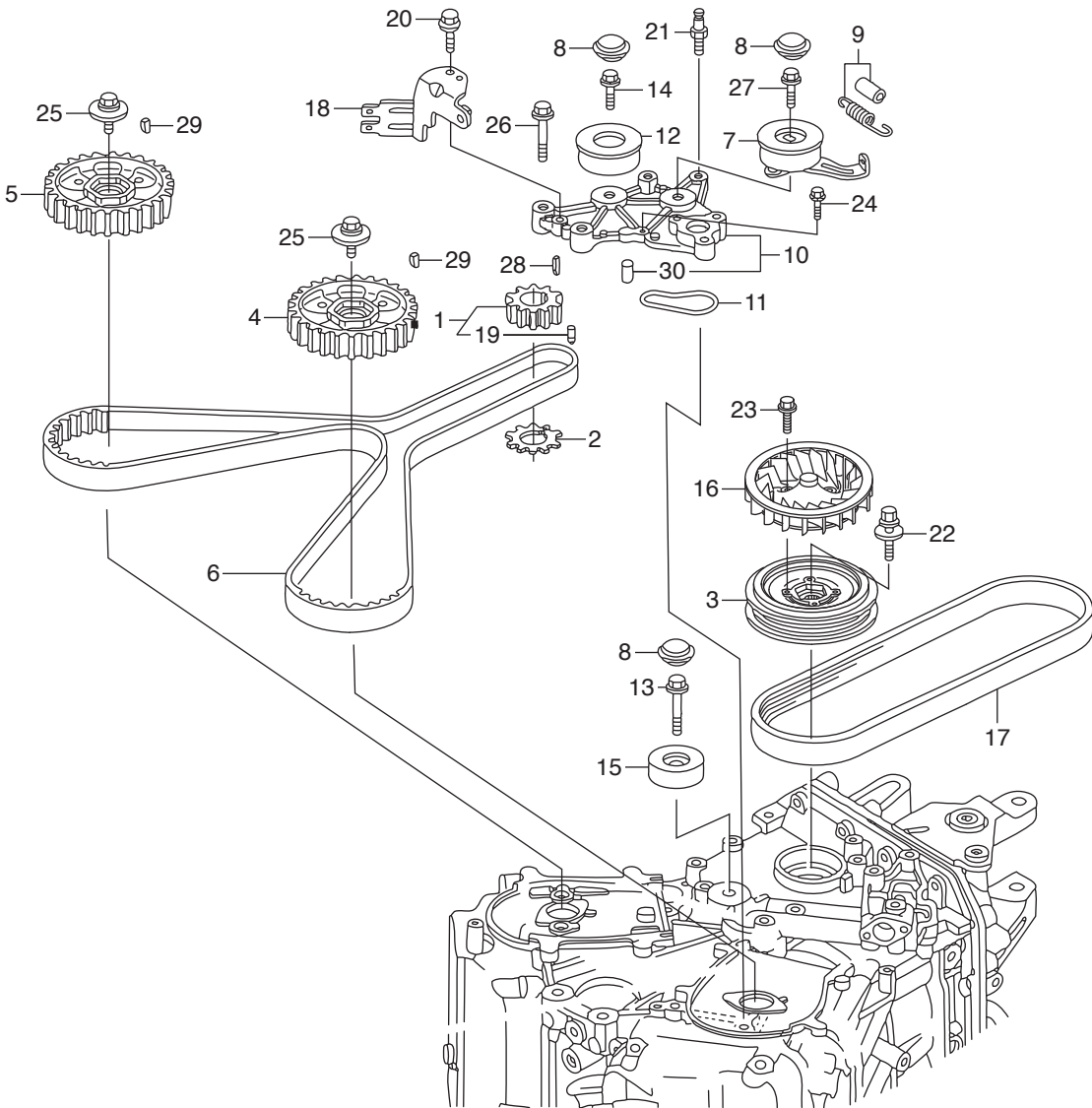

Ref.No.	Part No.	Description	Q' ty	Remarks	
			BF250A		
E-13	1	HZY3-13621-C01	PULLEY, TIMING BELT DRIVE	1	
E-13	2	HZY3-13622-C00	PLATE, TIMING BELT GUIDE	1	
E-13	3	HZX2-13811-000	PULLEY, CRANKSHAFT	1	
E-13	4	HZY3-14261-C00	PULLEY COMP., R. TIMING BELT	1	DRIVEN
E-13	5	HZY3-14270-C00	PULLEY COMP., L. TIMING BELT	1	DRIVEN
E-13	6	HP8A-14400-A01	BELT, TIMING(197YU26 B-333)	1	
E-13	7	HZY3-14510-003	TENSIONER COMP., TIMING BELT	1	
E-13	8	HZY3-14515-000	CAP, TIMING BELT TENSIONER	3	
E-13	9	HZY3-14520-000	SPRING COMP., TIMING BELT	1	ADJUSTING
E-13	10	HZX2-14526-405ZA	BASE COMP., TIMING BELT	1	TENSIONER *NH8* DARK GRAY
E-13	11	HZY3-14529-000	O-RING, TIMING BELT TENSIONER	1	BASE
E-13	12	HZY3-14550-003	IDLER, TIMING BELT(KOYO SEIKO)	1	
E-13	13	HP8A-14551-A01	BOLT, IDLER	1	
E-13	14	HZY3-14553-003	BOLT, TIMING BELT IDLER A	1	
E-13	15	HZY3-14555-003	IDLER B, TIMING BELT	1	
E-13	16	HZX2-19511-000	FAN, COOLING	1	
E-13	17	HZY3-31638-003	BELT, A.C. GENERATOR	1	(6PK745 M-180)
E-13	18	HZY3-32111-010	BRACKET, COUPLER D	1	
E-13	19	HZV0-41122-000	PIN, VERTICAL SHAFT	1	
E-13	20	HZW9-90011-000	BOLT, FLANGE, 6X14(CT200)	1	
E-13	21	HZV5-90012-013	BOLT, TIMING BELT ADJUSTING	1	SPRING
E-13	22	HRJA-90017-003	BOLT-WASHER, 16X49	1	
E-13	23	HZY3-90017-000	BOLT, FLANGE, 6X16	4	
E-13	24	HZY3-90030-000	BOLT, FLANGE, 6X22	1	
E-13	25	HP8A-90031-A01	BOLT-WASHER, 12X35	2	
E-13	26	HZY3-90039-000	BOLT, FLANGE, 10X40	3	
E-13	27	HZY3-90040-000	BOLT, FLANGE, 10X43	1	
E-13	28	HRCA-90704-A00	KEY, 4.5X24	1	
E-13	29	HZY3-90741-000	KEY, SPECIAL	2	

FR. 

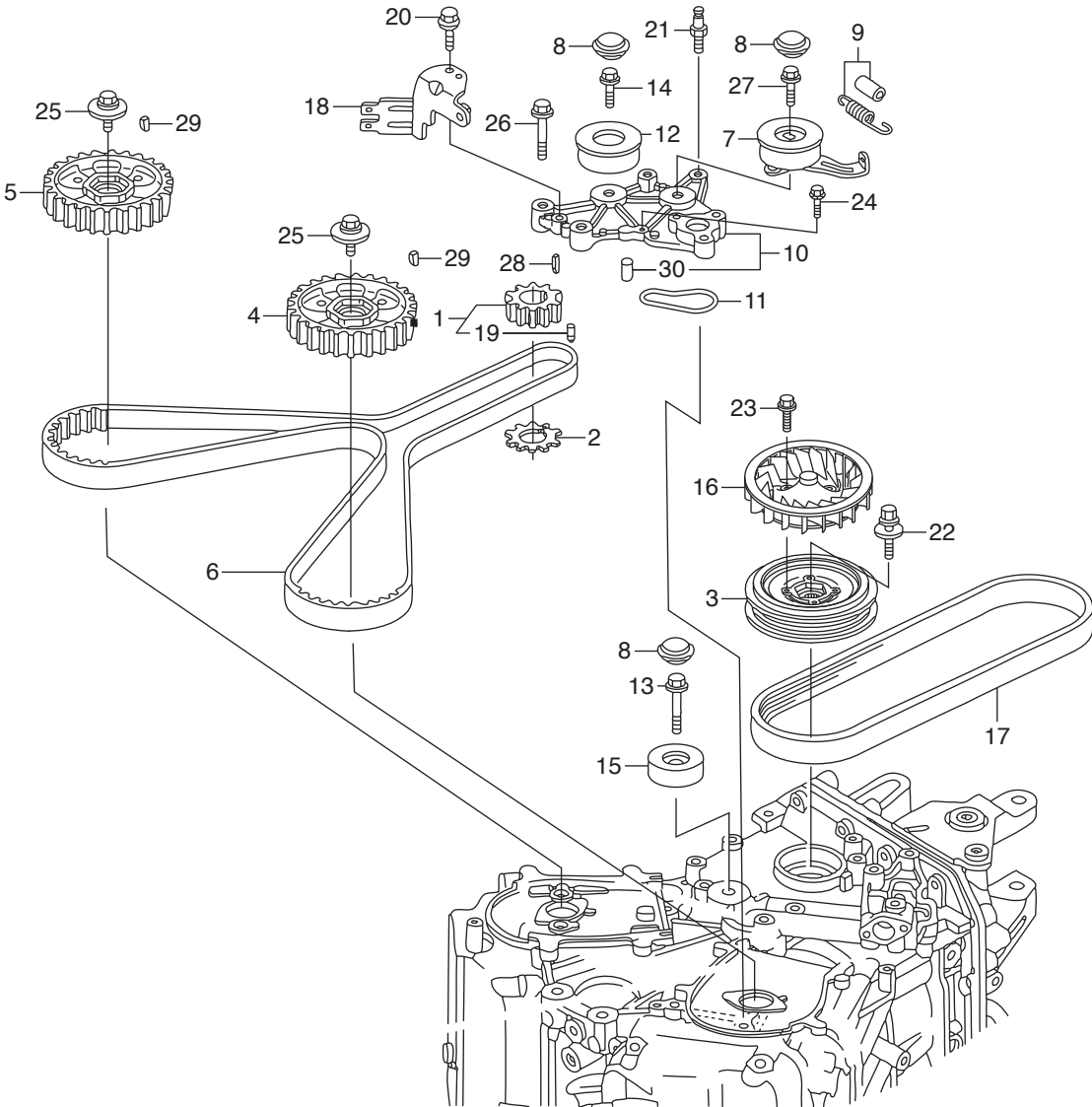



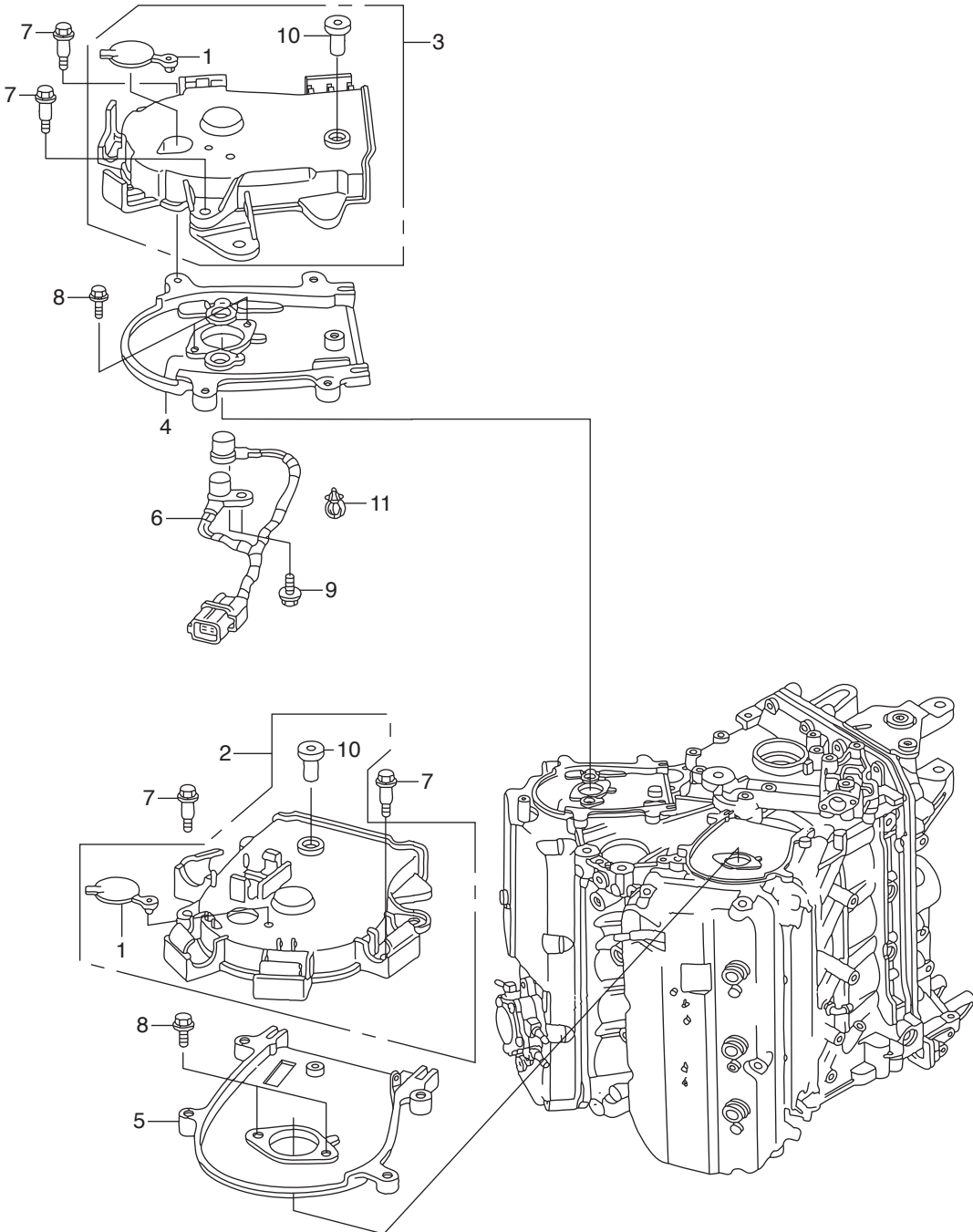



FR. →

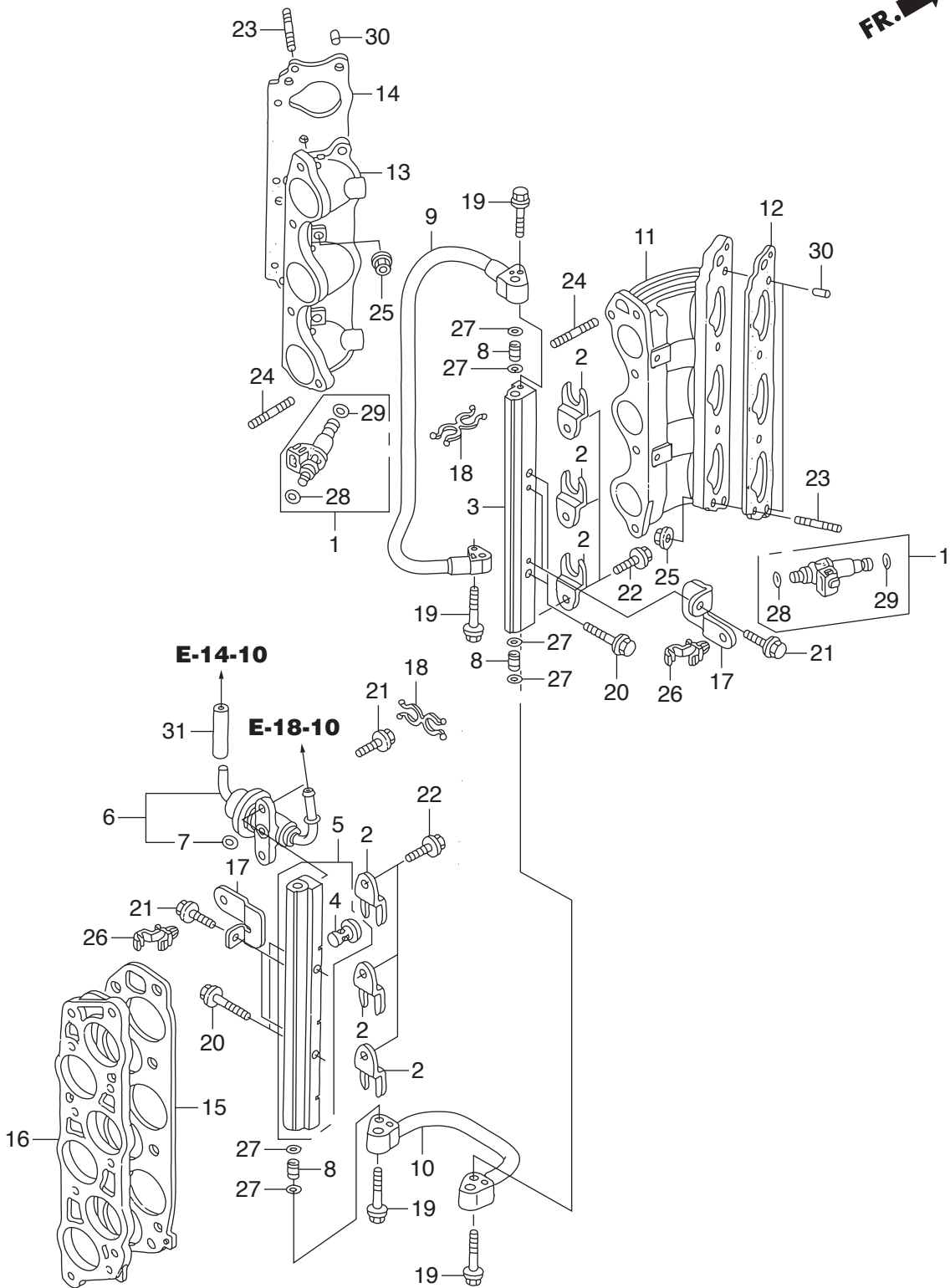



Ref.No.	Part No.	Description	Q' ty	Remarks	
			BF250A		
E-14	1	HZY6-16450-003	INJECTOR ASSY., FUEL	6	
E-14	2	HZY3-16451-000	CLIP, INJECTOR	6	
E-14	3	HZY3-16611-A00	PIPE, R. FUEL	1	
E-14	4	HP5G-16614-003	MESH, FUEL FILTER	1	
E-14	5	HZY3-16620-A00	PIPE COMP., L. FUEL	1	
E-14	6	HZY3-16740-A01	REGULATOR ASSY., PRESSURE	1	
E-14	7	HPG7-16741-005	O-RING, PRESSURE REGULATOR	1	
E-14	8	HZY3-16752-A00	JOINT, FUEL PIPE	3	
E-14	9	HZY3-16755-003	HOSE COMP., FUEL	1	
E-14	10	HZY3-16757-003	HOSE COMP., FUEL JOINT	1	
E-14	11	HZY3-17051-A00	BASE, R. INJECTOR	1	
E-14	12	HRCA-17055-A01	GASKET, FR. INJECTOR BASE	1	
E-14	13	HZY3-17061-A00	BASE, L. INJECTOR	1	
E-14	14	HRCA-17065-A01	GASKET, RR. INJECTOR BASE	1	
E-14	15	HP8E-17105-A01	GASKET, INTAKE MANIFOLD	1	
E-14	16	HZY3-17108-000	SPACER, INTAKE MANIFOLD	1	
E-14	17	HZY3-32112-000	BRACKET, HARNESS CLIP A	4	
E-14	18	HSJ6-78419-003	CLIP D, SPEEDOMETER CABLE	2	
E-14	19	HZW9-90016-000	BOLT, FLANGE, 6X25	4	
E-14	20	HZW9-90019-000	BOLT, FLANGE, 6X35	4	
E-14	21	HZY3-90021-000	BOLT, FLANGE, 6X14	6	
E-14	22	HZY3-90042-000	BOLT, FLANGE, 6X10	6	
E-14	23	HZY3-90043-000	BOLT, STUD, 8X28	8	
E-14	24	HZY3-90044-000	BOLT, STUD, 8X45	2	
E-14	25	HZY3-90205-000	NUT, FLANGE, 8MM	8	
E-14	26	HSB2-90650-003	CLIP, WIRE HARNESS, 10MM	4	
E-14	27	HMJ0-91301-003	O-RING, 7.8X1.9(ARAI)	6	
E-14	28	HPLC-91301-000	O-RING, 7.47X3.6	6	
E-14	29	HPNA-91302-003	O-RING, 7.45X3.61(NOK)	6	

FR. →

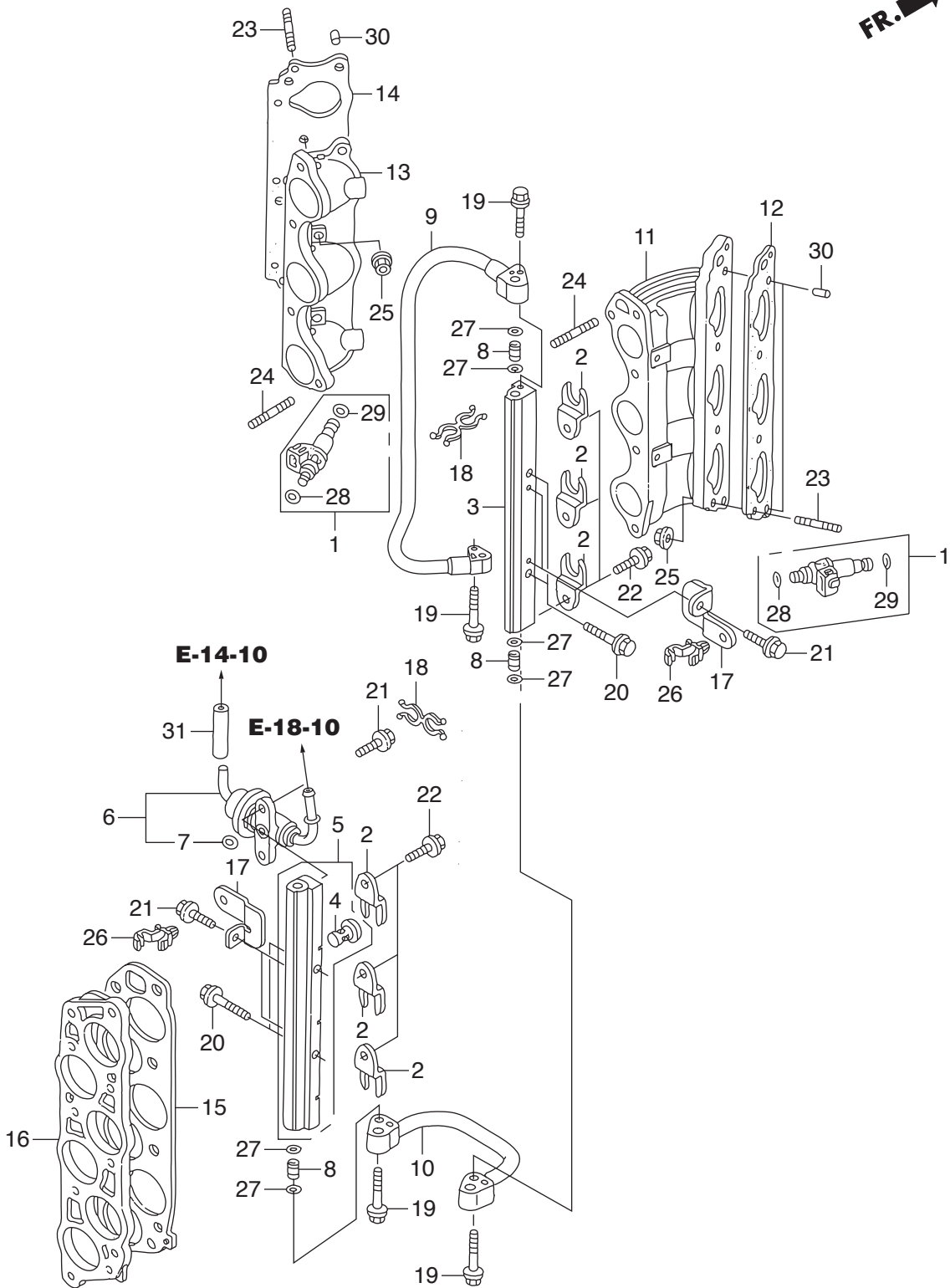



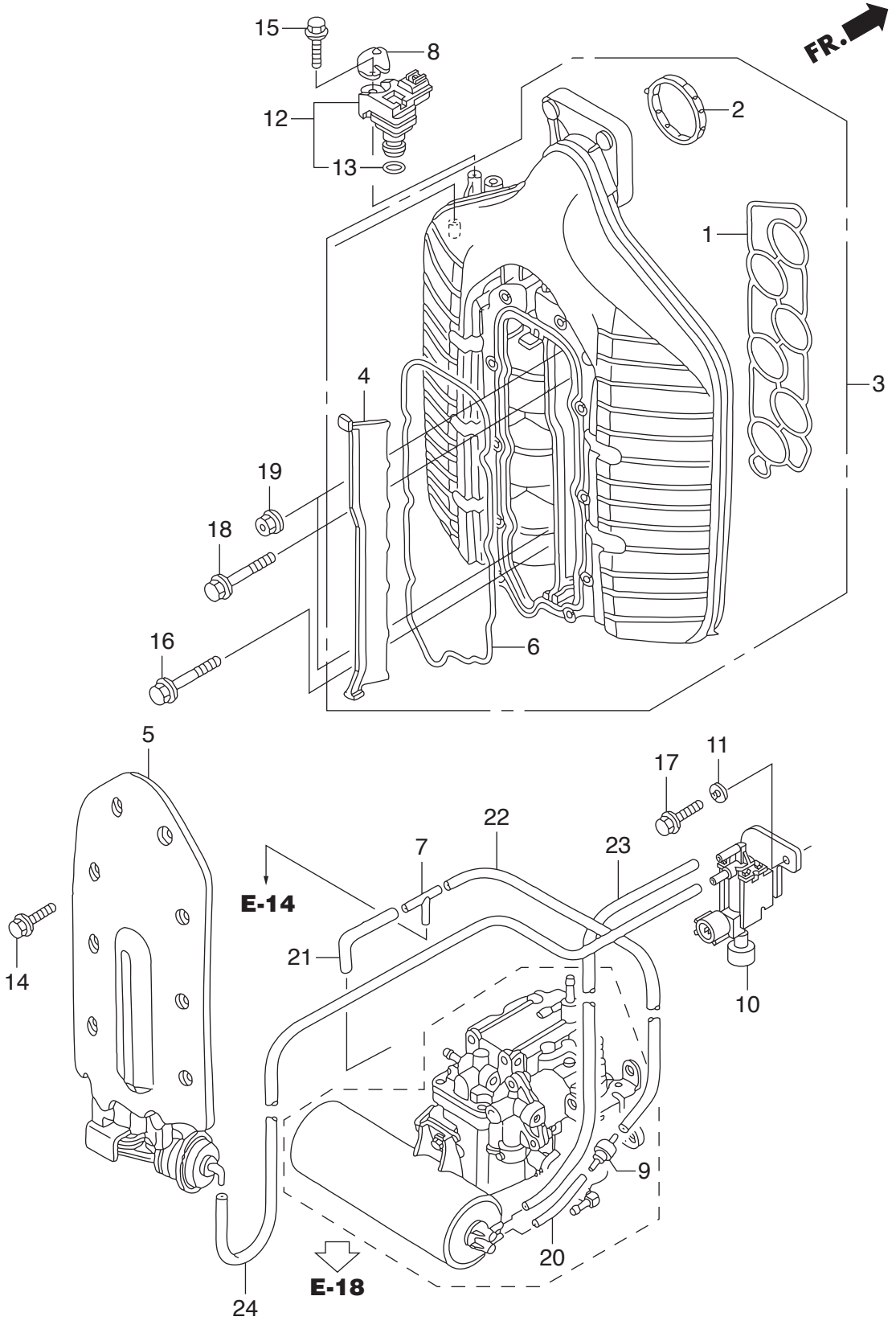

Ref.No.	Part No.	Description	Q' ty	Remarks	
			BF250A		
E-14-10	1	HZY3-17105-004	GASKET, INTAKE MANIFOLD	1	
E-14-10	2	HZY3-17109-004	PACKING, THROTTLE BODY	1	
E-14-10	3	HZY3-17110-003	MANIFOLD COMP., INTAKE	1	
E-14-10	4	HZY3-17113-003	PLATE, INTAKE MANIFOLD CENTER	1	
E-14-10	5	HZY3-17130-003ZA	COVER COMP., INTAKE MANIFOLD	1	*NH8* DARK GRAY
E-14-10	6	HZY3-17138-004	PACKING, INTAKE MANIFOLD UP	1	COVER
E-14-10	7	HMG9-17201-000	JOINT A, VACUUM TUBE	1	
E-14-10	8	HZY3-32128-000	BRACKET, SENSOR CORD	1	
E-14-10	9	HPM4-36145-004	VALVE, CHECK	1	
E-14-10	10	HZY3-36163-003	VALVE ASSY., AIR BYPASS	1	
E-14-10	11	HP8D-36165-J00	WASHER, CONICAL SPRING(5)	1	
E-14-10	12	HRNA-37830-A01	SENSOR ASSY., MAP	1	
E-14-10	13	HPGK-37835-A01	O-RING	1	
E-14-10	14	HZY3-90023-000	BOLT, FLANGE, 6X22	10	
E-14-10	15	HZY3-90029-000	BOLT-WASHER, 5X18	1	
E-14-10	16	HZY3-90031-000	BOLT, FLANGE, 6X32	1	
E-14-10	17	HZY3-90058-000	BOLT, FLANGE, 5X10	1	
E-14-10	18	HZW4-90156-000	BOLT, FLANGE, 8X50	7	
E-14-10	19	HZY3-90205-000	NUT, FLANGE, 8MM	2	
E-14-10	20	HCO-95001-35040-40	TUBE, FUEL, 3.5X40	1	(HC-95001-35001-60M)
E-14-10	21	HCO-95001-35130-40	TUBE, FUEL, 3.5X130	1	(HC-95001-35001-60M)
E-14-10	22	HCO-95001-35540-40	TUBE, FUEL, 3.5X540	1	(HC-95001-35001-60M)
E-14-10	23	HCO-95001-35590-60	TUBE, FUEL, 3.5X590	1	(HC-95001-35001-60M)
E-14-10	24	HCO-95001-35600-40	TUBE, FUEL, 3.5X600	1	(HC-95001-35001-60M)

FR. 

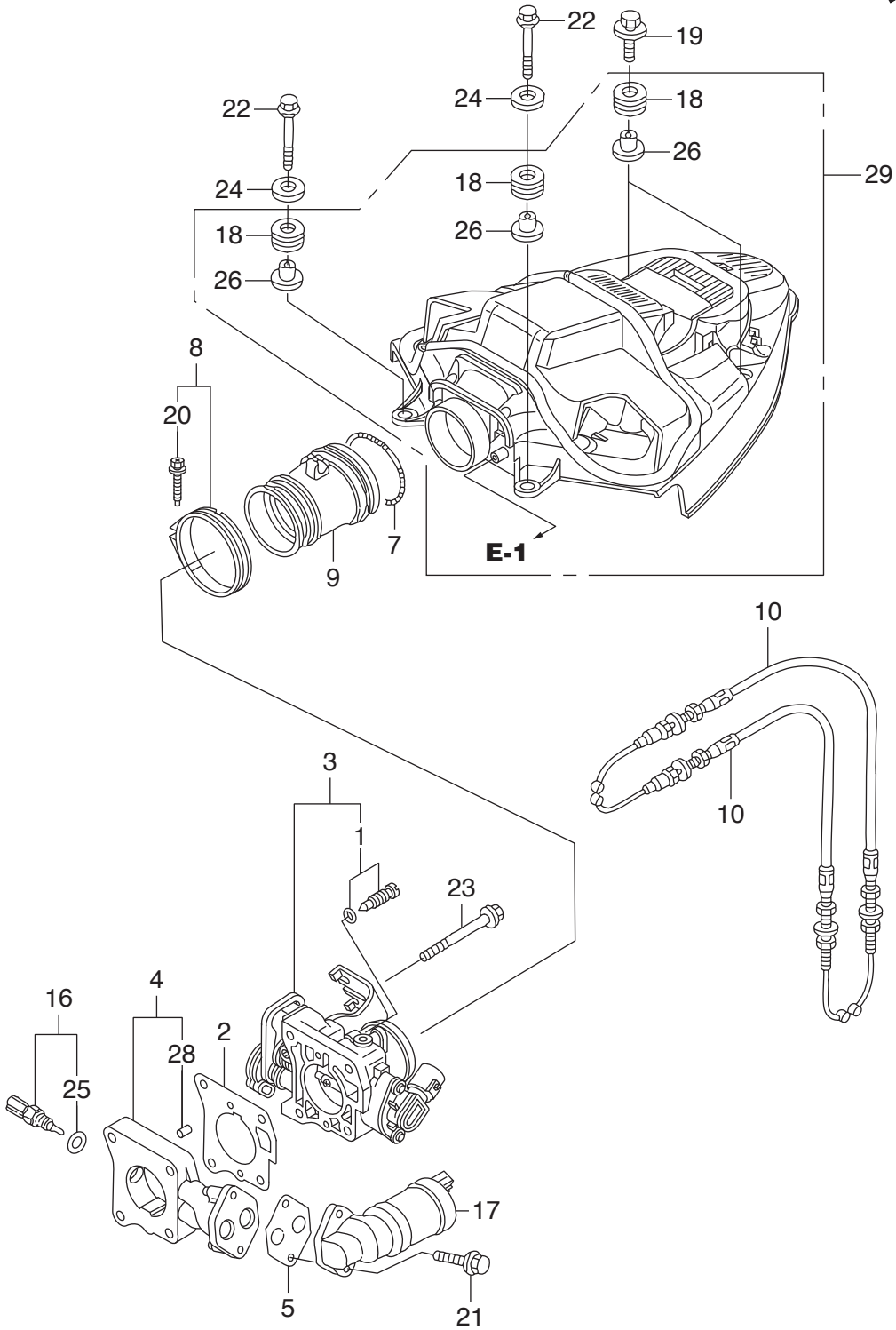

Ref.No.	Part No.	Description	Q' ty	Remarks	
			BF250A		
E-15	1	HZY3-16016-003	SCREW SET	1	
E-15	2	HZY3-16176-000	GASKET, THROTTLE BODY	1	
E-15	3	HZY3-16400-A01	THROTTLE BODY ASSY.	1	
E-15	4	HZX2-16404-000	SPACER, THROTTLE BODY	1	
E-15	5	HZY3-16405-000	GASKET, EAC VALVE	1	
E-15	7	HPY3-17249-000	SPRING, AIR FLOW TUBE	1	
E-15	8	HZY9-17315-000	BAND, AIR FLOW	1	
E-15	9	HZX2-17374-000	GROMMET, SILENCER	1	
E-15	10	HZY3-17910-013	CABLE COMP., THROTTLE	2	
E-15	16	HZW5-35665-003	SENSOR ASSY., AIR TEMP	1	
E-15	17	HZY3-36550-003	VALVE ASSY., EAC	1	
E-15	18	HZV5-40102-000	GROMMET, UNDER CASE	4	
E-15	19	HZW1-90013-000	BOLT-WASHER, 6X25	2	
E-15	20	HZY9-90017-000	BOLT-WASHER, 5X30	1	
E-15	21	HZY3-90030-000	BOLT, FLANGE, 6X22	2	
E-15	22	HZY3-90034-000	BOLT, FLANGE, 6X60	2	
E-15	23	HZY3-90037-000	BOLT, FLANGE, 8X65	4	
E-15	24	HZY3-90508-000	WASHER, PLAIN, 6MM	2	
E-15	25	HP0A-91303-A02	O-RING	1	
E-15	26	HZV5-91553-010	COLLAR, C.D.I. UNIT CASE	4	
E-15	28	HCO-94301-06100	DOWEL PIN, 6X10	2	
E-15	29	HZX2-19540-010	COVER ASSY., COOLING FAN	1	

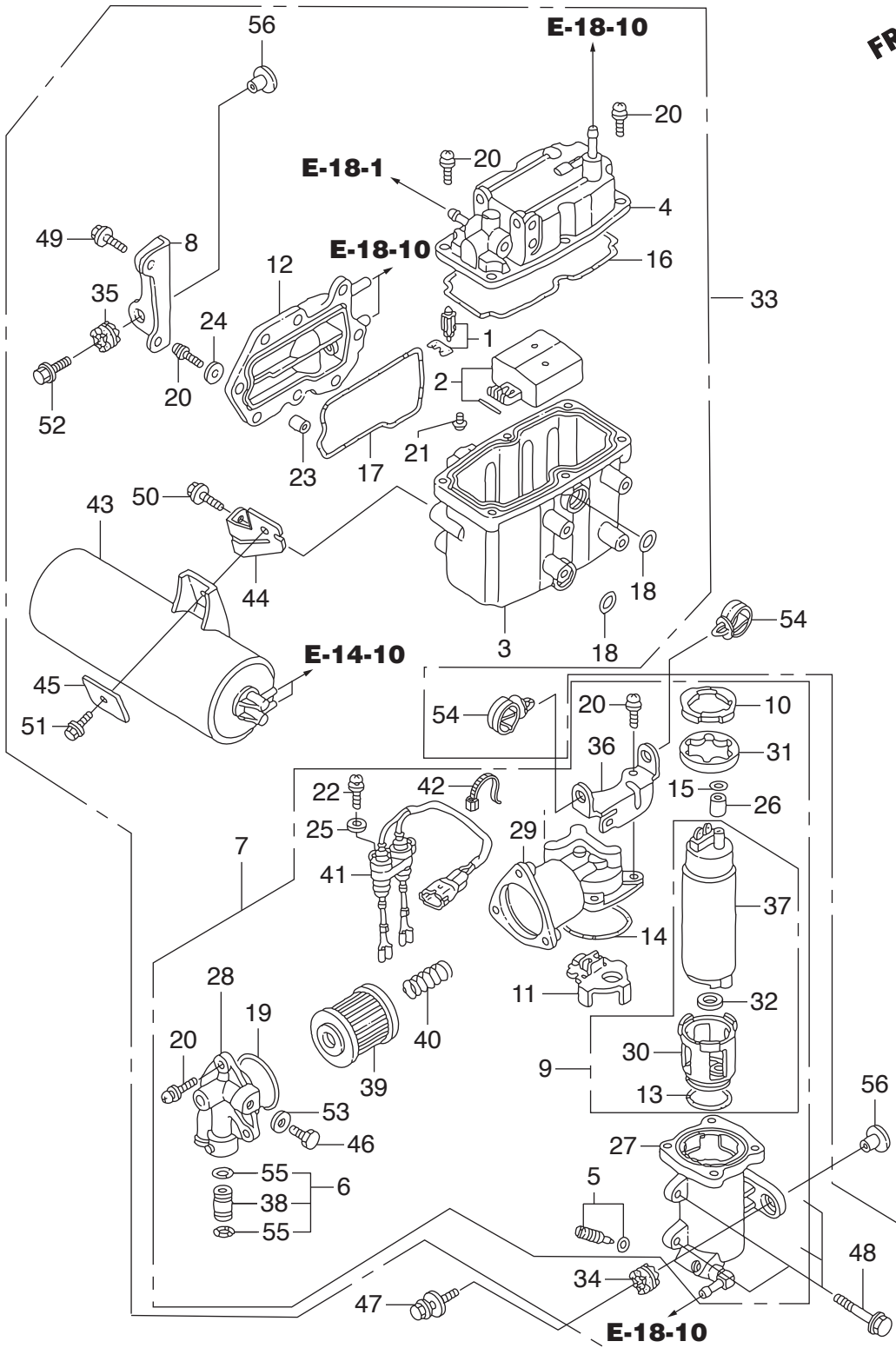



Ref.No.	Part No.	Description	Q' ty	Remarks	
			BF250A		
E-18	1	HZY3-16011-A01	VALVE SET, FLOAT	1	
E-18	2	HZY3-16013-000	FLOAT SET	1	
E-18	3	HZY3-16015-000	BODY	1	
E-18	4	HZX2-16020-003	COVER COMP.	1	
E-18	5	HZY3-16024-000	SCREW SET, DRAIN	1	
E-18	6	HZY3-16026-000	JOINT SET	1	
E-18	7	HZX2-16030-003	PUMP UNIT SET A, FUEL	1	
E-18	8	HZY3-16031-010	STAY, PLATE	1	
E-18	9	HZY3-16036-003	PUMP UNIT SET B, FUEL	1	
E-18	10	HZY3-16041-000	PLATE	1	
E-18	11	HZY3-16042-000	HOLDER	1	
E-18	12	HZY3-16061-000	COVER, WATER JACKET	1	
E-18	13	HZY3-16072-000	O-RING	1	
E-18	14	HZY3-16073-000	O-RING	1	
E-18	15	HZY3-16074-000	O-RING	1	
E-18	16	HZY3-16075-000	O-RING	1	
E-18	17	HZY3-16076-000	O-RING	1	
E-18	18	HZY3-16077-000	O-RING	2	
E-18	19	HZY3-16078-000	O-RING	1	
E-18	20	HZW5-16081-010	SCREW-WASHER	21	
E-18	21	HZY3-16082-000	SCREW, PAN	2	
E-18	22	HZY3-16083-000	SCREW, WASHER	1	
E-18	23	HZW5-16086-000	COLLAR	8	
E-18	24	HZW5-16087-000	WASHER, PLAIN	8	
E-18	25	HZY3-16087-000	WASHER, PLAIN	1	
E-18	26	HZY3-16088-000	COLLAR	1	
E-18	27	HZX2-16701-003	CASE COMP., PUMP	1	
E-18	28	HZY3-16708-000	COVER, PUMP	1	
E-18	29	HZW5-16715-023	COVER, PUMP(A)	1	

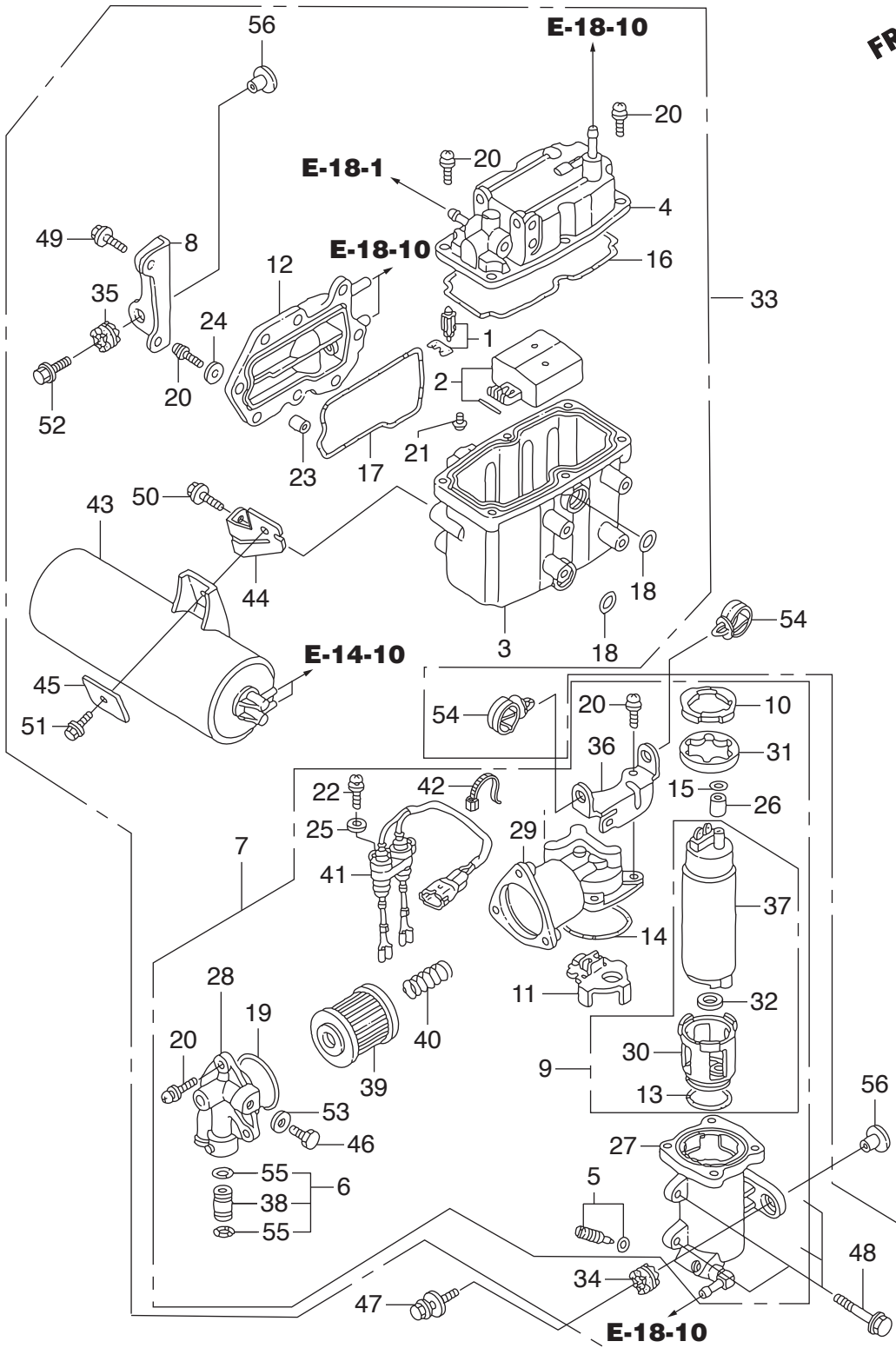

Ref.No.		Part No.	Description	Q' ty	Remarks
				BF250A	
E-18	30	HZY6-16718-013	INSULATOR COMP.	1	
E-18	31	HZY3-16721-000	INSULATOR	1	
E-18	32	HZY6-16723-003	RING	1	
E-18	33	HZX2-16730-003	SEPARATOR ASSY., VAPOR	1	
E-18	34	HZW5-16733-000	GROMMET, VAPOR SEPARATOR	1	
E-18	35	HZY3-16733-000	GROMMET, VAPOR SEPARATOR	2	
E-18	36	HZY3-16734-000	STAY, PLATE	1	
E-18	37	HZY3-16735-004	PUMP UNIT, FUEL	1	
E-18	38	HZY3-16752-000	JOINT, FUEL PIPE	1	
E-18	39	HZY3-16911-010	SCREEN COMP., FUEL STRAINER	1	
E-18	40	HZY3-16913-000	SPRING, SET	1	
E-18	41	HZX2-32166-003	HARNESS COMP.	1	
E-18	42	HZW5-32168-003	BAND	1	
E-18	43	HPR7-36361-A01	TANK COMP., VACUUM	1	
E-18	44	HZY3-36362-000	STAY, VACUUM TANK	1	
E-18	45	HZY3-36620-000	PLATE	1	
E-18	46	HPP4-90009-E01	BOLT, SEALING, 6MM	1	
E-18	47	HZW1-90014-000	BOLT-WASHER, 8X35	1	
E-18	48	HZW9-90016-000	BOLT, FLANGE, 6X25	4	
E-18	49	HZY3-90017-000	BOLT, FLANGE, 6X16	2	
E-18	50	HZY3-90021-000	BOLT, FLANGE, 6X14	2	
E-18	51	HZY3-90050-000	BOLT, FLANGE, 6X12	1	
E-18	52	HZY3-90054-000	BOLT, FLANGE, 8X35	2	
E-18	53	HPD6-90430-003	WASHER, SEALING, 6MM	1	
E-18	54	HZB7-90691-003	CLIP, HARNESS	2	
E-18	55	HMJ0-91301-003	O-RING, 7.8X1.9(ARAI)	2	
E-18	56	HZW1-91554-000	COLLAR, 8.5X14.5	3	

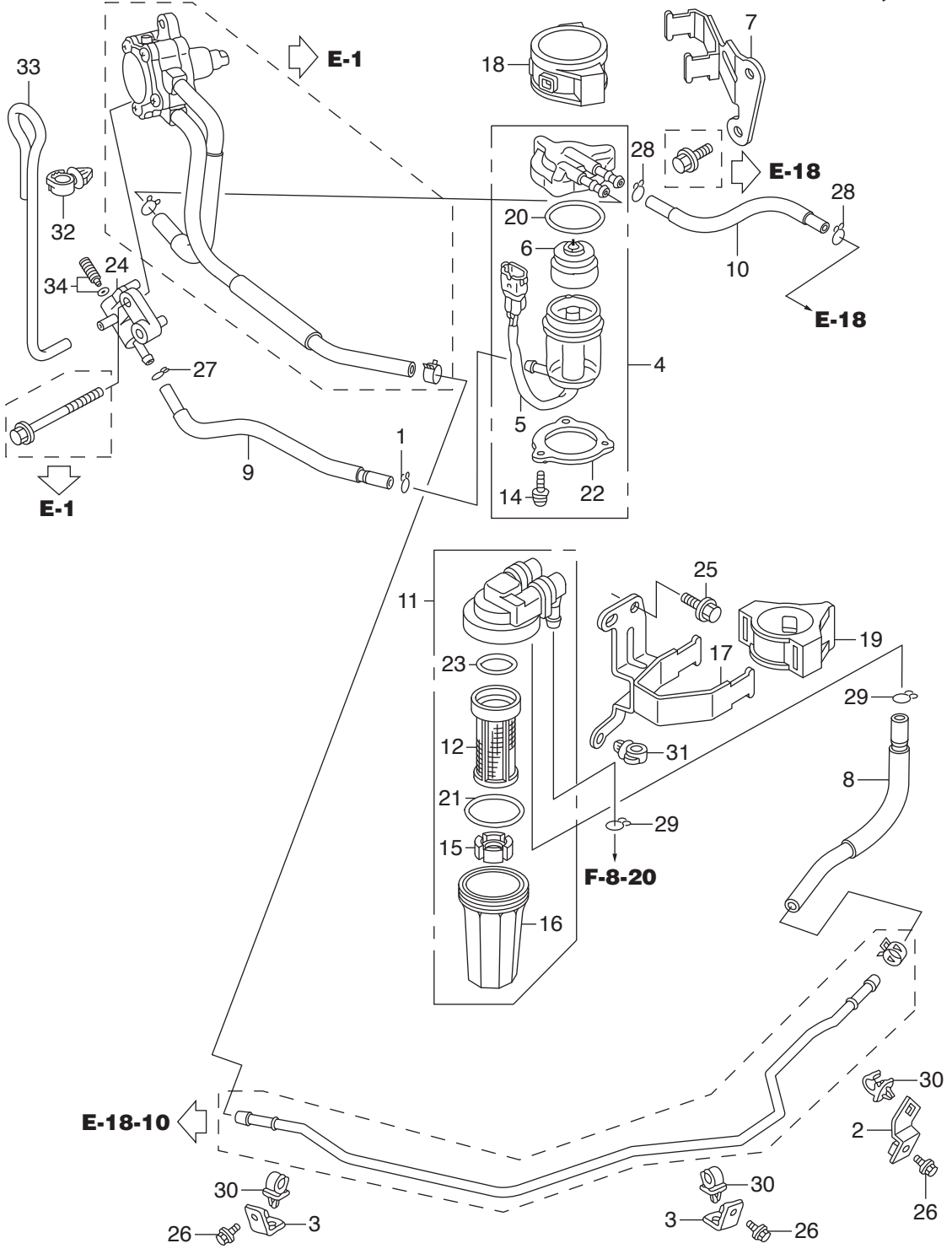

Ref.No.	Part No.	Description	Q' ty	Remarks	
			BF250A		
E-18-1	1	HGHB-16163-600	CLIP, TUBE	1	
E-18-1	2	HZY3-16753-000	STAY, FUEL PIPE A	1	
E-18-1	3	HZY3-16754-000	STAY, FUEL PIPE B	2	
E-18-1	4	HZX2-16800-003	SEPARATOR ASSY., WATER	1	
E-18-1	5	HZX2-16805-003	CUP SET, WATER SEPARATOR	1	
E-18-1	6	HZY3-16807-003	BUFFER, PLATE	1	
E-18-1	7	HZX2-16814-000	STAY, WATER SEPARATOR	1	
E-18-1	8	HZX2-16860-000	TUBE COMP. B, FUEL	1	
E-18-1	9	HZX2-16880-000	TUBE COMP. D, FUEL	1	
E-18-1	10	HZX2-16890-000	TUBE COMP. E, FUEL	1	
E-18-1	11	HZX2-16900-003	STRAINER ASSY., FUEL	1	
E-18-1	12	HZZ5-16901-003	FILTER	1	
E-18-1	14	HZY3-16904-003	SCREW, PAN, 5X12	3	
E-18-1	15	HZZ5-16906-003	FLOAT	1	
E-18-1	16	HZX2-16912-003	CUP	1	
E-18-1	17	HZX2-16914-000	STAY, FUEL STRAINER	1	
E-18-1	18	HZY3-16915-010	SUSPENSION, STRAINER	1	
E-18-1	19	HZZ5-16915-000	SUSPENSION, STRAINER	1	
E-18-1	20	HZY3-16918-003	O-RING	1	
E-18-1	21	HZZ5-16918-003	O-RING	1	
E-18-1	22	HZY3-16919-003	PLATE	1	
E-18-1	23	HZZ5-16919-003	O-RING	1	
E-18-1	24	HZX2-16940-003	COCK ASSY., FUEL DRAIN	1	
E-18-1	25	HZW9-90014-000	BOLT, FLANGE, 6X10	2	
E-18-1	26	HZY3-90056-000	BOLT, FLANGE, 6X12	3	
E-18-1	27	H921-90602-000	CLIP, TUBE(B8)	1	
E-18-1	28	HZV0-90604-000	CLIP, TUBE(B12)	2	
E-18-1	29	HZV4-90605-000	CLIP, TUBE(B12.5)	2	
E-18-1	30	HKG4-90659-000	CLAMP, WIRE, 8MM	3	

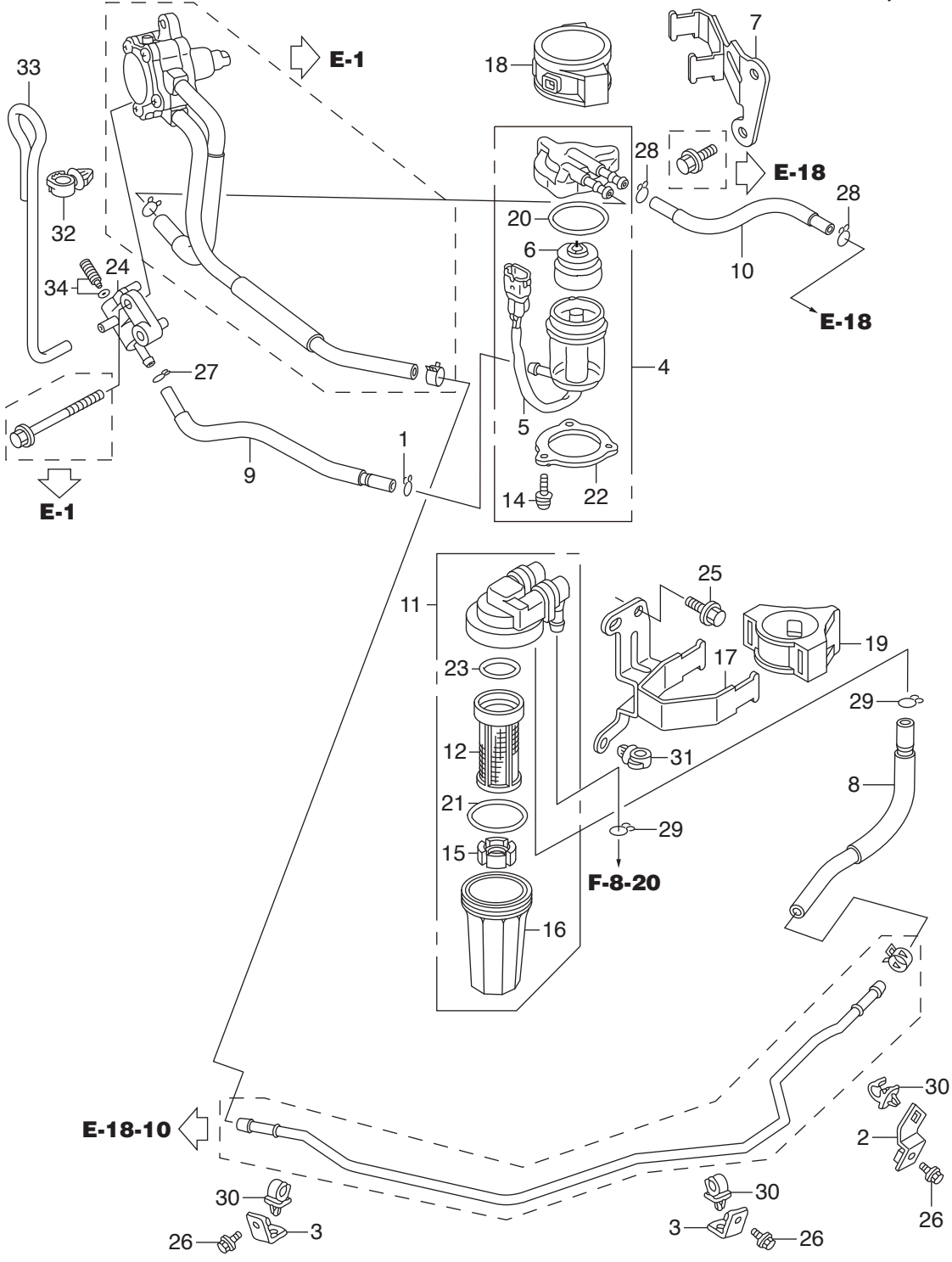



FR. 

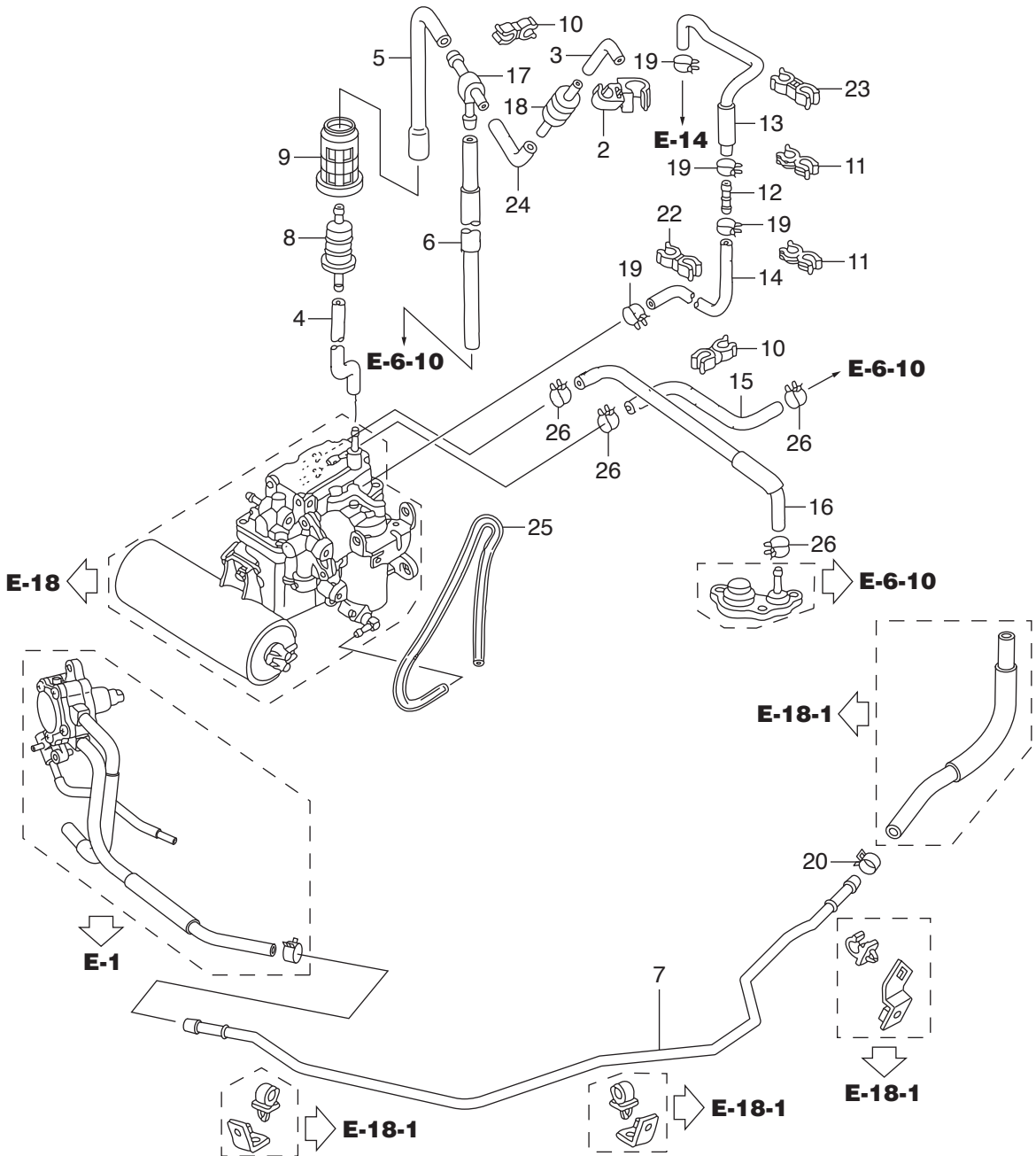



Ref.No.	Part No.	Description	Q' ty	Remarks	
			BF250A		
E-18-10	2	HZY3-16193-A00	CLAMP, CHECK VALVE	1	
E-18-10	3	HZY3-16196-A00	TUBE, CHECK VALVE	1	
E-18-10	4	HZY3-16197-000	TUBE A, AIR VENT	1	
E-18-10	5	HZY3-16198-A00	TUBE B, AIR VENT	1	
E-18-10	6	HZY3-16199-A00	TUBE COMP., AIR VENT	1	
E-18-10	7	HZY3-16751-000	PIPE, FUEL	1	
E-18-10	8	H759-16911-003	STRAINER, FUEL PUMP	1	
E-18-10	9	HZW5-16915-000	SUSPENSION, STRAINER	1	
E-18-10	10	HVM0-16965-771	CLAMP, HOSE	2	
E-18-10	11	HKY7-17450-740	CLIP, TUBE	2	
E-18-10	12	HZY3-17721-000	JOINT, FUEL RETURN	1	
E-18-10	13	HZY3-17723-A01	HOSE A, PRESSURE REGULATOR	1	RETURN
E-18-10	14	HZY3-17724-010	HOSE B, PRESSURE REGULATOR	1	RETURN
E-18-10	15	HZY3-19258-010	TUBE, WATER IN.	1	
E-18-10	16	HZY3-19259-000	TUBE, WATER OUTLET	1	
E-18-10	17	HZY6-19269-000	T-JOINT	1	
E-18-10	18	HZY6-36135-003	VALVE, CHECK	1	
E-18-10	19	HZW5-90601-030	CLAMP, TUBE(D10.7)	4	
E-18-10	20	HZW5-90602-030	CLAMP, TUBE(D12)	1	
E-18-10	22	HMB1-90655-921	CLIP, WIRE	1	
E-18-10	23	HSL0-91592-A51	CLAMP, FUEL TUBE	1	
E-18-10	24	HCO-95001-35055-40	TUBE, FUEL, 3.5X55	1	(HC-95001-35001-60M)
E-18-10	25	HCO-95003-05060-31	TUBE, VINYL, 3.5X6.5X600	1	(HC-95003-05001-60M)
E-18-10	26	HZY3-90601-030	CLAMP, TUBE(D10.5)	4	

FR. 

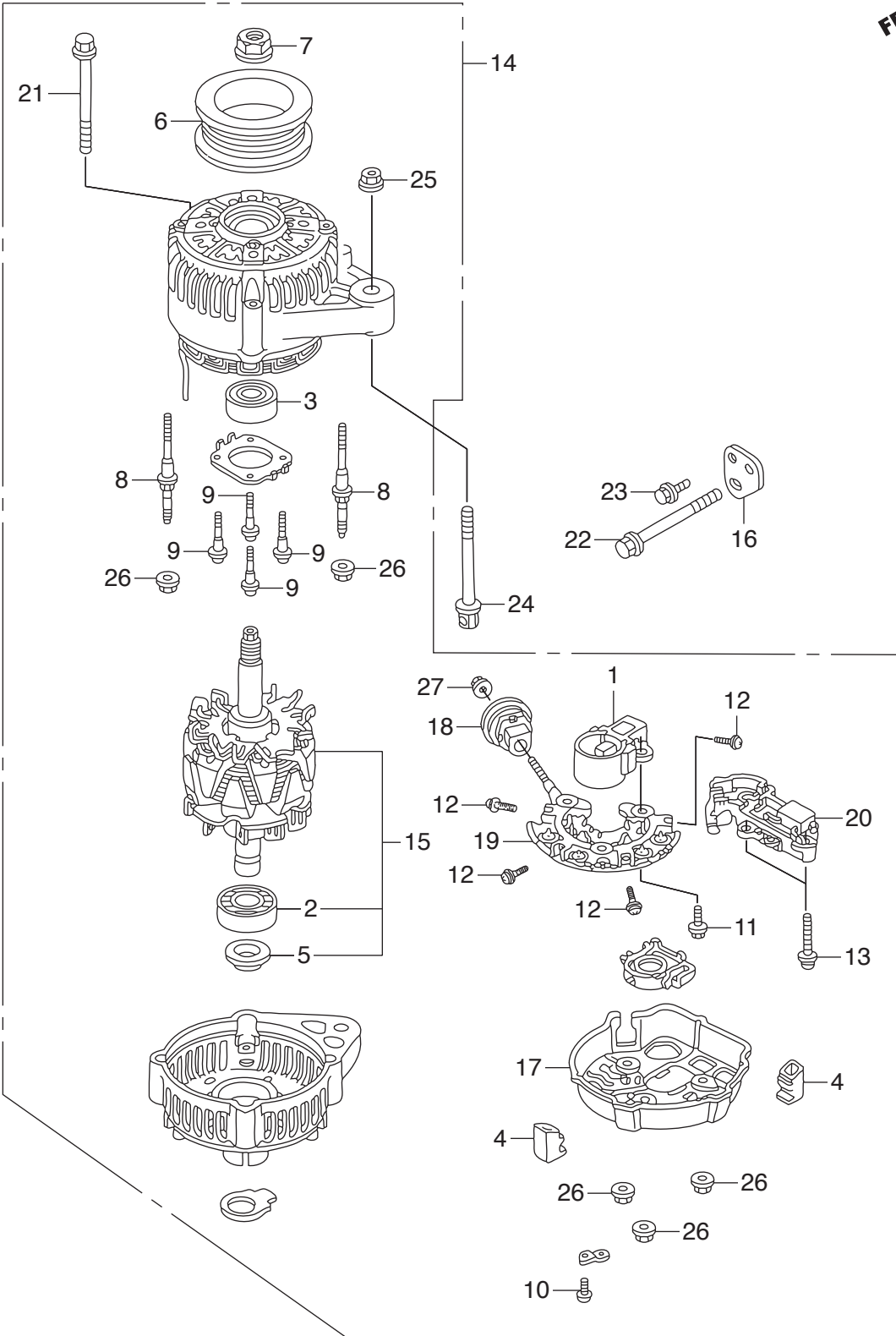

Ref.No.	Part No.	Description	Q' ty	Remarks	
			BF250A		
E-19	1	HPR7-31105-A01	HOLDER ASSY., BRUSH	1	
E-19	2	HPT0-31111-003	BEARING, RR. GENERATOR	1	
E-19	3	HPT0-31114-013	BEARING, FR. GENERATOR	1	
E-19	4	HPT0-31118-003	BUSH, INSULATION	4	
E-19	5	HPD1-31138-004	COVER, BEARING	1	
E-19	6	HP13-31141-003	PULLEY	1	
E-19	7	HPD1-31142-004	NUT, PULLEY LOCK	1	
E-19	8	HPD1-31145-004	BOLT, STUD, 6X68	4	
E-19	9	HPT0-31146-003	SCREW	4	
E-19	10	HP13-31147-003	SCREW	1	
E-19	11	HPT0-31147-003	SCREW-WASHER	3	
E-19	12	HP13-31148-003	SCREW, WAVE WASHER	4	
E-19	13	HPT0-31148-003	SCREW, WAVE WASHER	2	
E-19	14	HZY3-31630-003	GENERATOR ASSY., A.C.	1	
E-19	15	HZY3-31631-003	ROTOR ASSY.	1	
E-19	16	HZY3-31637-000	STAY, A.C. GENERATOR	1	
E-19	17	HZY3-31639-003	END COVER, RR.	1	
E-19	18	HZY3-31694-003	BUSH, INSULATION	1	
E-19	19	HZY3-31710-003	RECTIFIER ASSY.	1	
E-19	20	HZY3-31750-003	REGULATOR ASSY.	1	
E-19	21	HZX2-90002-000	BOLT, FLANGE, 10X90	1	
E-19	22	HZW5-90011-010	BOLT, SPECIAL ADJUSTER	1	
E-19	23	HZY3-90017-000	BOLT, FLANGE, 6X16	1	
E-19	24	HZY3-90055-000	BOLT, TENSIONER	1	
E-19	25	HZW5-90203-010	NUT, FLANGE, 8MM	1	
E-19	26	HPD1-90231-014	NUT-WASHER, 5MM	7	
E-19	27	HCO-94001-06080-0S	NUT, HEX., 6MM	1	

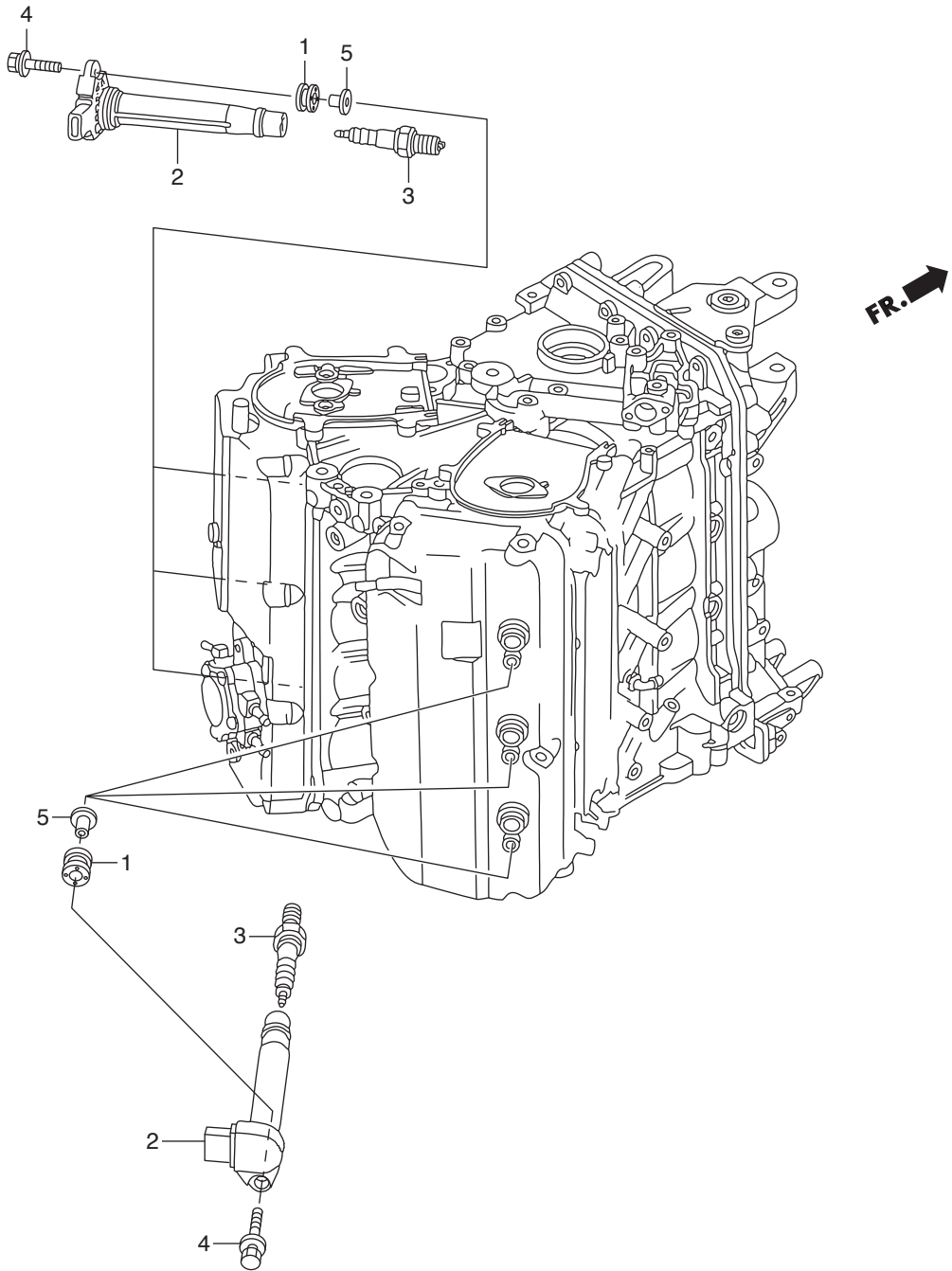



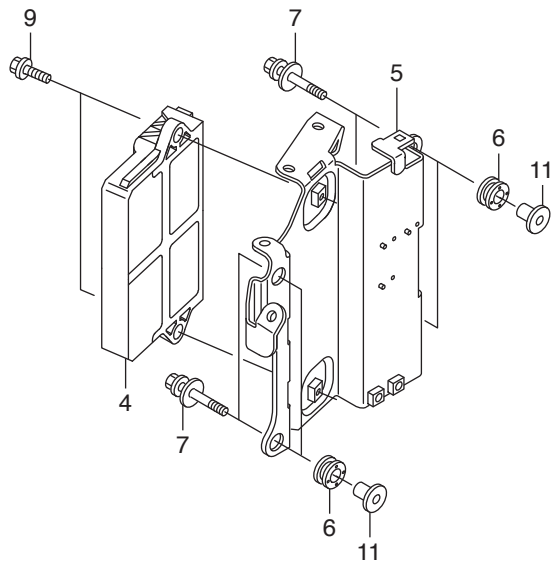
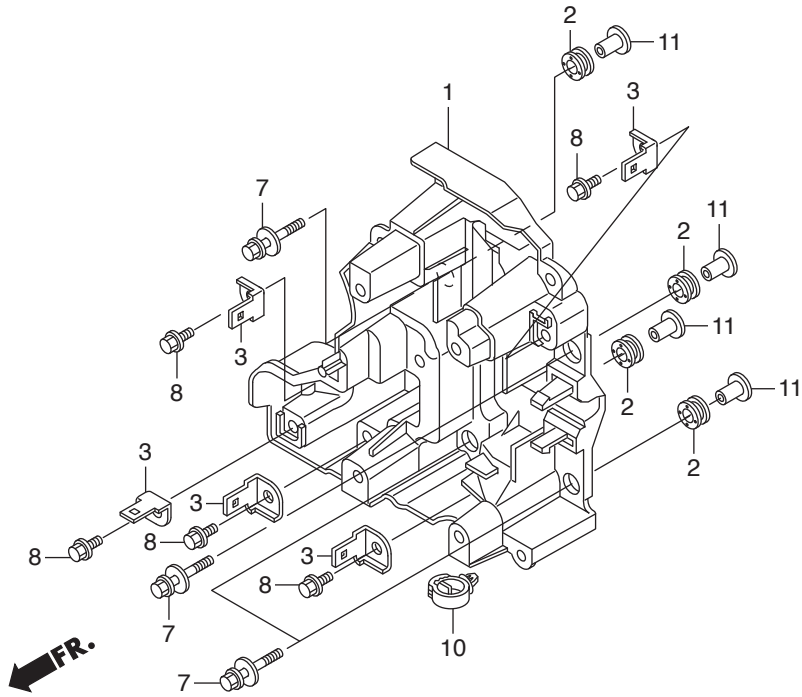



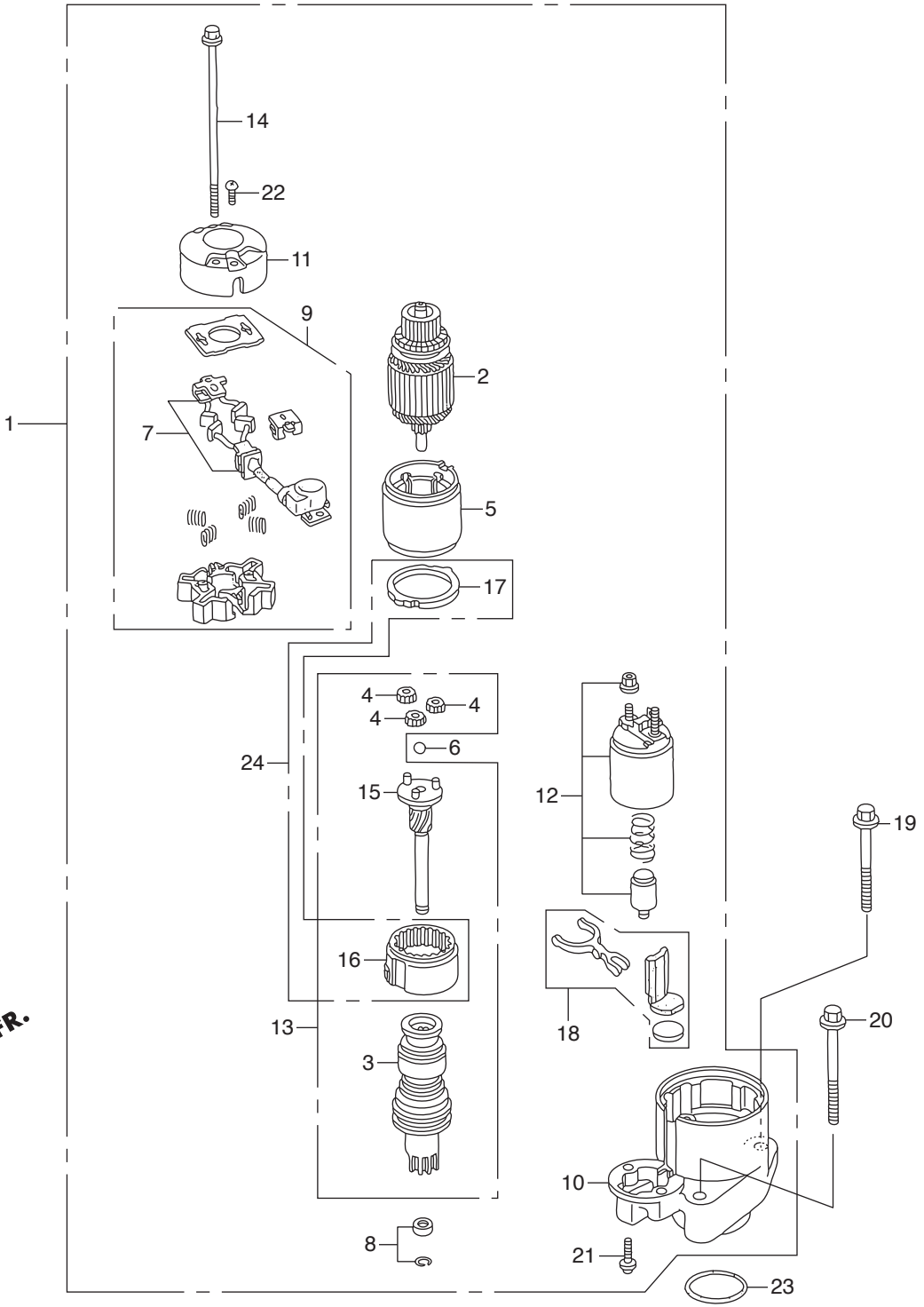

**FR.**



Ref.No.	Part No.	Description	Q' ty	Remarks	
			BF250A		
E-21	1	HZY3-31200-003	MOTOR ASSY., STARTER	1	
E-21	2	HP5A-31201-005	ROTOR COMP.	1	
E-21	3	HZY3-31207-003	CLUTCH COMP., OVERRUNNING	1	#~1003981 #~6000088
E-21		HZY9-31207-H01	CLUTCH COMP., OVERRUNNING	1	#1003982~ #6000089~
E-21	4	HPY3-31215-004	GEAR ASSY., PLANETARY	3	
E-21	5	HZY3-31216-003	YOKE COMP.	1	
E-21	6	HPY3-31218-004	BALL, STEEL	1	
E-21	7	HZW1-31226-004	BRUSH SET	1	#~1003981 #~6000088
E-21		HZY3-31226-003	BRUSH SET	1	#1003982~ #6000089~
E-21	8	HZW1-31229-004	STOPPER SET, SLEEVE	1	#~1003981 #~6000088
E-21		HZY9-31229-H01	STOPPER SET, SLEEVE	1	#1003982~ #6000089~
E-21	9	HZW1-31231-004	HOLDER COMP., BRUSH	1	#~1003981 #~6000088
E-21		HZY3-31232-003	HOLDER COMP., BRUSH	1	#1003982~ #6000089~
E-21	10	HZY3-31235-003	BRACKET, FR.	1	
E-21	11	HZY3-31236-003	BRACKET, RR.	1	
E-21	12	HZY3-31240-003	SWITCH ASSY., MAGNET	1	#~1003981 #~6000088
E-21		HZY3-31241-003	SWITCH ASSY., MAGNET	1	#1003982~ #6000089~
E-21	13	HZY3-31242-003	SHAFT ASSY., CLUTCH	1	#~1003981 #~6000088
E-21		HZY3-31243-003	SHAFT ASSY., CLUTCH	1	#1003982~ #6000089~
E-21	14	HP5A-31243-005	BOLT A, THROUGH	2	
E-21	15	HZY3-31246-003	SHAFT ASSY., GEAR	1	#~1003981 #~6000088
E-21		HZY9-31246-H01	SHAFT ASSY., GEAR	1	#1003982~ #6000089~
E-21	16	HZY3-31247-003	GEAR ASSY., INTERNAL	1	#~1003981 #~6000088
E-21	17	HZY3-31249-003	RPACKING	1	#~1003981 #~6000088
E-21	18	HZY3-31250-003	LEVER SET	1	
E-21	19	HZY3-90002-000	BOLT, FLANGE, 10X90	1	
E-21	20	HZY3-90003-000	BOLT, FLANGE, 10X110	1	
E-21	21	HZW1-90106-004	SCREW, PAN, 6X22(SPECIAL)	2	#~1003981 #~6000088
E-21		HZY9-31226-H01	SCREW, PAN, 6X22	2	#1003982~ #6000089~

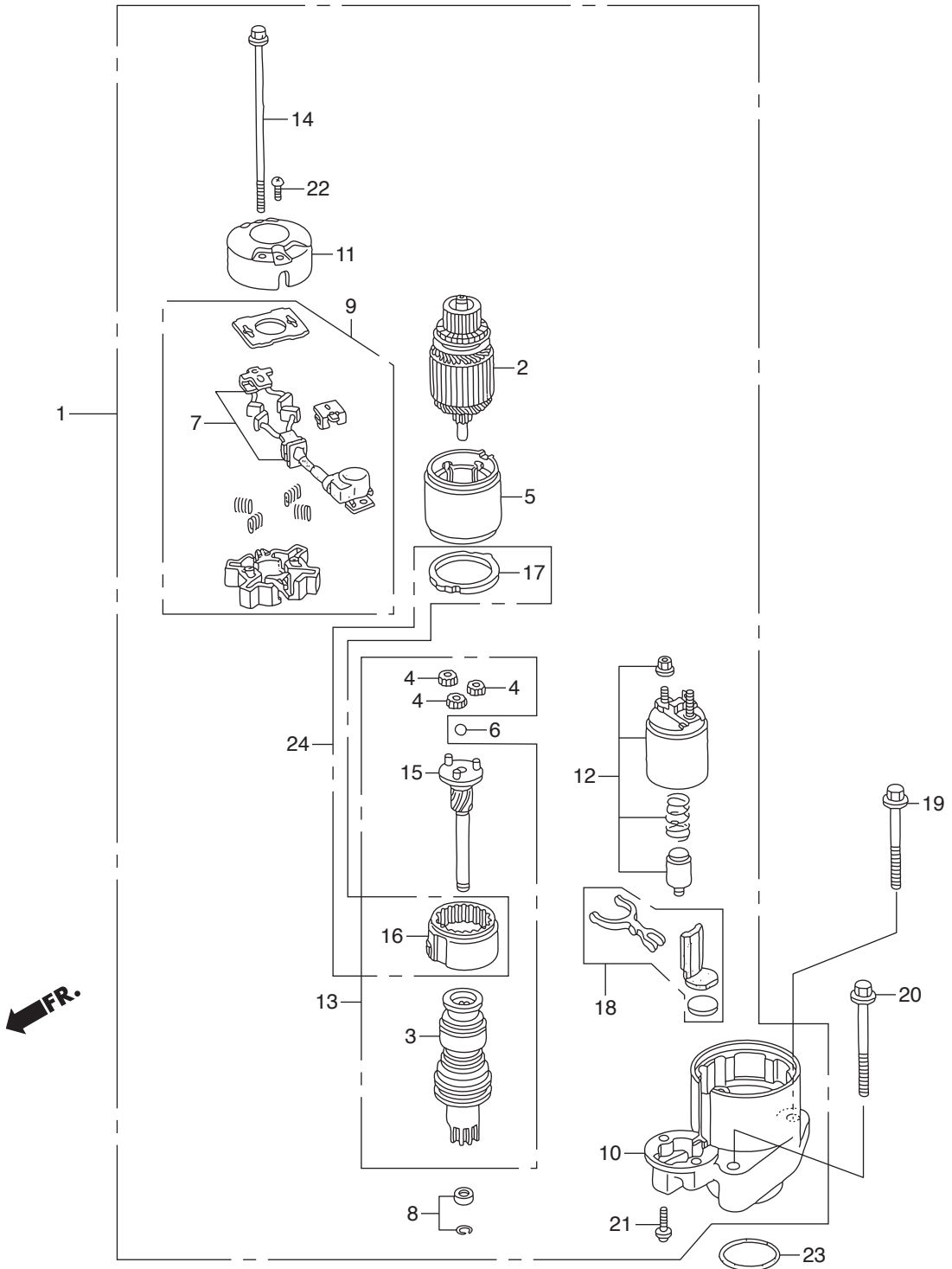



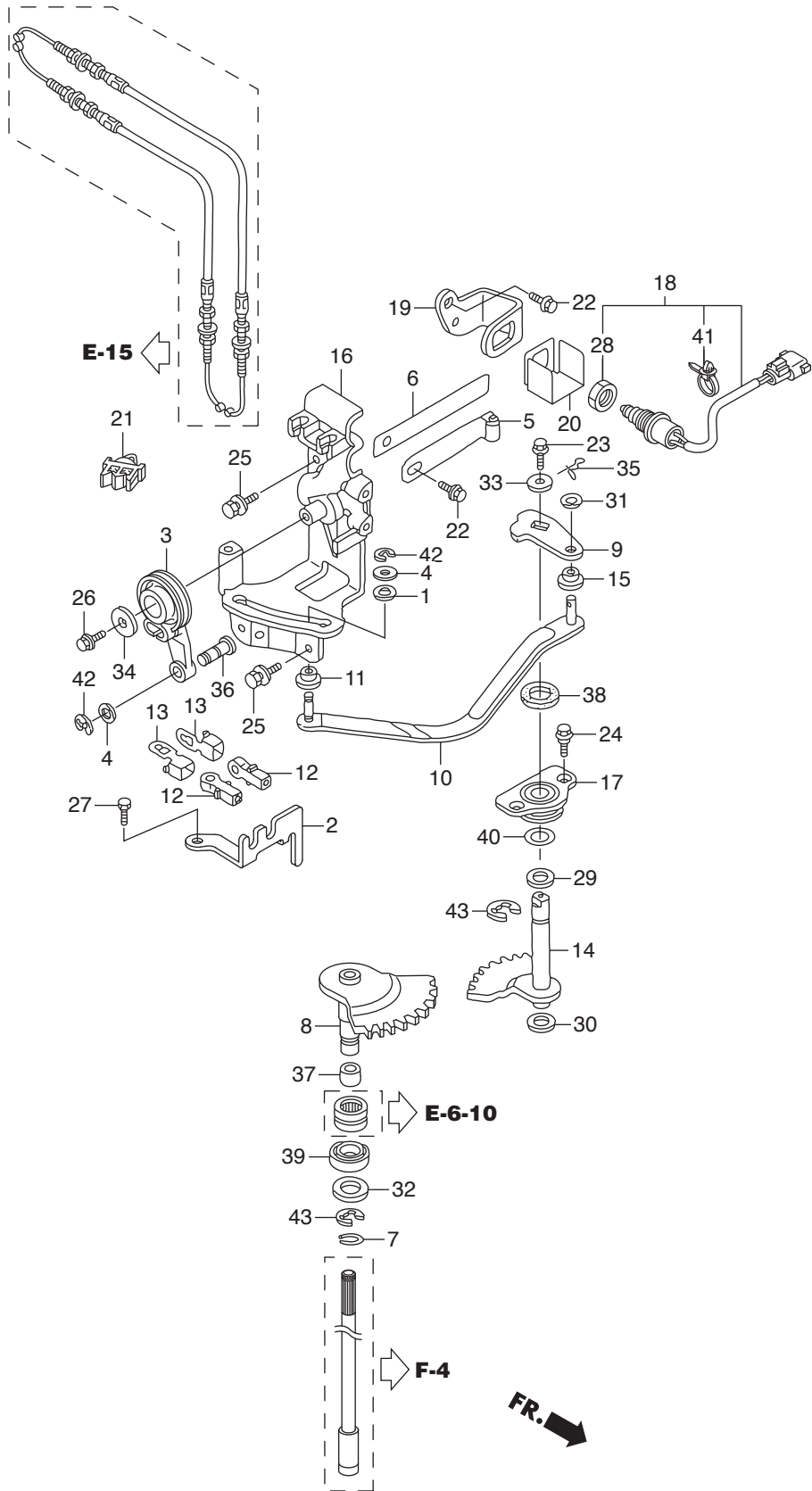

Ref.No.	Part No.	Description	Q' ty	Remarks	
			BF250A		
F-2	1	HKN5-17224-670	WASHER, AIR CLEANER COVER	1	SETTING
F-2	2	HZY3-17877-000	PLATE, REMOTE CONTROL CABLE	1	
F-2	3	HZY3-17931-000	ARM, THROTTLE	1	
F-2	4	H921-17936-000	WASHER, PIVOT	2	
F-2	5	HZW1-24210-010	SPRING COMP., CLICK	1	
F-2	6	HZY3-24221-000	SPRING, CLICK ASSIST	1	
F-2	7	HZW1-24327-000	RING, STOPPER	1	
F-2	8	HZY3-24610-A00	SHAFT COMP., SHIFT(A)	1	
F-2	9	HZY3-24612-010	ARM, SHIFT	1	
F-2	10	HZY3-24613-000	ROD, LINK	1	
F-2	11	HZY3-24617-000	COLLAR, SHIFT SLIDER	1	
F-2	12	HZY3-24618-000	PIVOT, SHIFT	2	
F-2	13	HZY3-24619-000	PLATE, LOCK	2	
F-2	14	HZY3-24620-000	SHAFT COMP., SHIFT(B)	1	
F-2	15	HZY3-24623-000	BUSH, SHIFT ARM	1	
F-2	16	HZY3-24628-000	BRACKET, SHIFT LINK	1	
F-2	17	HZW1-24629-000	HOLDER, SEAL	1	
F-2	18	HZX2-35470-013	SWITCH ASSY., NEUTRAL	1	
F-2	19	HZY3-35476-010	BRACKET, NEUTRAL SWITCH	1	
F-2	20	HZY3-35477-000	COVER, NEUTRAL SWITCH	1	
F-2	21	HS0X-46392-A01	CLIP, BRAKE PIPE	1	
F-2	22	HZW9-90011-000	BOLT, FLANGE, 6X14(CT200)	2	
F-2	23	HZY3-90017-000	BOLT, FLANGE, 6X16	1	
F-2	24	HZW5-90023-000	BOLT, FLANGE, 6X11	2	
F-2	25	HZX2-90101-C00	BOLT-WASHER, 6X16	3	
F-2	26	HZW9-90102-000	BOLT, FLANGE, 6X12	1	
F-2	27	HZV4-90127-000	BOLT, HEX., 6X16	1	
F-2	28	HZV5-90302-003	NUT, HEX., 20MM	1	
F-2	29	HHA0-90402-000	WASHER, THRUST, 14MM	1	

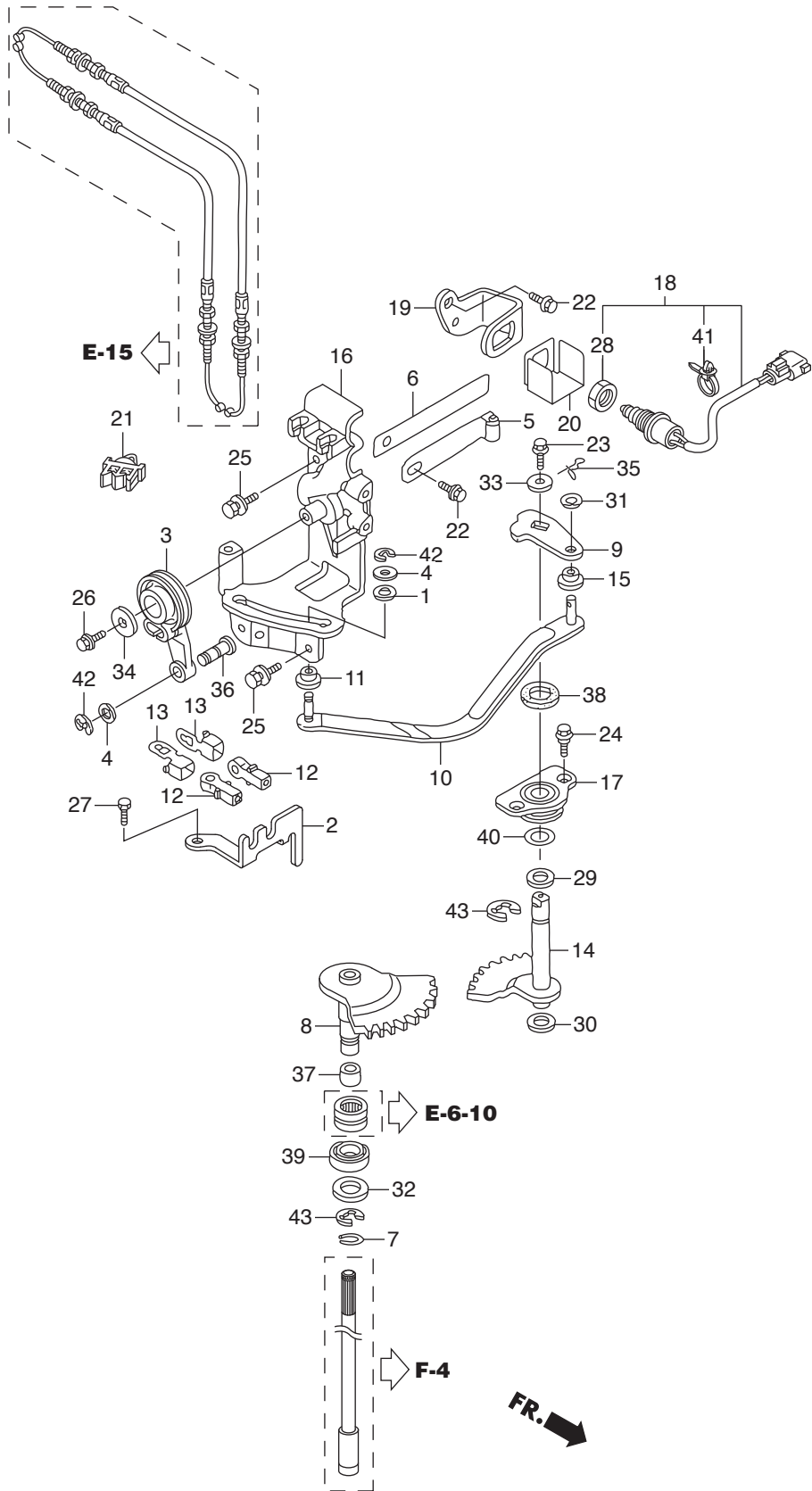



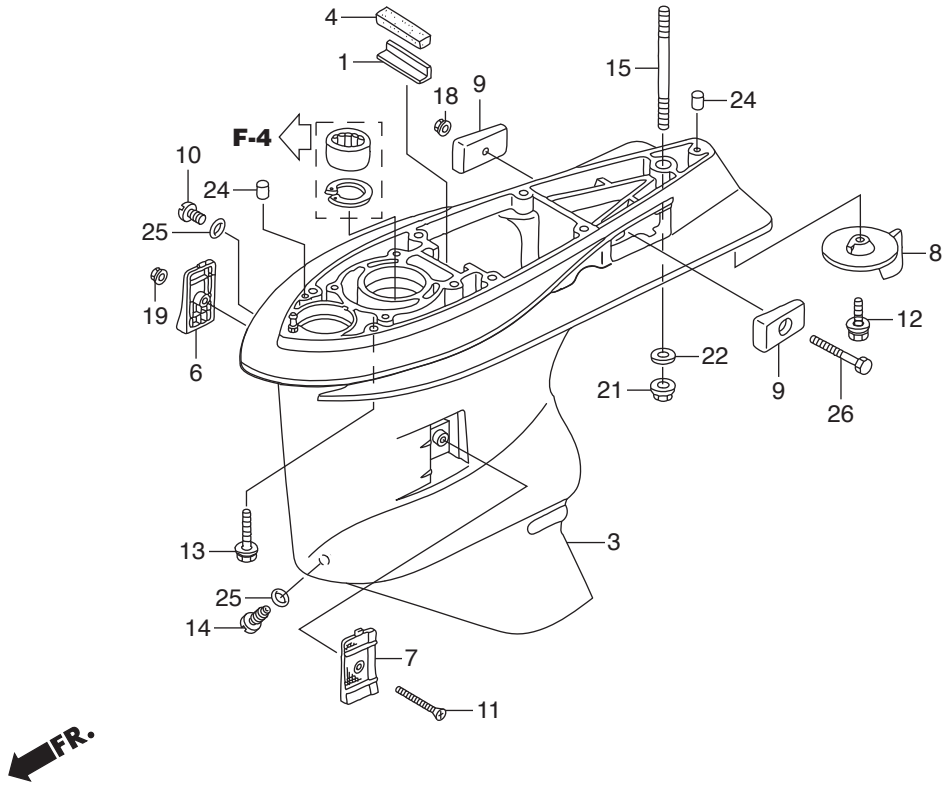





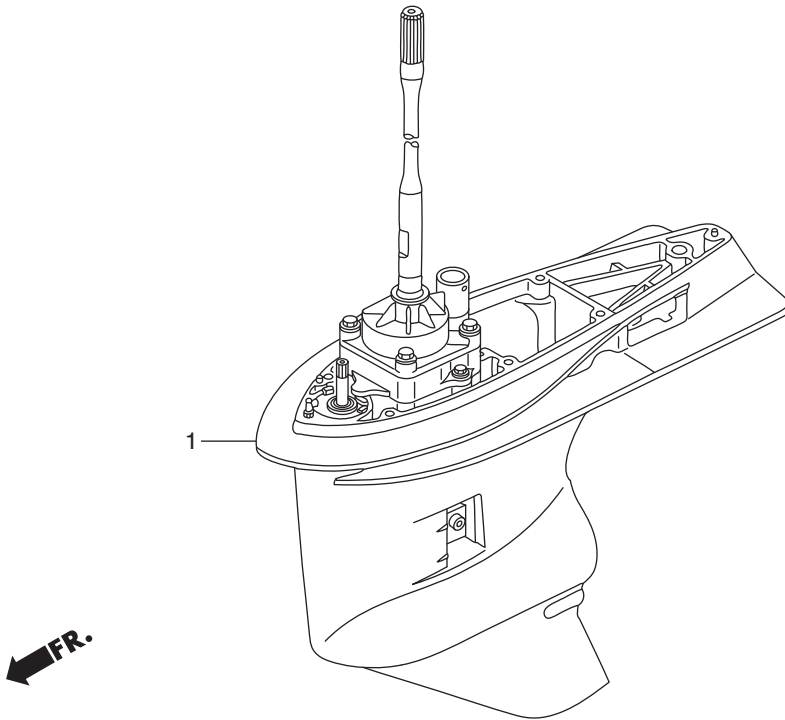



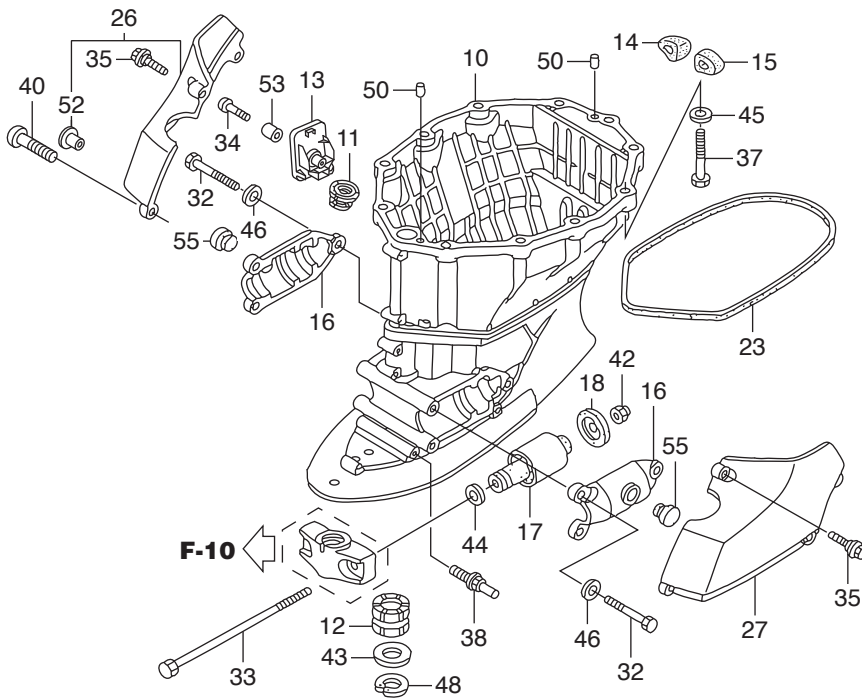
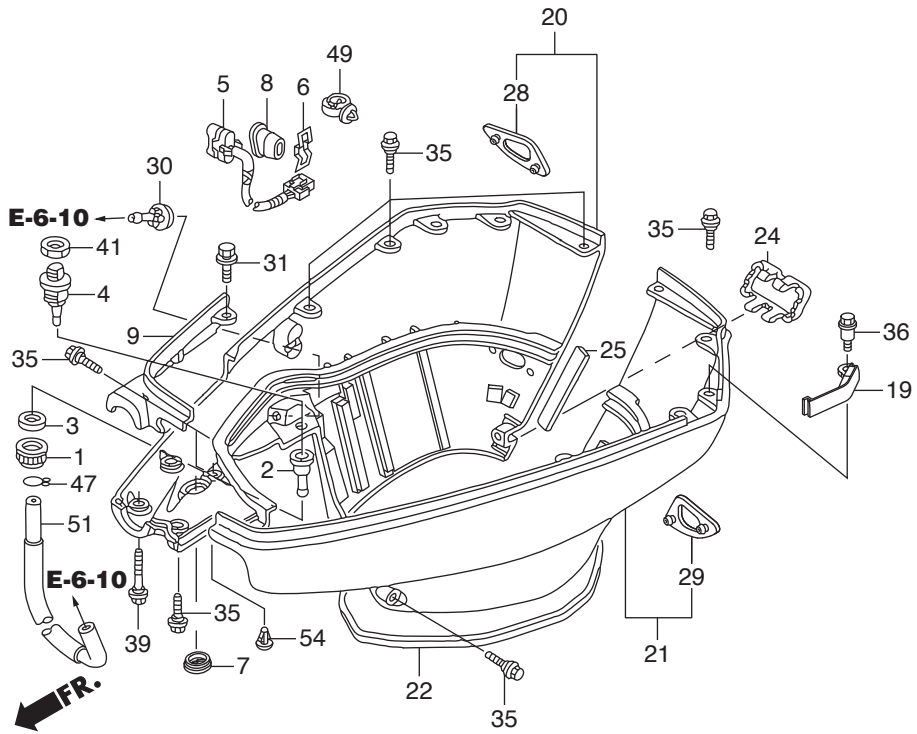

Ref.No.	Part No.	Description	Q' ty	Remarks	
			BF250A		
F-3-20	1	HZY3-19270-000	NUT, WATER MOUTH	1	
F-3-20	2	HZY3-19271-000	JOINT, WATER HOSE	1	
F-3-20	3	HZY3-19272-000	SEAT, WATER MOUTH	1	
F-3-20	4	HZY3-19289-000	CAP, WATER JOINT	1	
F-3-20	5	HZY3-35640-013	SWITCH ASSY., POWER TILT	1	
F-3-20	6	HZY3-35645-000	STAY, POWER TILT SWITCH	1	
F-3-20	7	HZV5-40107-000	GROMMET, UNDER CASE(C)	1	
F-3-20	8	HZY3-40114-010	GROMMET, POWER TILT SWITCH	1	
F-3-20	9	HZY3-40151-000ZC	COVER, FR. SEPARATE	1	*T107* BAY BLUE
F-3-20	10	HZY3-40201-612ZC	CASE, EXTENSION	1	*T107* BAY BLUE
F-3-20	11	HZW1-40209-000	RUBBER, DRAIN PLUG	1	
F-3-20	12	HZY3-40210-610	BUSH COMP., VERTICAL SHAFT	1	
F-3-20	13	HZY3-40212-611ZC	COVER, DRAIN PLUG(XL)	1	*T107* BAY BLUE
F-3-20	14	HZY3-40225-010	SEAL, R. IDOL PORT	1	
F-3-20	15	HZY3-40226-010	SEAL, L. IDOL PORT	1	
F-3-20	16	HZY3-50111-020	HOUSING, LOWER MOUNTING	2	
F-3-20	17	HZY3-50155-000	MOUNT COMP., LOWER RUBBER	2	
F-3-20	18	HZY3-50157-010	STOPPER, LOWER MOUNT	2	
F-3-20	19	HZY3-63347-C00	COVER, PLUG MAINTENANCE	1	
F-3-20	20	HZX2-63710-C00ZB	COVER COMP., R. UNDER ENGINE	1	*T107* BAY BLUE
F-3-20	21	HZX2-63715-C00ZB	COVER COMP., L. UNDER ENGINE	1	*T107* BAY BLUE
F-3-20	22	HZY3-63718-000	SEAL A, COVER UNDER	1	
F-3-20	23	HZX2-63719-C00	SEAL B, COVER UNDER	1	
F-3-20	24	HZY3-63722-010ZC	CAP, UNDER COVER	1	*T107* BAY BLUE
F-3-20	25	HZY3-63728-000	SEAL C, UNDER COVER	1	
F-3-20	26	HZY3-63731-A12ZC	COVER, R. LOWER MOUNTING	1	*T107* BAY BLUE
F-3-20	27	HZY3-63736-A12ZC	COVER, L. LOWER MOUNTING	1	*T107* BAY BLUE
F-3-20	28	HZY3-63751-C00	GROMMET, R. IDLE PORT	1	
F-3-20	29	HZY3-63756-C00	GROMMET, L. IDLE PORT	1	

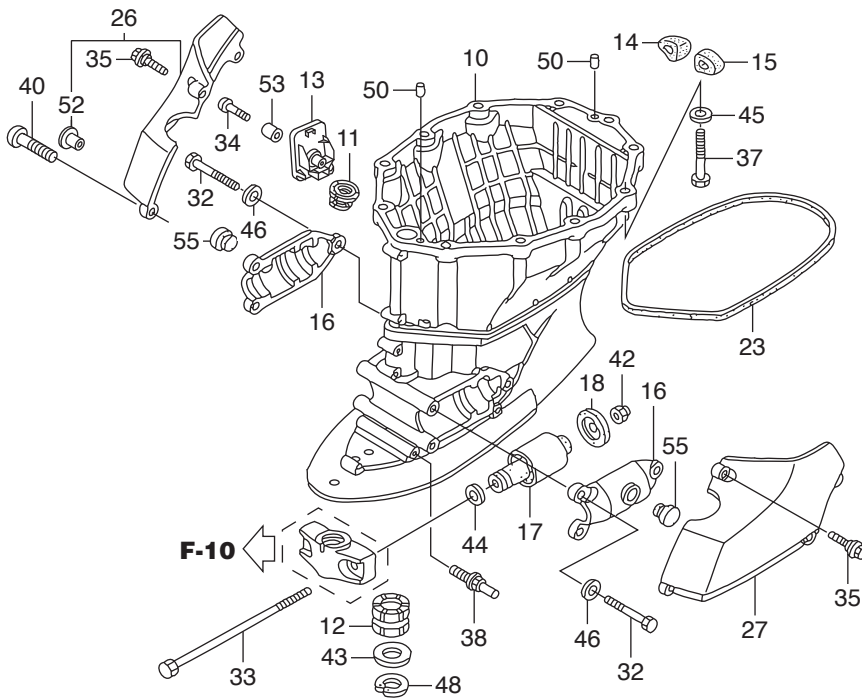
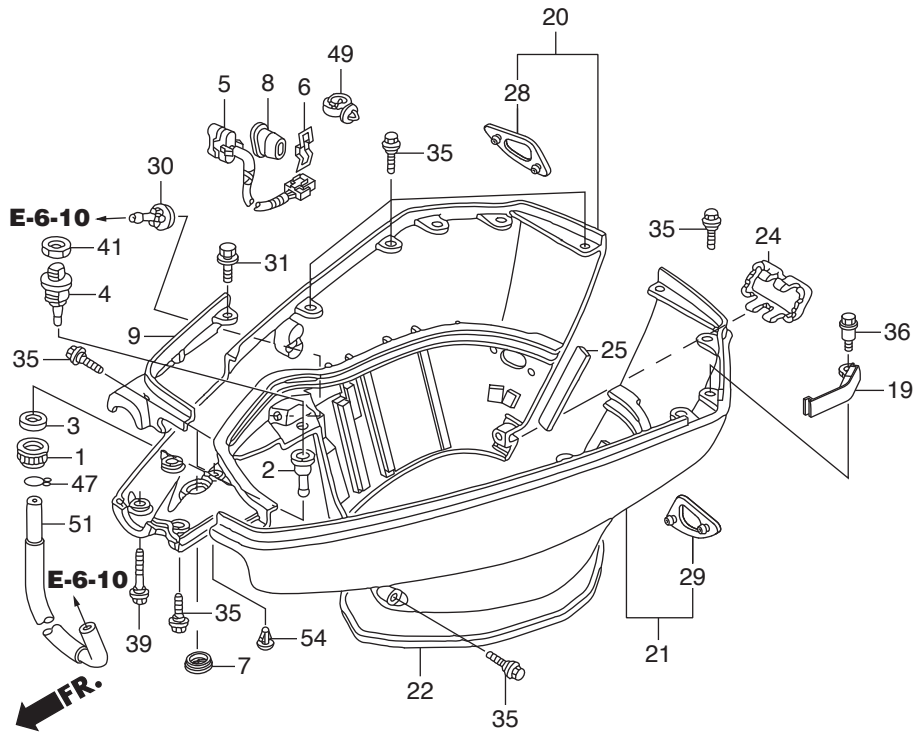

Ref.No.		Part No.	Description	Q' ty	Remarks
				BF250A	
F-3-20	30	HZV5-82873-003	GROMMET, WATER CHECK	1	
F-3-20	31	HZX2-90102-C00	BOLT-WASHER, 6X25	2	
F-3-20	32	HZY3-90102-A00	BOLT, HEX., 10X35	6	
F-3-20	33	HZY3-90105-010	BOLT, HEX., 14X180	2	
F-3-20	34	HZV5-90110-000	SCREW, SPECIAL, 6X35	1	
F-3-20	35	HZY3-90111-000	BOLT, SPECIAL, 6X17	26	
F-3-20	36	HZY3-90113-C00	BOLT, SPECIAL, 6X22	1	
F-3-20	37	HZY3-90122-000	BOLT, HEX., 12X50	11	
F-3-20	38	HZY3-90129-A00	BOLT, SPECIAL, 6X12	2	
F-3-20	39	HZY3-90132-000	BOLT, SPECIAL, 6X37	2	
F-3-20	40	HCO-93500-06025-4J	SCREW, PAN, 6X25	1	
F-3-20	41	H921-90302-000	NUT, HEX., 16MM	1	
F-3-20	42	HZY3-90302-000	NUT, SELF-LOCK, 14MM	2	
F-3-20	43	HZY3-90503-610	WASHER, 30MM	1	
F-3-20	44	HZY3-90511-000	WASHER, PLAIN, 14MM	2	
F-3-20	45	HZV5-90559-000	WASHER, PLAIN, 12MM	11	
F-3-20	46	HZV5-90563-000	WASHER, PLAIN, 10MM	6	
F-3-20	47	HZV4-90605-000	CLIP, TUBE(B12.5)	1	
F-3-20	48	HZY3-90652-000	CIRCLIP, INTERNAL, 43	1	
F-3-20	49	HSA0-90683-003	CLIP, WIRE HARNESS, 25MM	1	
F-3-20	50	HZV5-90756-000	DOWEL PIN, 6X10	2	
F-3-20	51	HZY3-91451-000	TUBE, WATER JOINT	1	
F-3-20	52	HZY6-91553-000	COLLAR, DISTANCE, 6.5X9X5	1	
F-3-20	53	HZV5-91563-000	COLLAR, DISTANCE, 6X10.5X25	1	
F-3-20	54	HZY3-91651-003	PLUG, HOLE, 5MM	1	
F-3-20	55	HCO-95011-63000	RUBBER C, STAND STOPPER	2	

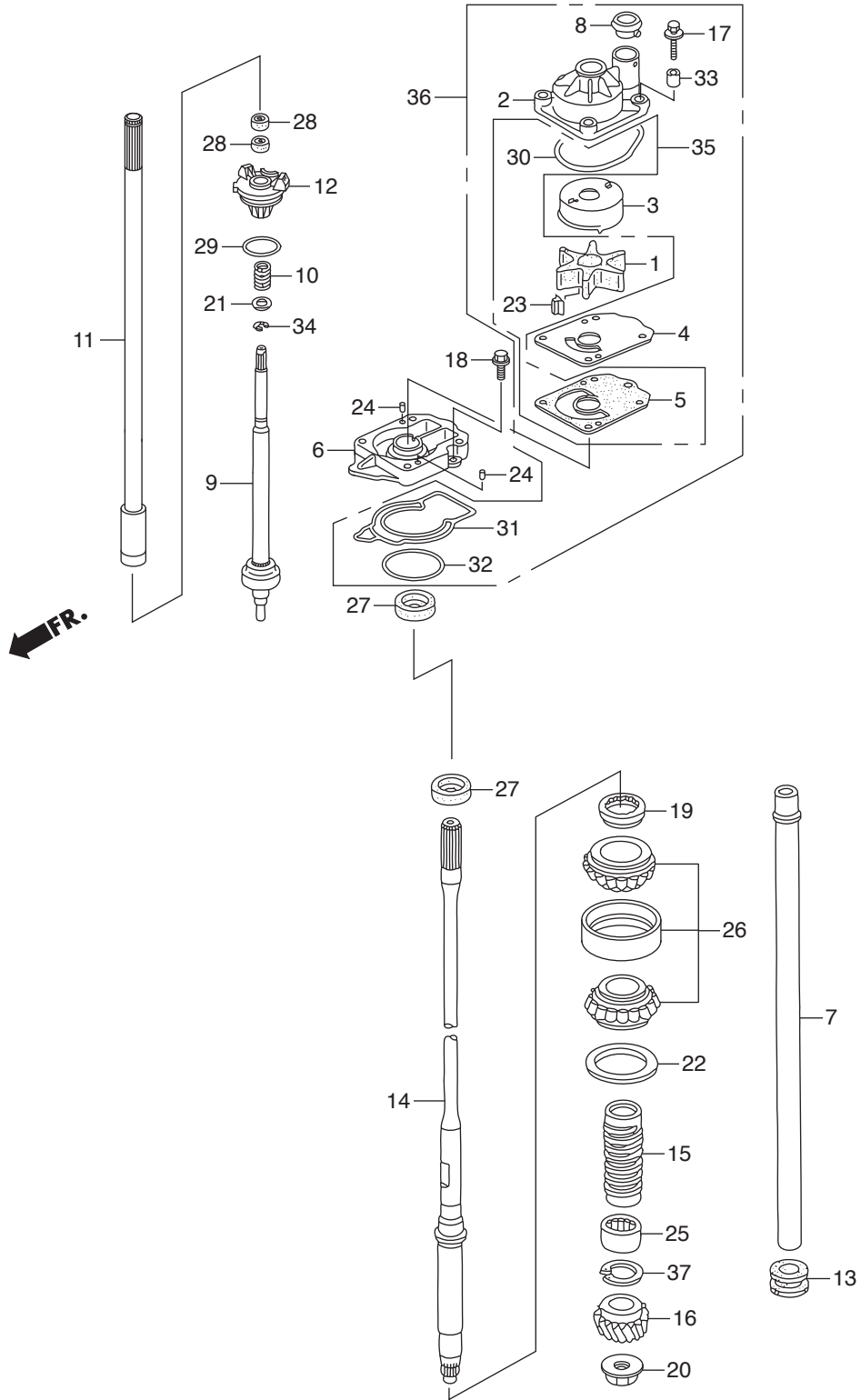



Ref.No.	Part No.	Description	Q' ty	Remarks	
			BF250A		
F-4	1	HZY3-19210-003	IMPELLER, PUMP	1	
F-4	2	HZY3-19221-010	HOUSING, IMPELLER	1	
F-4	3	HZY3-19223-000	LINER, PUMP	1	
F-4	4	HZY3-19231-000	COVER, IMPELLER	1	
F-4	5	HZX2-19234-C00	GASKET B, IMPELLER	1	
F-4	6	HZX2-19241-C00	HOUSING, WATER PUMP	1	
F-4	7	HZY3-19251-611	TUBE, WATER(XL)	1	
F-4	8	HZY3-19253-000	RING, WATER TUBE SEAL	1	
F-4	9	HZY3-24310-C00	ROD COMP., SHIFT	1	
F-4	10	HZY3-24318-000	SPRING, SHIFT ROD	1	
F-4	11	HZY6-24320-610	ROD COMP. A, SHIFT(XL)	1	
F-4	12	HZW1-24343-B02	HOLDER, SHIFT ROD	1	
F-4	13	HZY3-40204-000	GROMMET, EXTENSION CASE	1	
F-4	14	HZX2-41112-C10	SHAFT, VERTICAL(XL)	1	
F-4	15	HZY3-41116-000	SLINGER, OIL	1	
F-4	16	HZX2-41131-C00	GEAR, PINION	1	
F-4	17	HZX2-90105-C00	BOLT, WASHER, 8X60	4	
F-4	18	HHW1-90215-671	BOLT, FLANGE, 6X16	1	
F-4	19	HZX2-90301-C00	NUT, LOCK, 68MM	1	
F-4	20	HZX2-90303-C00	NUT, HEX., 18MM	1	
F-4	21	H723-90472-000	WASHER, PLAIN, 12MM	1	
F-4	22	HZX2-90518-C00	SHIM A, GEAR(0.10)	1	
F-4		HZX2-90519-C00	SHIM B, GEAR(0.15)	1	
F-4		HZX2-90520-C00	SHIM C, GEAR(0.30)	1	
F-4		HZX2-90521-C00	SHIM D, GEAR(0.50)	1	
F-4	23	HZY3-90752-003	KEY, WOODRUFF	1	
F-4	24	HZV5-90756-000	DOWEL PIN, 6X10	2	
F-4	25	HZX2-91053-C01	BEARING, NEEDLE, 30.5X47X37	1	
F-4	26	HZX2-91056-C01	BEARING, TAPER ROLLER,	1	32X66X49

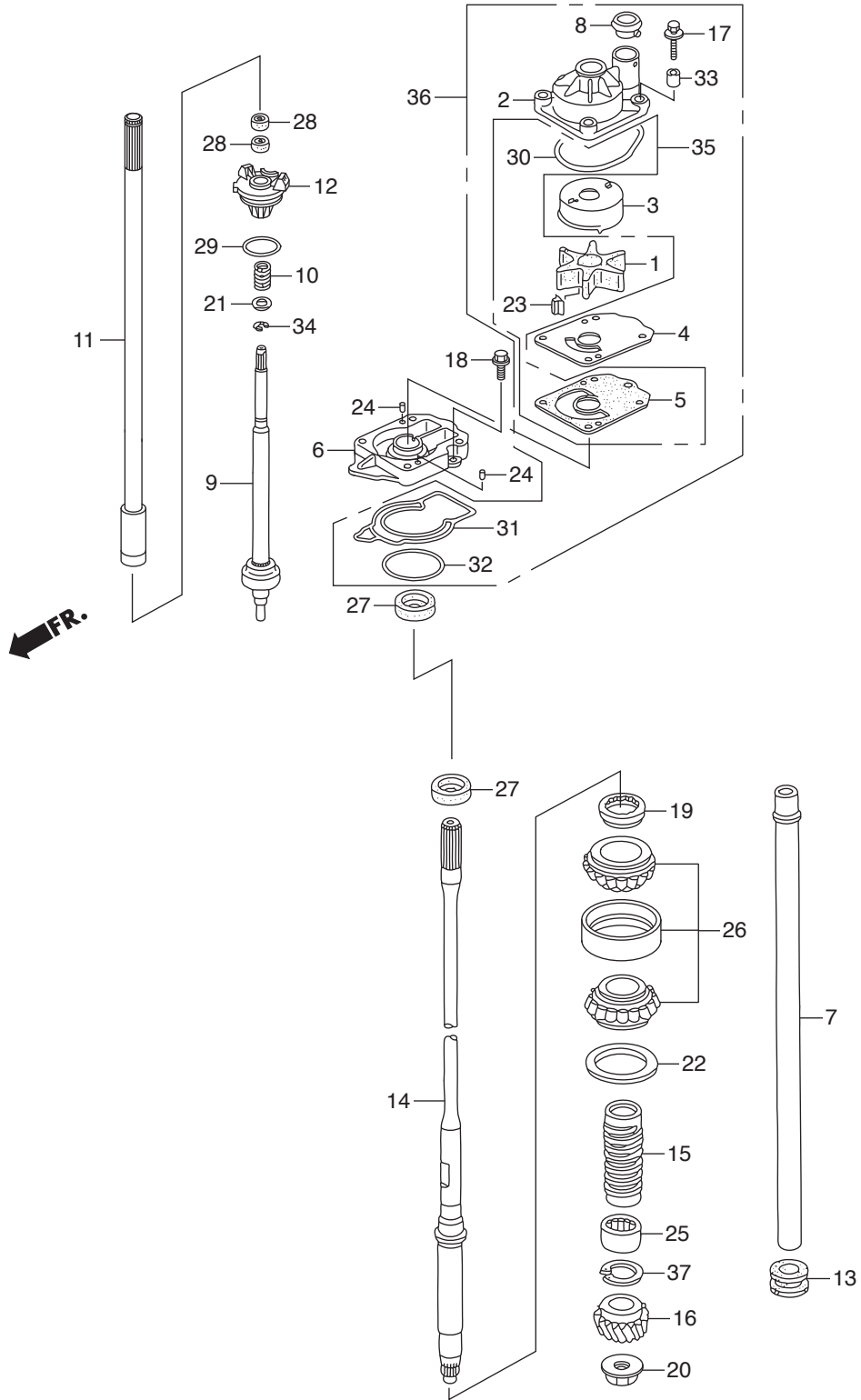



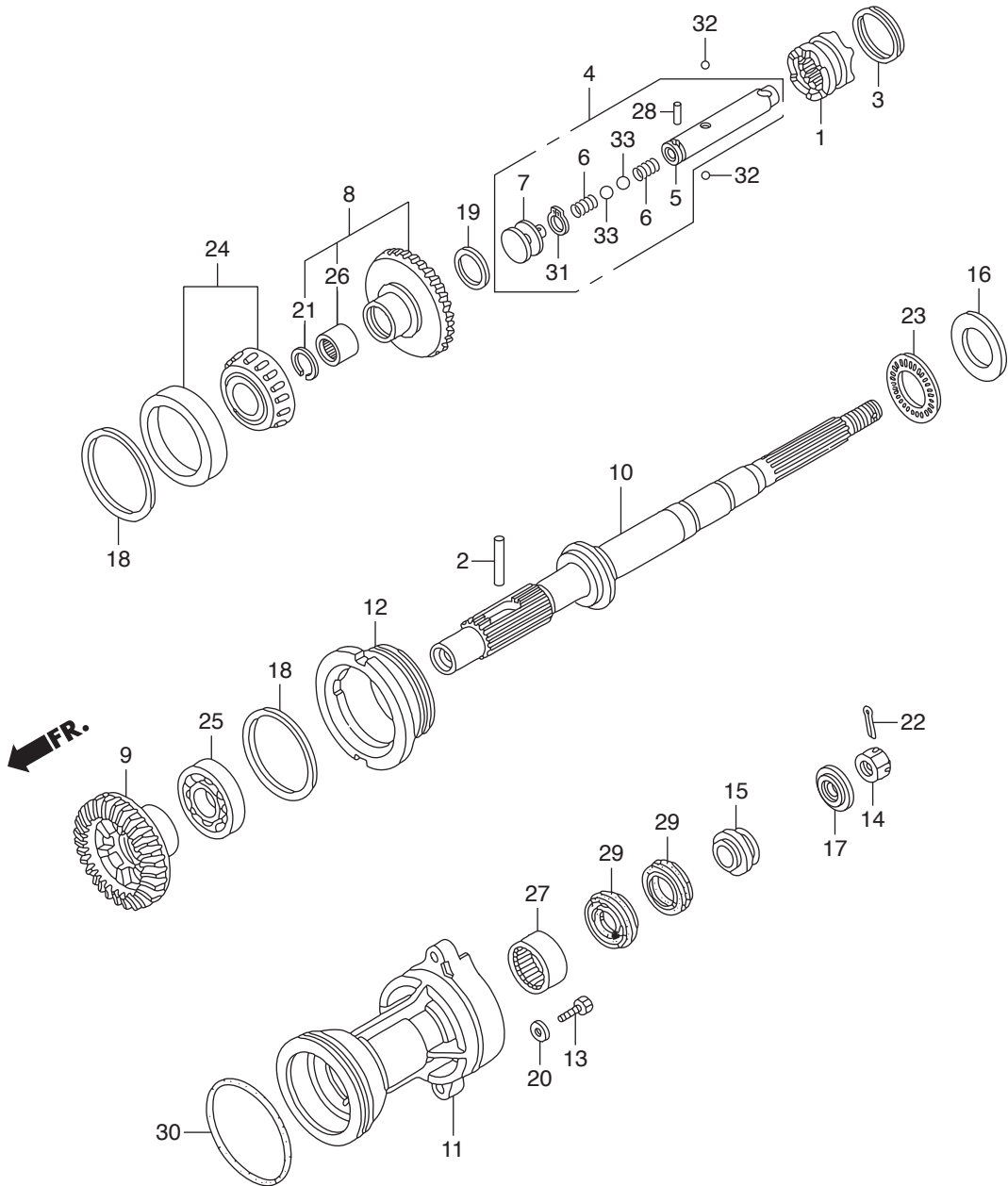

Ref.No.	Part No.	Description	Q' ty	Remarks	
			BF250A		
F-5	1	HZX2-24101-C00	SHIFTER, CLUTCH	1	
F-5	2	HZY3-24102-000	PIN, SHIFTER, 8X50	1	
F-5	3	HZY3-24103-000	RING, CROSS PIN	1	
F-5	4	HZY3-24113-A01	SLIDER COMP., SHIFT	1	
F-5	5	HZY3-24122-A01	SLIDER, SHIFT	1	
F-5	6	HZY3-24123-000	SPRING, SHIFT	2	
F-5	7	HZY3-24124-310	PLATE, SHIFT	1	
F-5	8	HZX2-41140-C00	GEAR COMP., BEVEL(FORWARD)	1	(24T)
F-5	9	HZX2-41151-C00	GEAR, BEVEL(REVERSE)(24T)	1	
F-5	10	HZX2-41161-C00	SHAFT, PROPELLER	1	
F-5	11	HZX2-41201-C00ZC	HOLDER, PROPELLER SHAFT	1	*T107* BAY BLUE
F-5	12	HZX2-41202-C00	HOLDER, BEARING	1	
F-5	13	HZY3-90123-000	BOLT, HEX., 12X45	2	
F-5	14	HZW1-90301-B00	NUT, CASTLE, 18MM	1	
F-5	15	HZY3-90506-000	WASHER, PROPELLER THRUST	1	
F-5	16	HZW5-90509-711	WASHER, THRUST BEARING	1	
F-5	17	HZY3-90512-000	WASHER, PROPELLER	1	
F-5	18	HZX2-90528-C00	SHIM A, BEVEL(0.10)	2	
F-5		HZX2-90529-C00	SHIM B, BEVEL(0.15)	2	
F-5		HZX2-90530-C00	SHIM C, BEVEL(0.30)	2	
F-5		HZX2-90531-C00	SHIM D, BEVEL(0.50)	2	
F-5	19	HZY3-90548-000	SHIM A, THRUST(2.75)	1	
F-5		HZY3-90549-000	SHIM B, THRUST(2.80)	1	
F-5		HZY3-90550-000	SHIM C, THRUST(2.85)	1	
F-5		HZY3-90551-000	SHIM D, THRUST(2.90)	1	
F-5		HZY3-90552-000	SHIM E, THRUST(2.95)	1	
F-5		HZY3-90553-000	SHIM F, THRUST(3.00)	1	
F-5		HZY3-90554-000	SHIM G, THRUST(3.05)	1	
F-5		HZY3-90555-000	SHIM H, THRUST(3.10)	1	

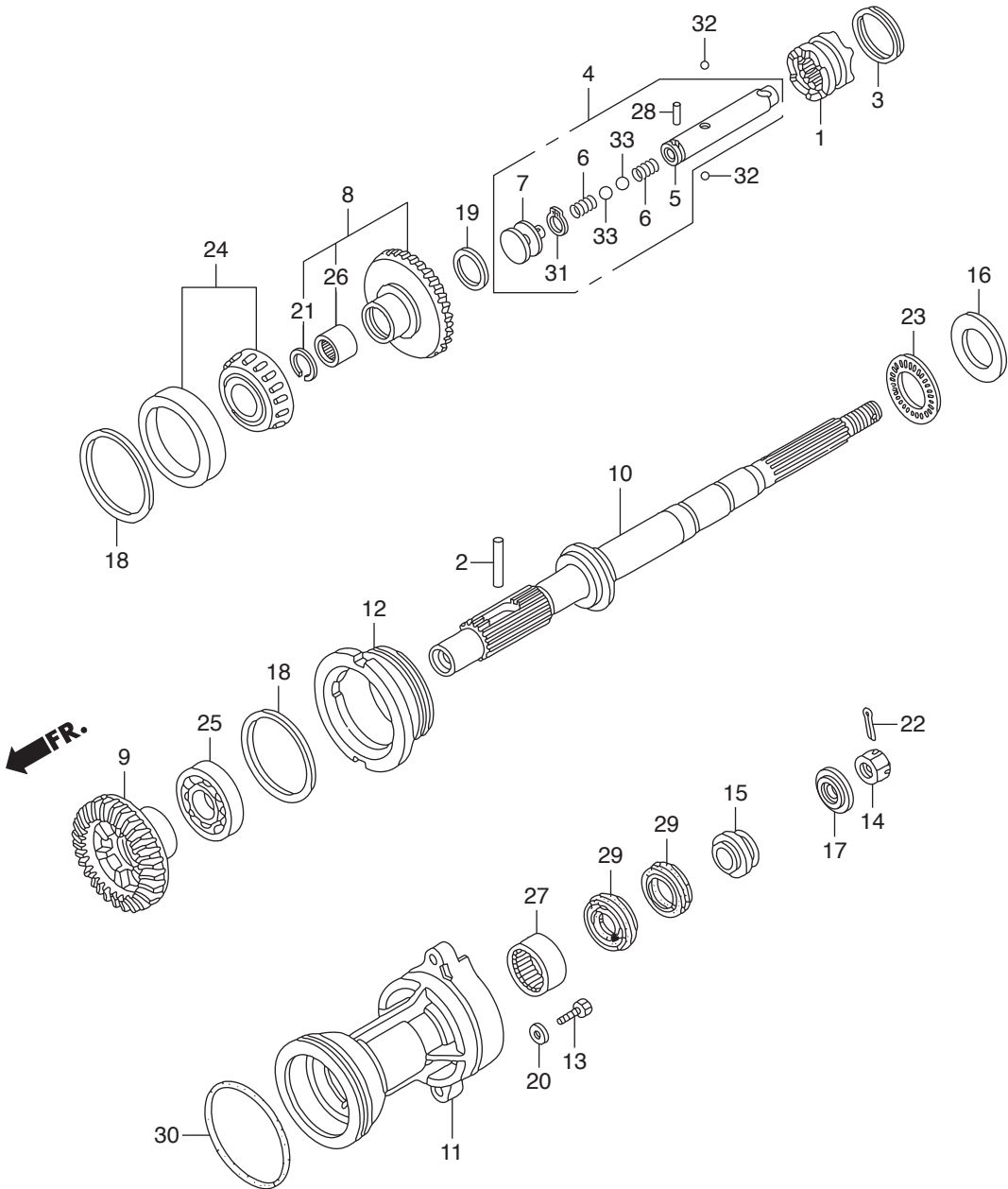



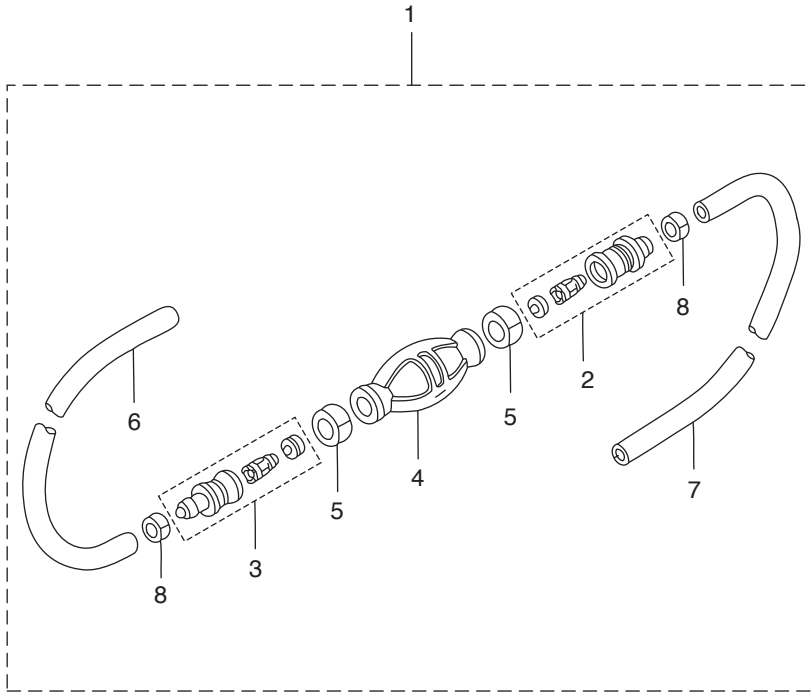





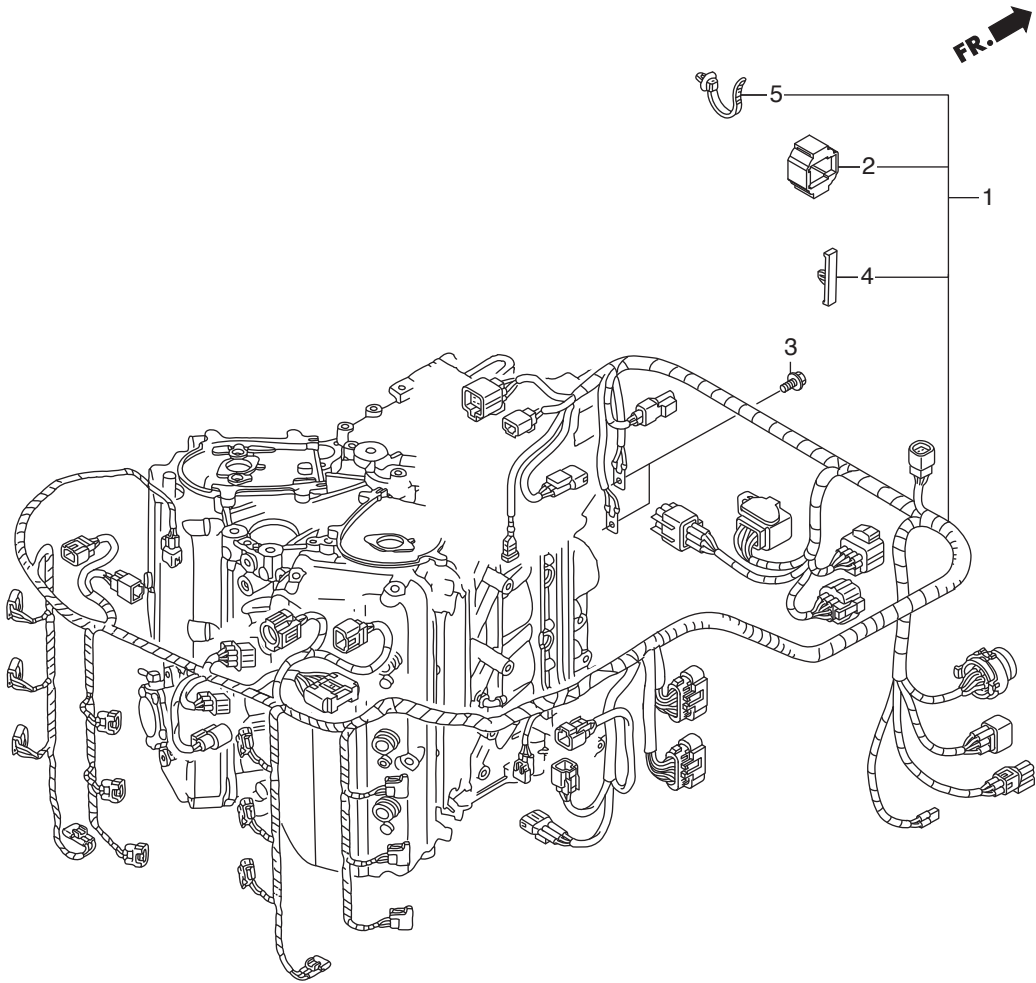



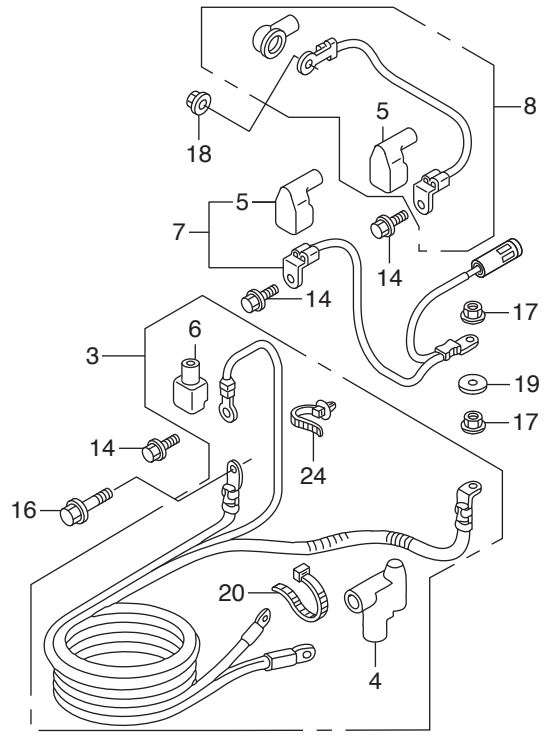
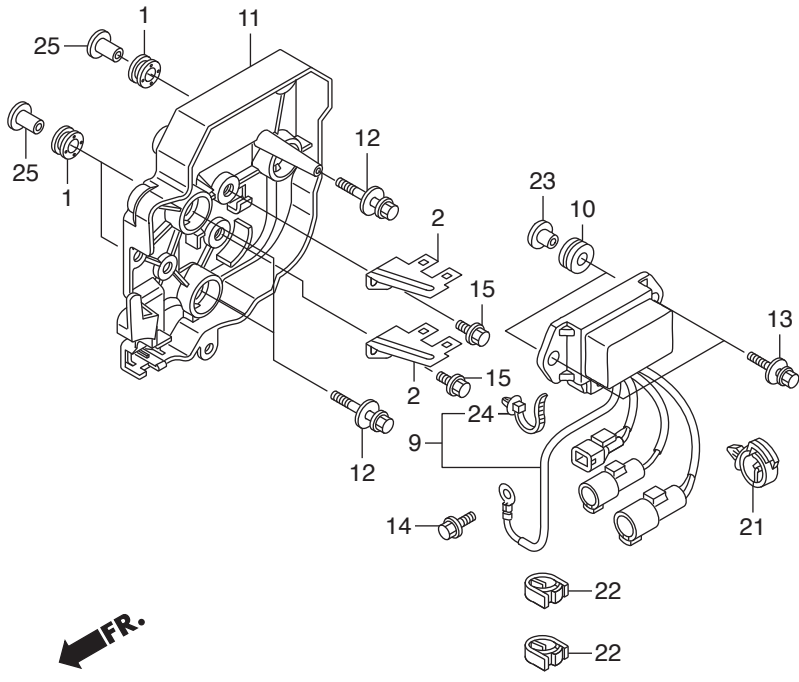

Ref.No.	Part No.	Description	Q' ty	Remarks	
			BF250A		
F-7-10	1	HZY9-30419-003	GROMMET, ELECTRONIC PARTS CASE	3	
F-7-10	2	HZY9-32103-000	BRACKET C, COUPLER	2	
F-7-10	3	HZX2-32410-000	CABLE ASSY., STARTER	1	
F-7-10	4	HZY3-32411-003	COVER, STARTER TERMINAL	1	
F-7-10	5	HZX2-32414-300	COVER B, TERMINAL(L)	2	
F-7-10	6	HZY6-32414-640	COVER B, TERMINAL	1	
F-7-10	7	HZX2-32415-000	CABLE ASSY., POWER TILT RELAY	1	
F-7-10	8	HZX2-32435-000	CORD, A.C. GENERATOR	1	
F-7-10	9	HZX2-38550-003	RELAY ASSY., POWER TILT	1	
F-7-10	10	HZW1-38551-000	GROMMET, RELAY	2	
F-7-10	11	HZX2-38552-000	CASE, POWER TILT RELAY	1	
F-7-10	12	HZW2-90003-000	BOLT-WASHER, 6X27(CT200)	3	
F-7-10	13	HZW1-90013-000	BOLT-WASHER, 6X25	2	
F-7-10	14	HZW9-90013-000	BOLT, FLANGE, 6X12	4	
F-7-10	15	HZW9-90014-000	BOLT, FLANGE, 6X10	2	
F-7-10	16	HZY3-90107-000	BOLT, FLANGE, 8X18	1	
F-7-10	17	HZW1-90203-000	NUT-WASHER, 8MM	2	
F-7-10	18	HZY3-90304-000	NUT-WASHER, 6MM	1	
F-7-10	19	HZY3-90405-000	WASHER, PLAIN, 8MM	1	
F-7-10	20	HSB2-90620-003	BAND, WIRE HARNESS	1	
F-7-10	21	H763-90681-A01	CLIP, WIRE HARNESS	1	
F-7-10	22	HZX2-90683-003	CLIP, WIRE HARNESS	2	
F-7-10	23	HZZ5-91501-000	COLLAR, MOUNTING(6MM)	2	
F-7-10	24	HS0A-91541-003	CLIP, HARNESS BAND(BLACK)	4	(145MM)
F-7-10	25	HZV5-91553-010	COLLAR, C.D.I. UNIT CASE	3	

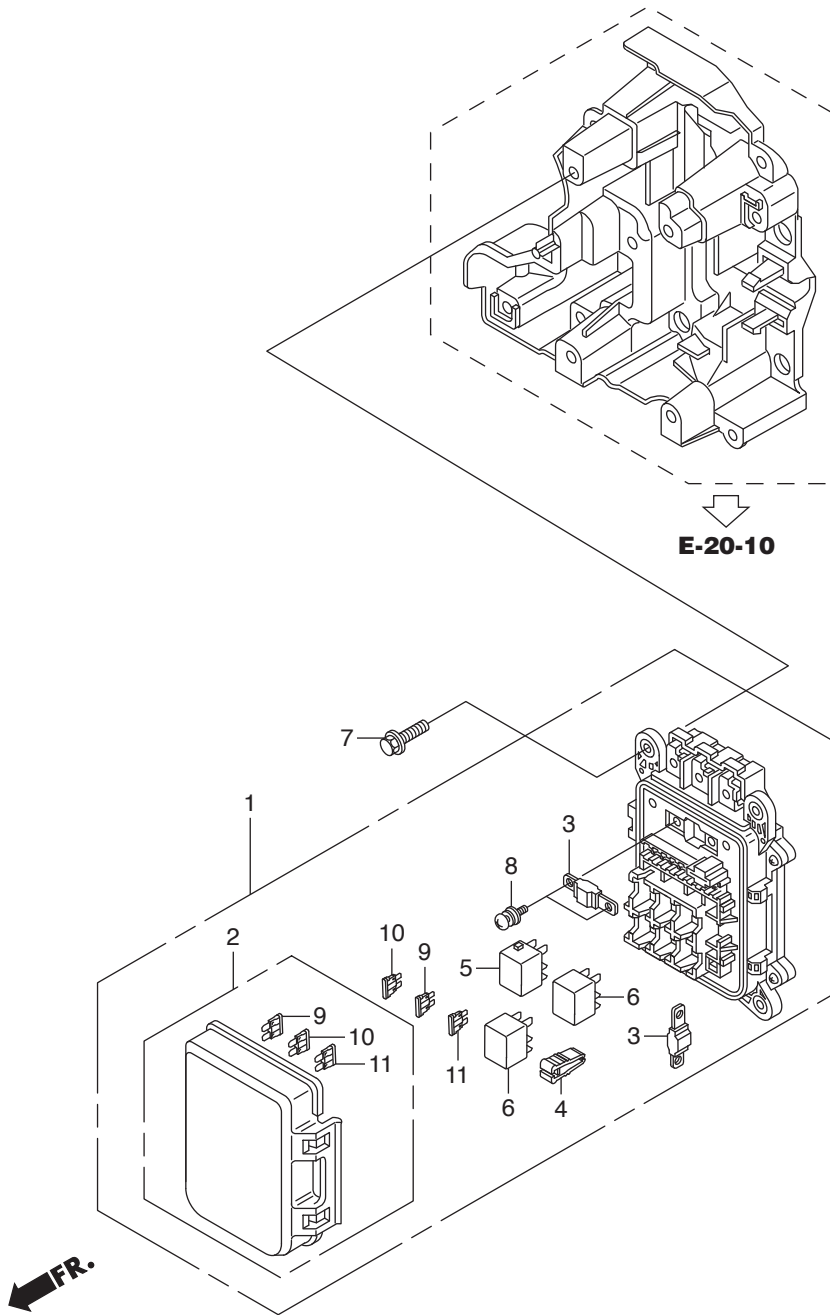



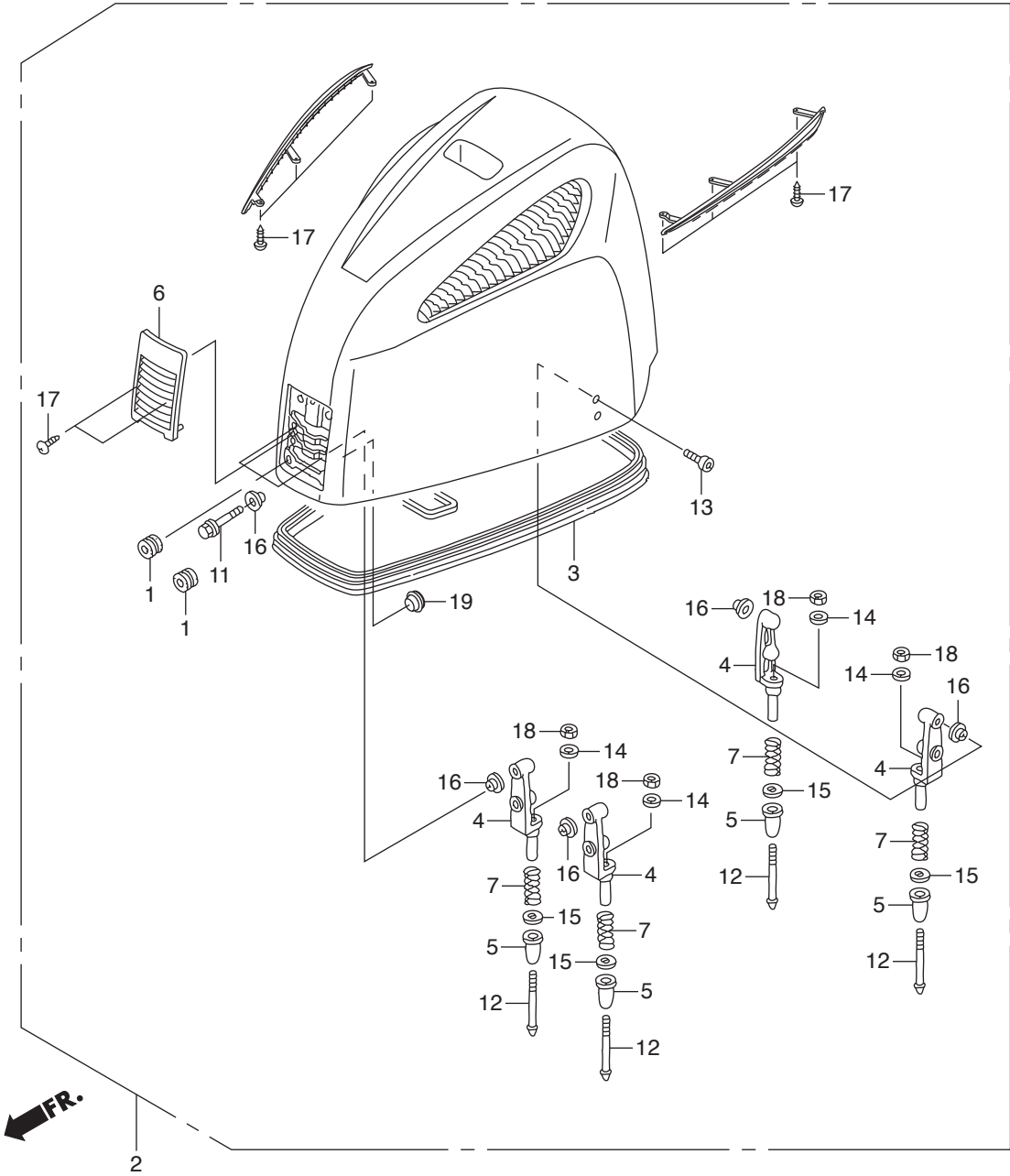





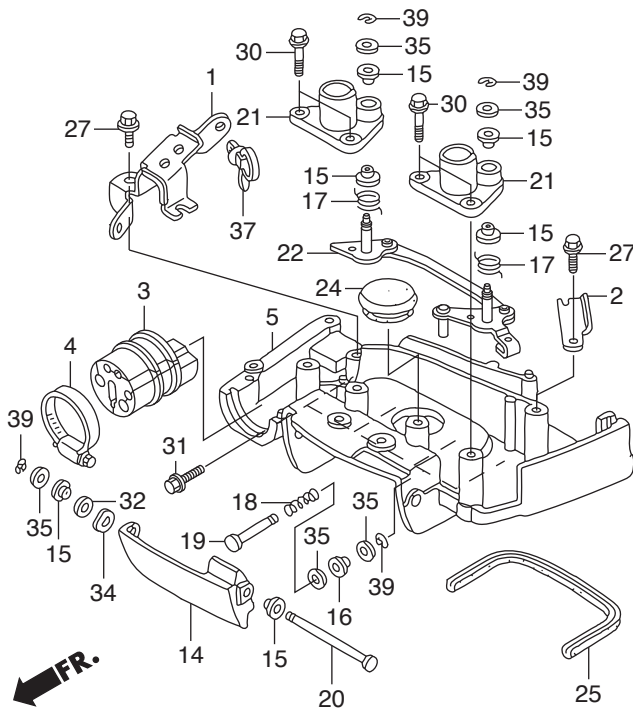
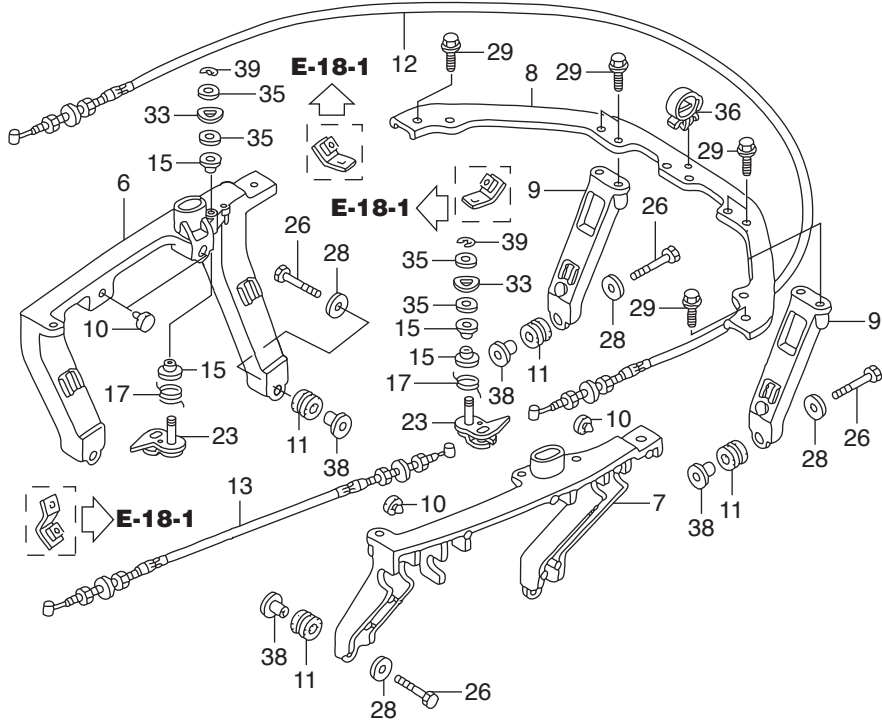

Ref.No.	Part No.	Description	Q' ty	Remarks	
			BF250A		
F-8-10	1	HZY3-32419-A00	BRACKET, CABLE	1	
F-8-10	2	HZY3-32421-000	PLATE, STARTER CABLE	1	
F-8-10	3	HZY3-40105-C01	GROMMET A, UNDER CASE	1	
F-8-10	4	HZY3-40119-003	BAND, UNDER CASE GROMMET	1	
F-8-10	5	HZY3-40154-000ZA	BRACKET, FR. COVER	1	*NH8* DARK GRAY
F-8-10	6	HZY3-40155-000	BRACKET, R. SIDE COVER	1	
F-8-10	7	HZY3-40157-000	BRACKET, L. SIDE COVER	1	
F-8-10	8	HZY3-40158-000	BRACKET A, RR. COVER	1	
F-8-10	9	HZY3-40159-000	BRACKET B, RR. COVER	2	
F-8-10	10	H196-47117-000	RUBBER, STOPPER	4	
F-8-10	11	H121-51640-730	RUBBER, FR. CARRIER CUSHION	6	
F-8-10	12	HZY3-60180-C01	CABLE COMP. A, COVER LOCK	1	
F-8-10	13	HZY3-60185-C01	CABLE COMP. B, COVER LOCK	1	
F-8-10	14	HZY3-63201-000ZC	LEVER, COVER LOCK	1	*T107* BAY BLUE
F-8-10	15	HZY3-63205-000	BUSH A, COVER LOCK	10	
F-8-10	16	HZY3-63208-000	BUSH B, COVER LOCK	1	
F-8-10	17	HZY3-63212-000	SPRING, COVER LOCK HOOK	4	
F-8-10	18	HZY3-63223-000	SPRING, LOCK LEVER RETURN	1	
F-8-10	19	HZY3-63224-000	SHAFT, COVER OPEN	1	
F-8-10	20	HZY3-63225-000	SHAFT, FR. LOCK	1	
F-8-10	21	HZY3-63226-000	HOLDER, STRIKER	2	
F-8-10	22	HZY3-63230-C00	LOCK ASSY., FR.	1	
F-8-10	23	HZX2-63260-C00	LOCK COMP., SIDE	2	
F-8-10	24	HZC0-63515-700	CAP, L. SIDE COVER	1	
F-8-10	25	HZY3-63729-003	SEAL D, UNDER COVER	1	
F-8-10	26	HZV5-90009-000	BOLT, HEX., 8X35	6	
F-8-10	27	HZY3-90021-000	BOLT, FLANGE, 6X14	2	
F-8-10	28	HML0-90101-720	WASHER, PLAIN, 8MM	6	
F-8-10	29	HZW9-90102-000	BOLT, FLANGE, 6X12	6	

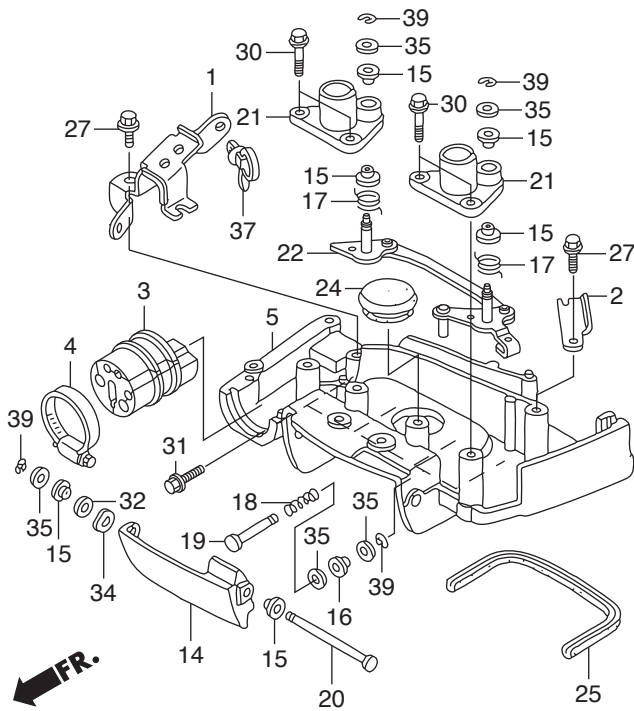
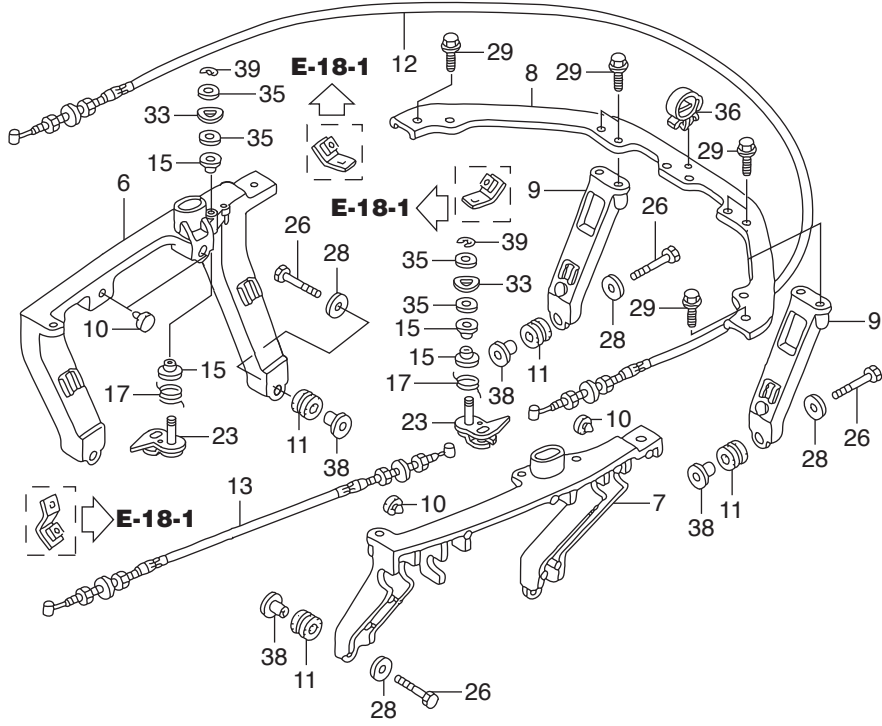



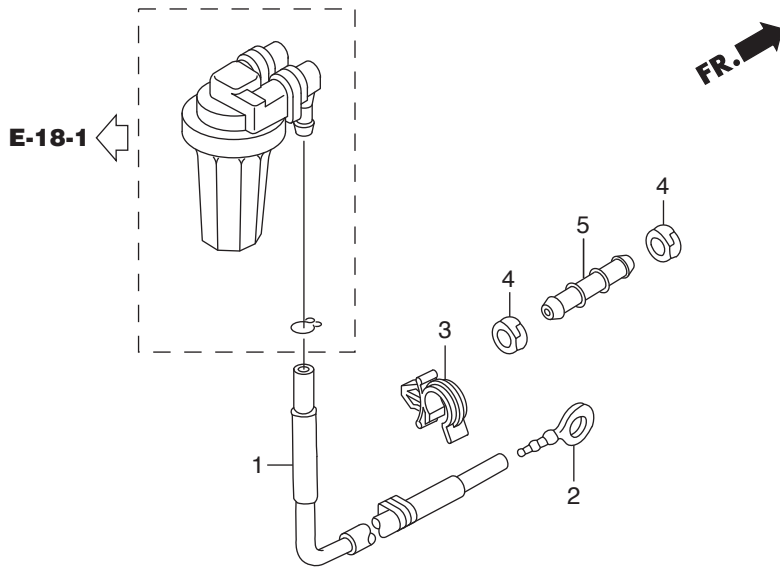



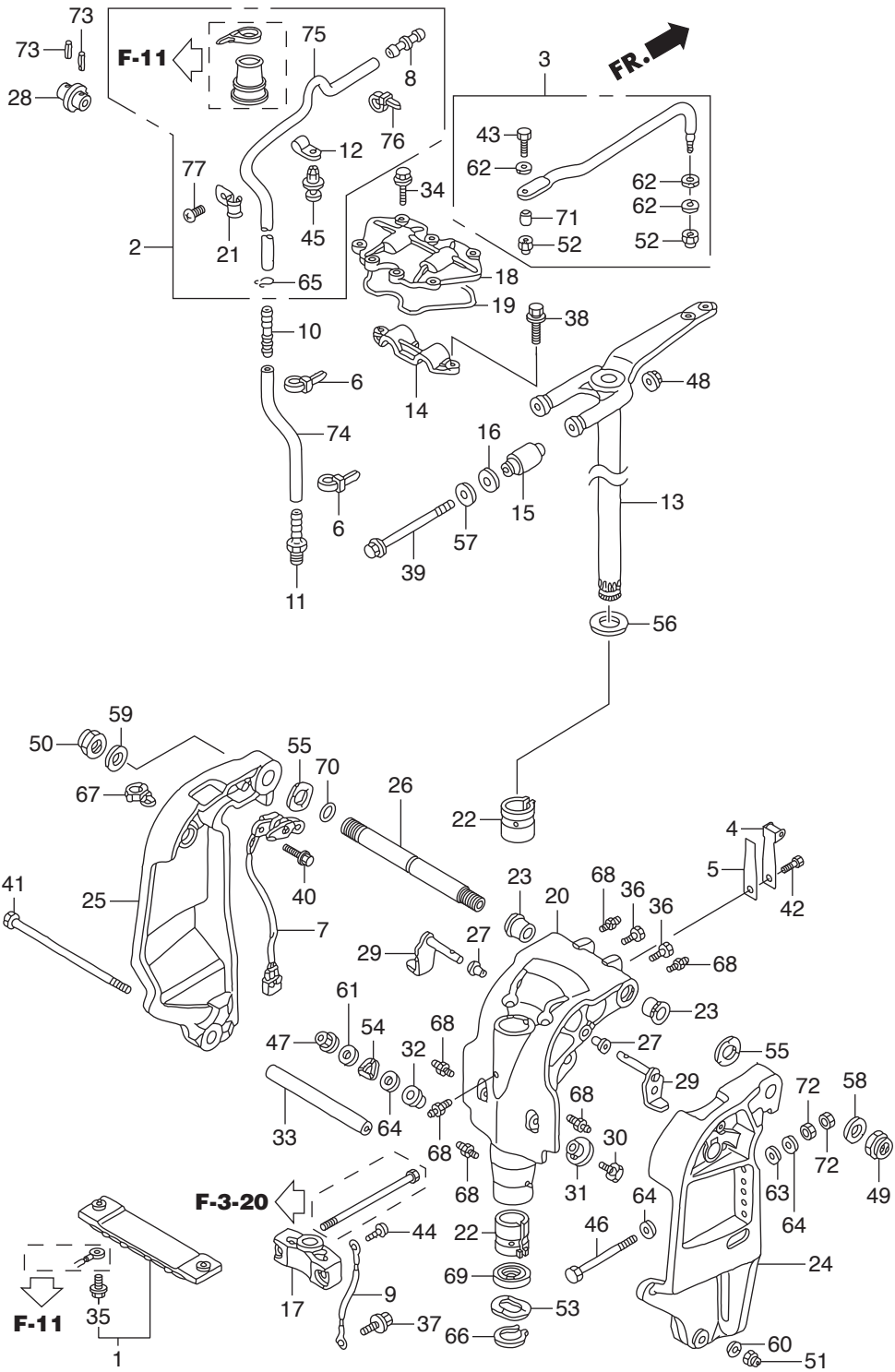



Ref.No.	Part No.	Description	Q' ty	Remarks	
			BF250A		
F-10	1	HZW1-06411-020	METAL KIT, ANODE	1	
F-10	2	HZY3-06412-000	TUBE KIT, SPEED SENSOR	1	
F-10	3	HZY3-06532-U00	ROD KIT, STEERING	1	
F-10	4	HZV1-24210-010	SPRING COMP., CLICK	1	
F-10	5	HZV4-24221-010	SPRING, CLICK ASSIST	1	
F-10	6	HKM3-32161-003	BAND, WIRE	2	
F-10	7	HZY3-35660-003	SENSOR ASSY., TRIM ANGLE	1	
F-10	8	H663-38562-920	JOINT B, WASHER TUBE(MITSUBA)	1	
F-10	9	HZY3-40219-013	WIRE, LEAD(1.5X116MM)	1	
F-10	10	HZV5-41171-000	END, NIPPLE	1	
F-10	11	HZV5-41172-000	NIPPLE, SENSOR	1	
F-10	12	HZY3-41179-A00	CLAMPER, SENSOR TUBE	2	
F-10	13	HZY3-50100-A11	FRAME COMP., MOUNTING(XL)	1	
F-10	14	HZY3-50109-000	HOUSING, UPPER MOUNTING	1	
F-10	15	HZY3-50151-000	MOUNT COMP., UPPER RUBBER	2	
F-10	16	HZY3-50153-000	RUBBER, UPPER MOUNT STOPPER	2	
F-10	17	HZY3-50161-610	HOUSING, LOWER CENTER MOUNTING	1	(XL)
F-10	18	HZY3-50166-000	COVER, UPPER MOUNT	1	
F-10	19	HZY3-50168-000	SEAL, UPPER MOUNT COVER	1	
F-10	20	HZY3-50201-C11ZC	CASE, SWIVEL	1	*T107* BAY BLUE
F-10	21	HZY3-50209-A00	CLAMP, TUBE	2	
F-10	22	HZY3-50211-000	LINER, SWIVEL CASE	2	
F-10	23	HZY3-50214-000	BUSH, SWIVEL CASE	2	
F-10	24	HZY3-50301-030ZC	BRACKET, R. STERN	1	*T107* BAY BLUE
F-10	25	HZY3-50311-020ZC	BRACKET, L. STERN	1	*T107* BAY BLUE
F-10	26	HZY3-50381-000	SHAFT, TILTING	1	
F-10	27	HZY3-50522-000	BUSH, TILT ARM	2	
F-10	28	HZY3-50527-000	BRACKET, TILTING	1	
F-10	29	HZY3-50529-000	STOPPER, TILT	2	

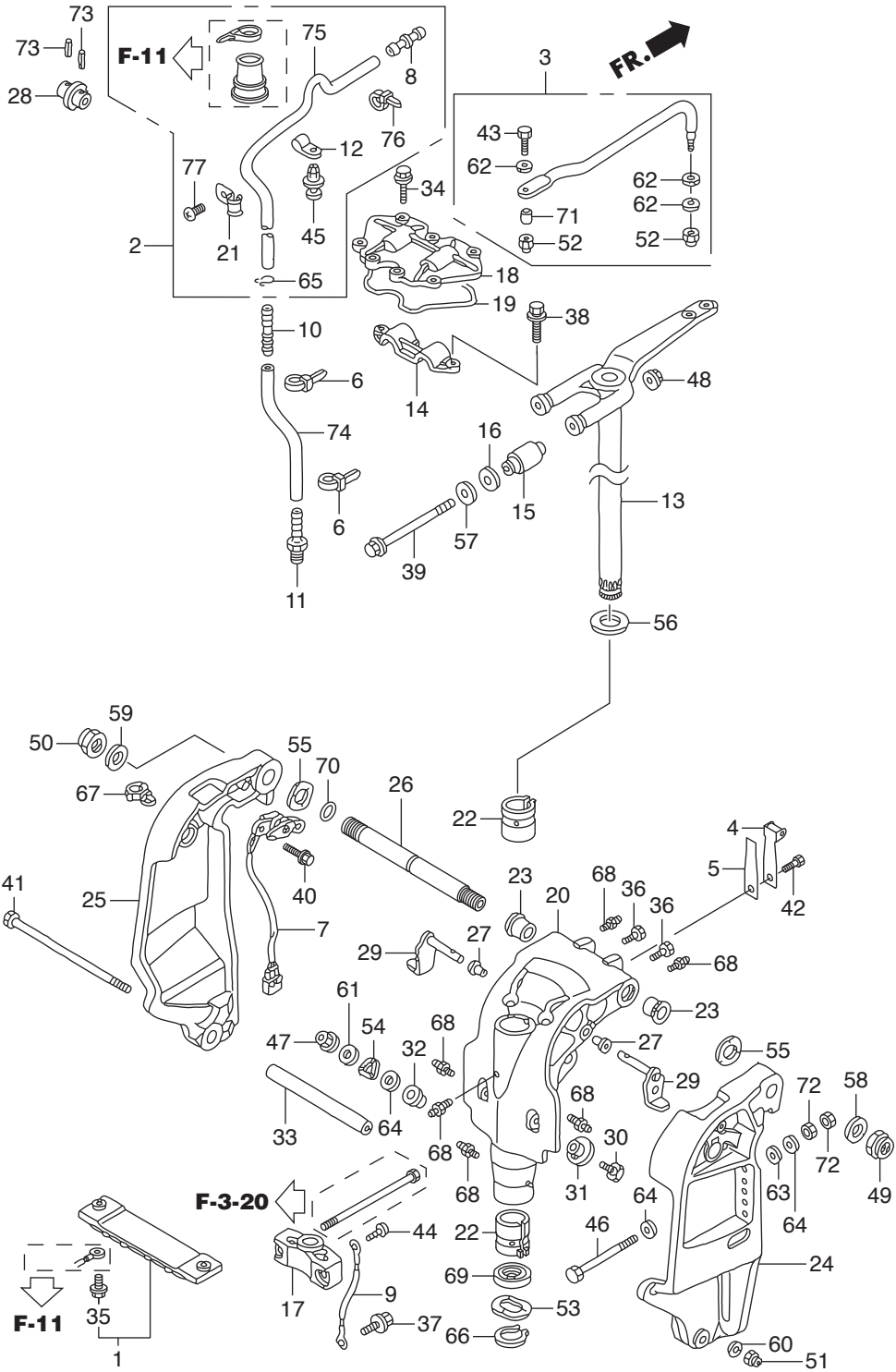

Ref.No.	Part No.	Description	Q' ty	Remarks	
			BF250A		
F-10	30	HZY3-56516-A00	RECEIVER, THRUST	2	
F-10	31	HZY3-56518-A00	BUSH A, THRUST RECEIVE	2	
F-10	32	HZY3-56519-A00	BUSH B, THRUST RECEIVE	2	
F-10	33	HZW1-56539-000	COLLAR, LOWER CYLINDER	1	
F-10	34	HZW9-90005-000	BOLT, FLANGE, 6X20	7	
F-10	35	HZW9-90009-000	BOLT, FLANGE, 6X23	2	
F-10	36	HZW1-90102-000	BOLT, 1/4-28UNF	2	
F-10	37	HZW9-90103-010	BOLT, FLANGE, 6X12	1	
F-10	38	HZY6-90103-000	BOLT-WASHER, 10X32	3	
F-10	39	HZY3-90104-010	BOLT, HEX., 12X200	2	
F-10	40	HZW9-90105-000	BOLT, FLANGE, 6X20	2	
F-10	41	HZW1-90108-000	BOLT, HEX., 10X235	1	
F-10	42	H881-90110-000	BOLT, HEX., 6X14	1	
F-10	43	HZY3-90117-000	BOLT, 3/8-24UNF	1	
F-10	44	HZV5-90119-000	SCREW, PAN, 6X8	1	
F-10	45	HZV5-90127-003	SCREW, RIVET, 5X10	2	
F-10	46	HZX2-90129-000	BOLT, HEX., 12X130	6	
F-10	47	HZY1-90205-000	NUT, SELF-LOCK, 6MM	2	
F-10	48	HZW5-90302-003	NUT, FLANGE, 12MM	2	
F-10	49	HZV5-90304-013	NUT, SELF-LOCK(7/8-14UNF)	1	
F-10	50	HZW1-90304-013	NUT, SELF-LOCK(25X2.0)	1	
F-10	51	HZW4-90306-003	NUT, FLANGE, 10MM	1	
F-10	52	HZV5-90307-003	NUT, SELF-LOCK(3/8-24UNF)	2	
F-10	53	HZV5-90501-000	WASHER, WAVE, 40MM	1	
F-10	54	HZY3-90501-A00	WASHER, WAVE, 12MM	2	
F-10	55	HZV5-90502-000	WASHER, WAVE, 26MM	2	
F-10	56	HZV5-90504-000	WASHER, THRUST, 34MM	1	
F-10	57	HZY3-90504-A00	WASHER, UPPER MOUNTING STOPPER	2	
F-10	58	HZY3-90509-000	WASHER, 7/8INCH	1	

F-10 STERN BRACKET/SWIVEL CASE

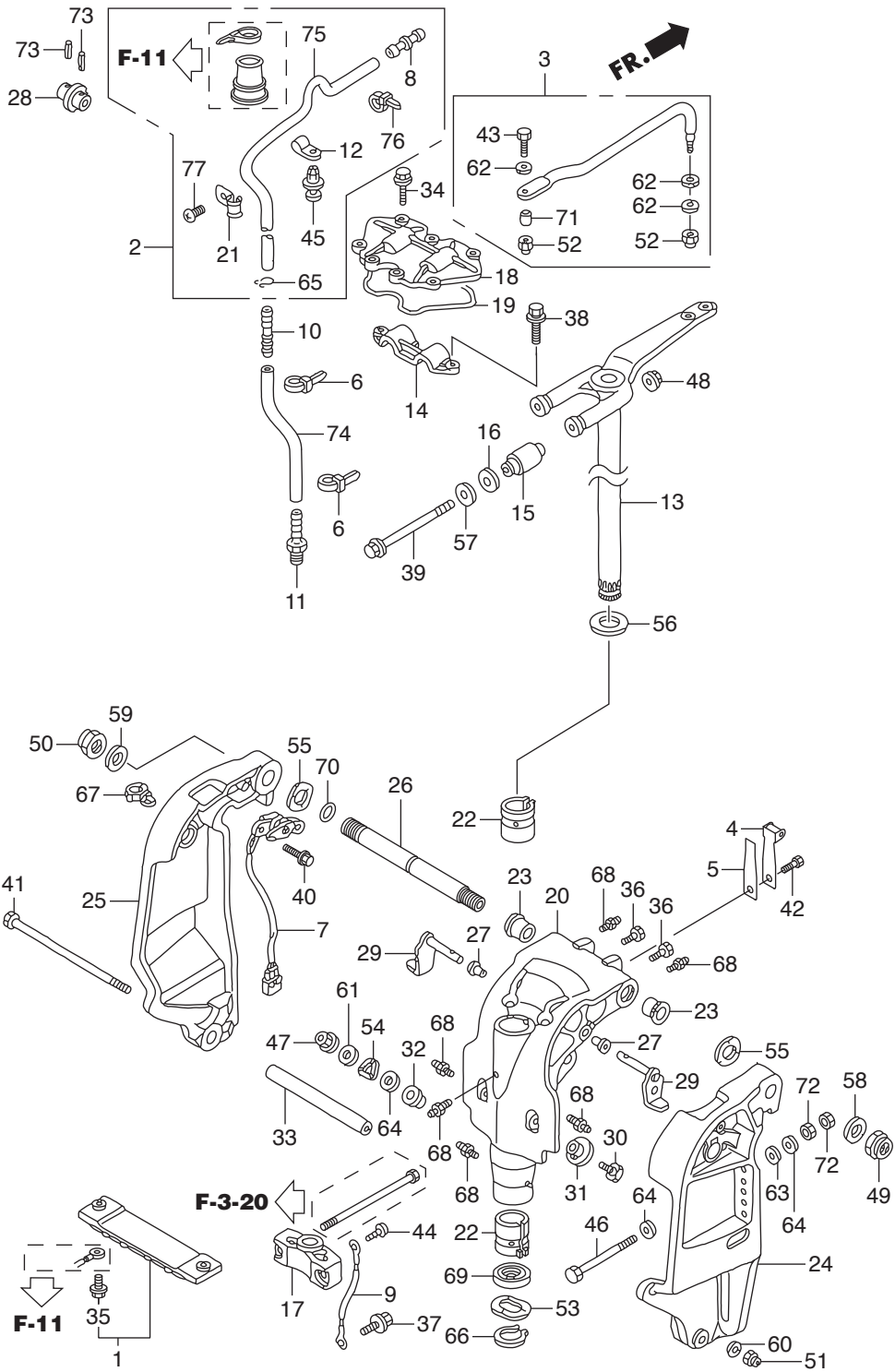



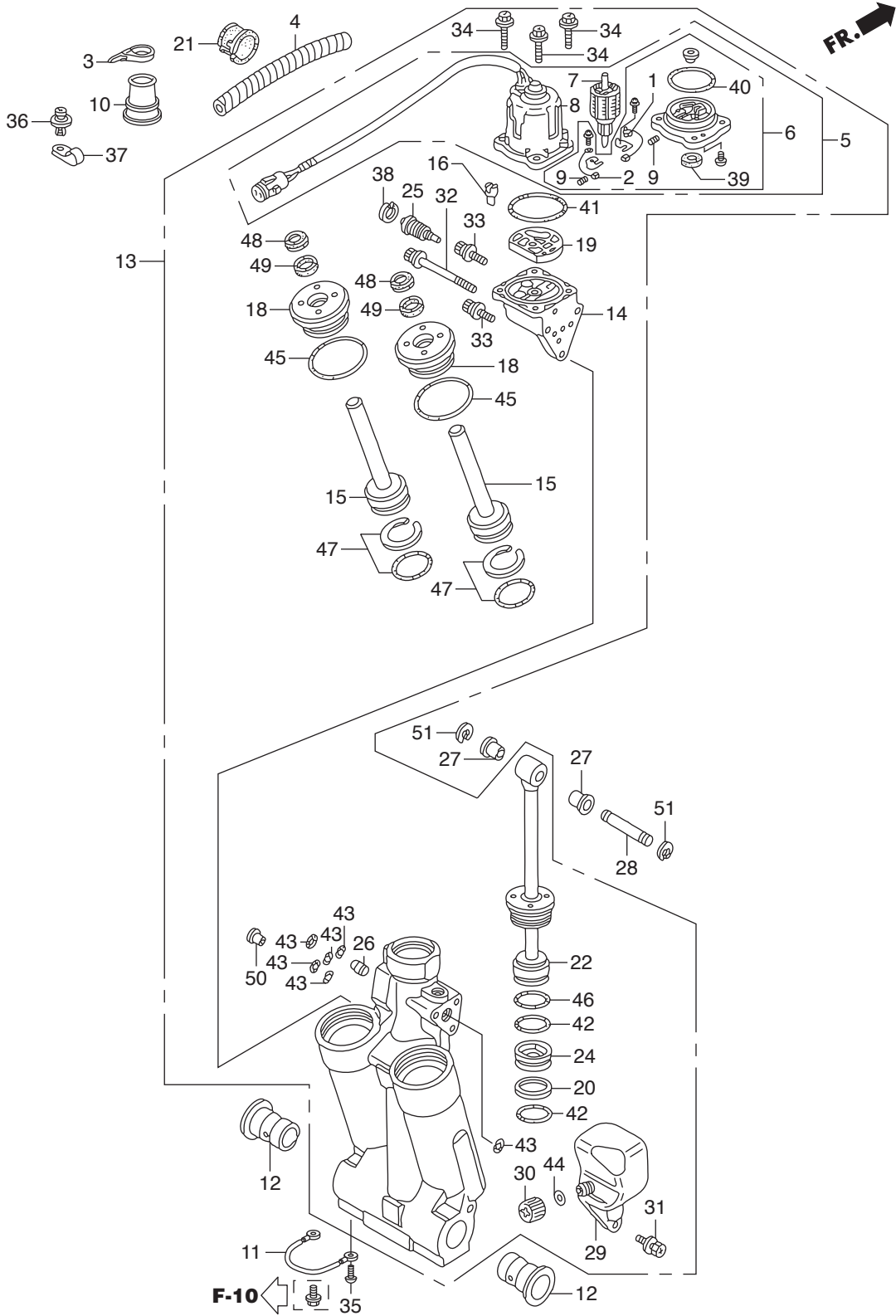

Ref.No.	Part No.	Description	Q' ty	Remarks	
			BF250A		
F-11	1	HZY3-30280-003	BREAKER ASSY.	1	
F-11	2	HZY3-31106-003	BRUSH ASSY.	1	
F-11	3	HMG9-35701-950	BAND(BLACK 3.5X140)	1	
F-11	4	HZW1-36104-003	TUBE, SPIRAL(12X14.6)	1	
F-11	5	HZX2-36120-003	MOTOR ASSY., POWER TILT	1	
F-11	6	HZY3-36122-013	BRACKET ASSY.	1	
F-11	7	HZY3-36123-013	ARMATURE COMP.	1	
F-11	8	HZX2-36129-003	YOKE ASSY.	1	
F-11	9	HZV5-36136-821	SPRING, MOTOR	2	
F-11	10	HZW1-40107-700	GROMMET, UNDER CASE(C)	2	
F-11	11	HZY3-40219-013	WIRE, LEAD(1.5X116MM)	1	
F-11	12	HZV5-50214-003	BUSH, SWIVEL CASE	2	
F-11	13	HZX2-56000-013	TRIM-TILT ASSY., POWER	1	
F-11	14	HZY3-56100-013	PUMP ASSY.	1	
F-11	15	HZW1-56110-701	ROD COMP., PISTON(B)	2	
F-11	16	HZW1-56113-701	JOINT, DRIVE	1	
F-11	18	HZY9-56115-003	GUIDE COMP., ROD	2	
F-11	19	HZW1-56116-701	FILTER B	1	
F-11	20	HZV5-56117-821	RING, BACK UP	1	
F-11	21	HZV5-56118-820	BUSH, MOTOR CODE	1	
F-11	22	HZY3-56120-013	ROD COMP., PISTON	1	
F-11	24	HZW1-56130-702	PISTON COMP., FREE	1	
F-11	25	HZY3-56170-013	VALVE COMP., MANUAL	1	
F-11	26	HZW1-56180-701	VALVE COMP., RESERVOIR	1	
F-11	27	HZV5-56513-000	BUSH, LOWER CYLINDER	2	
F-11	28	HZY3-56532-000	PIN, UPPER CYLINDER	1	
F-11	29	HZW1-56851-703	TANK, OIL	1	
F-11	30	HZW1-56860-701	CAP COMP., OIL TANK	1	
F-11	31	HZW1-90113-702	BOLT, RECESSED	3	

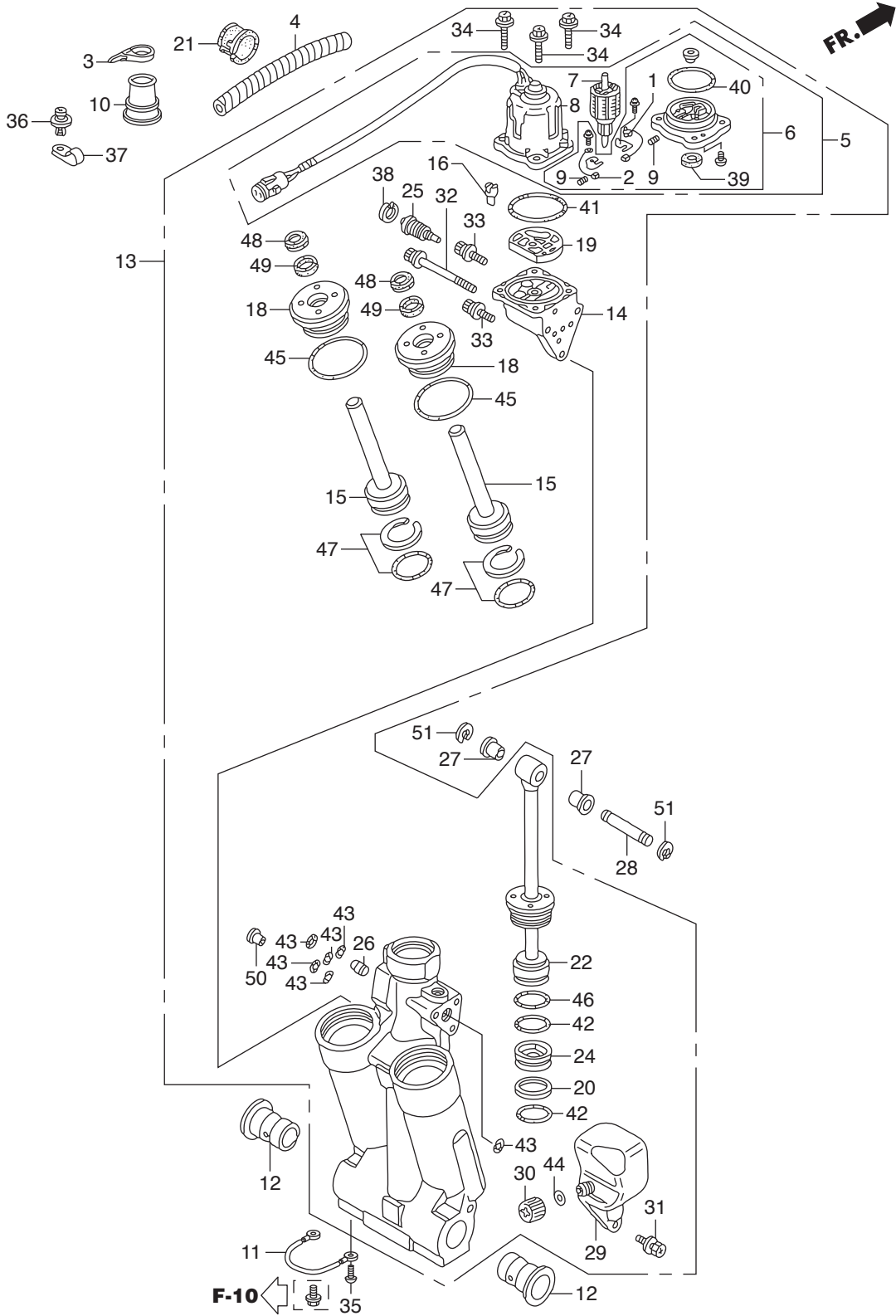





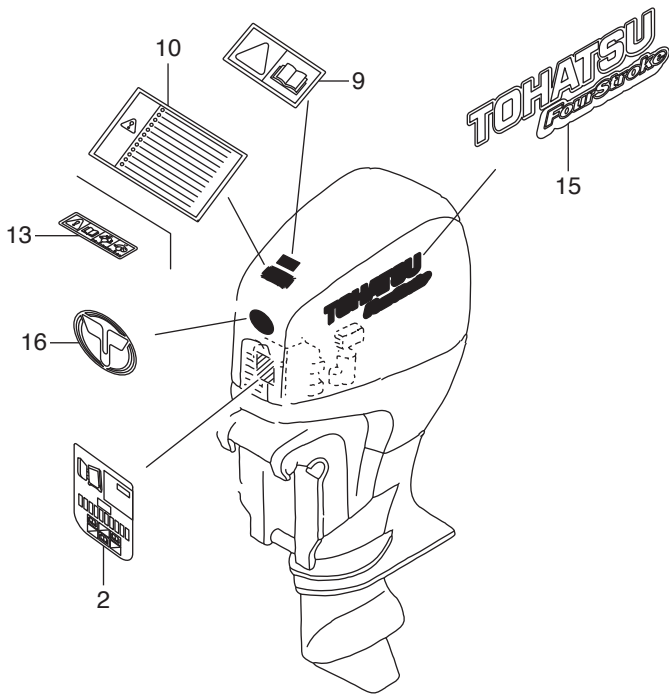
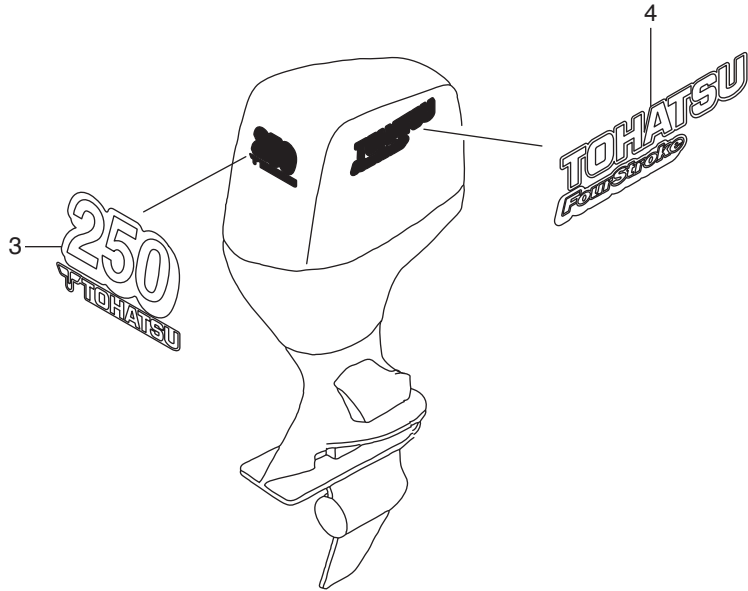



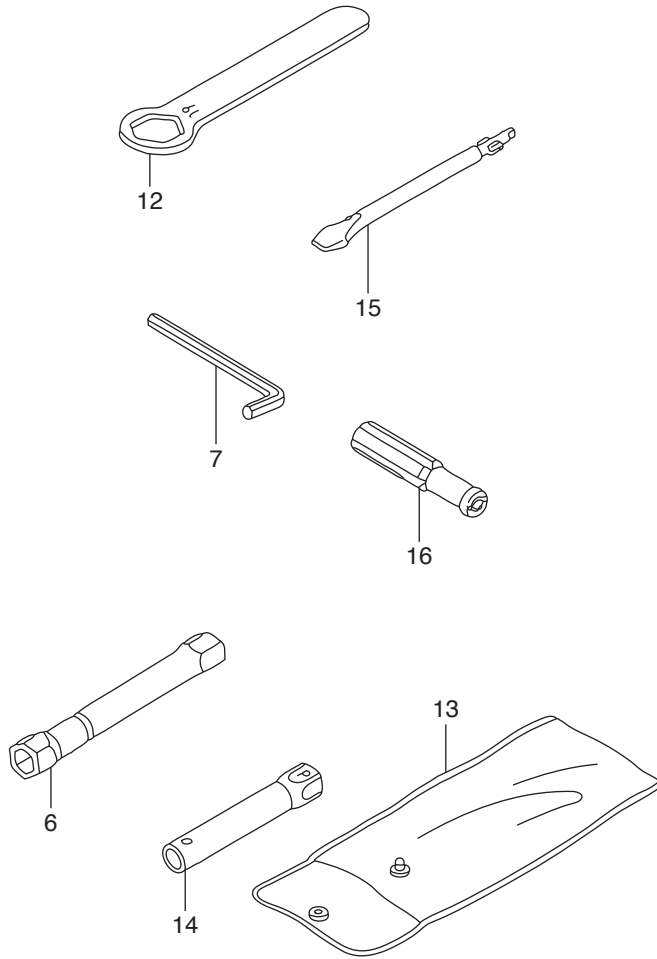



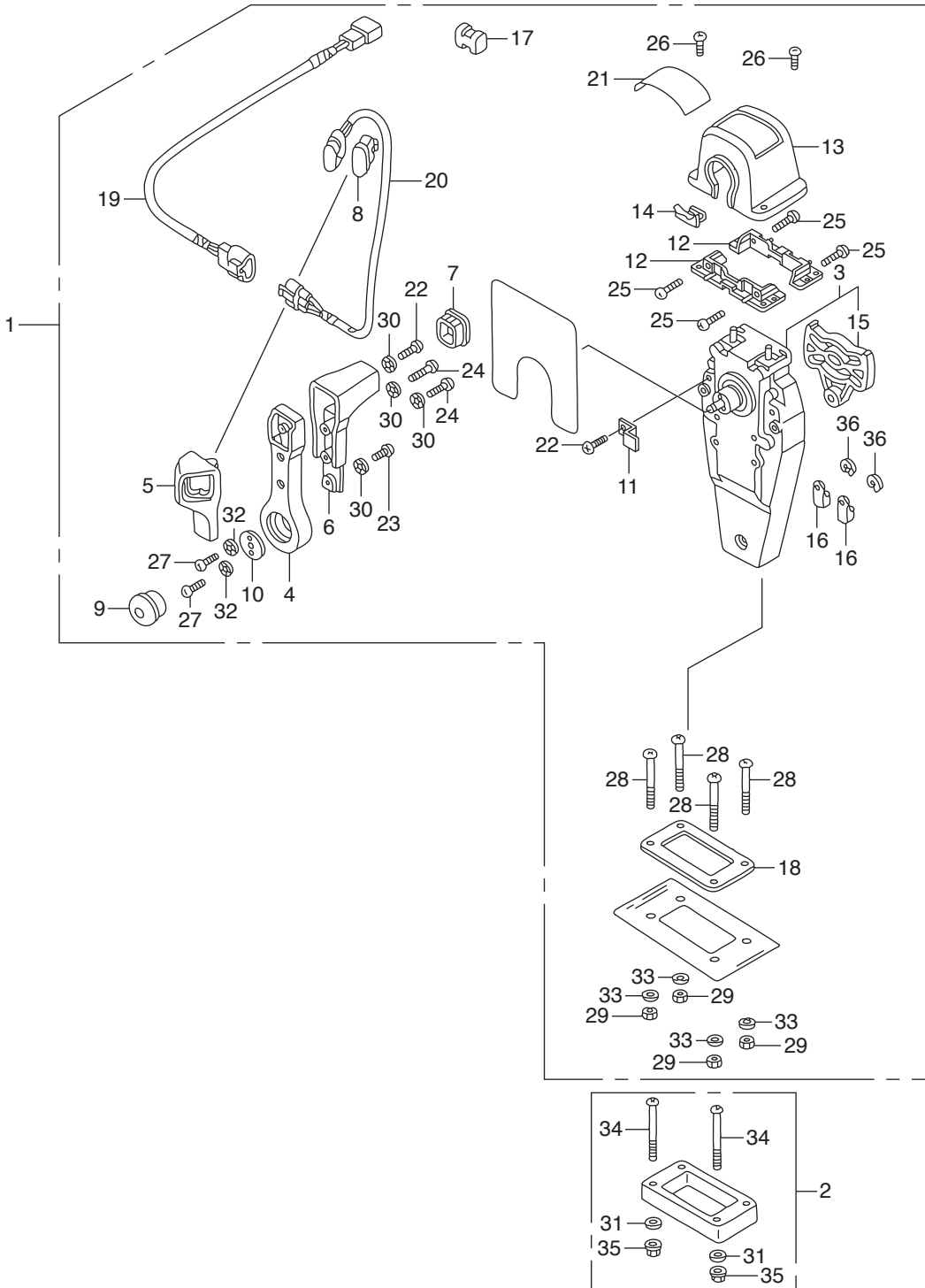

Ref.No.	Part No.	Description	Q' ty	Remarks	
			BF250A		
FOP-1	1	HZZ3-06240-R30	BOX KIT, REMOTE CONTROL	1	(TOP MOUNT SINGLE)(R.)
FOP-1	2	HZW5-06241-U00	SPACER KIT, REMOTE CONTROL BOX	1	(TOP MOUNT SINGLE)
FOP-1	3	HZW5-24810-U01	HOUSING ASSY., L. INNER	1	(TOP MOUNT)
FOP-1	4	HZW5-24811-U01	HANDLE, REMOTE CONTROL	1	
FOP-1	5	HZW5-24812-U01	COVER, L. GRIP	1	
FOP-1	6	HZW5-24813-U01	GRIP, REMOTE CONTROL HANDLE	1	
FOP-1	7	HZW5-24814-U01	CAP, GRIP	1	
FOP-1	8	HZW5-24815-U01	CAP, SWITCH	1	
FOP-1	9	HZW5-24816-U01	BUTTON, THROTTLE	1	
FOP-1	10	HZW5-24817-U01	PLATE, HANDLE	1	
FOP-1	11	HZW5-24818-U01	PLATE, CABLE CLAMP	1	
FOP-1	12	HZW5-24819-U01	BRACKET, REMOTE CONTROL	2	HOUSING
FOP-1	13	HZZ3-24820-R11	HOUSING COMP., REMOTE CONTROL	1	BOX
FOP-1	14	HZW5-24825-U01	HOUSING, LEAD	1	
FOP-1	15	HZW5-24826-U01	PLATE, DWELL	1	
FOP-1	16	HZW5-24831-U01	TERMINAL, CABLE	2	
FOP-1	17	HZW5-24832-U01	SPACER, CABLE CLAMP	1	
FOP-1	18	HZW5-24834-U01	PACKING, SINGLE	1	
FOP-1	19	HZW7-32530-U00	SUB HARNESS ASSY., POWER	1	TRIM-TILT(A)
FOP-1	20	HZW5-35370-U02	SWITCH ASSY., POWER TRIM-TILT	1	(A)
FOP-1	21	HZZ3-87703-R81	MARK, REMOTE CONTROL(SINGLE)	1	
FOP-1	22	HZW5-90101-U00	SCREW, PAN, 5X16	2	
FOP-1	23	HZW5-90102-U00	SCREW, PAN, 5X10	1	
FOP-1	24	HZW5-90103-U01	SCREW, PAN, 5X20	2	
FOP-1	25	HZW5-90104-U00	SCREW, PAN, 5X18	4	
FOP-1	26	HZW5-90105-U01	SCREW, PAN, 4X10	2	
FOP-1	27	HZW5-90106-U00	SCREW, PAN, 6X18	2	
FOP-1	28	HZW5-90107-U00	SCREW, PAN, 5X40	4	
FOP-1	29	HZW5-90301-U00	NUT, HEX., 5MM	4	

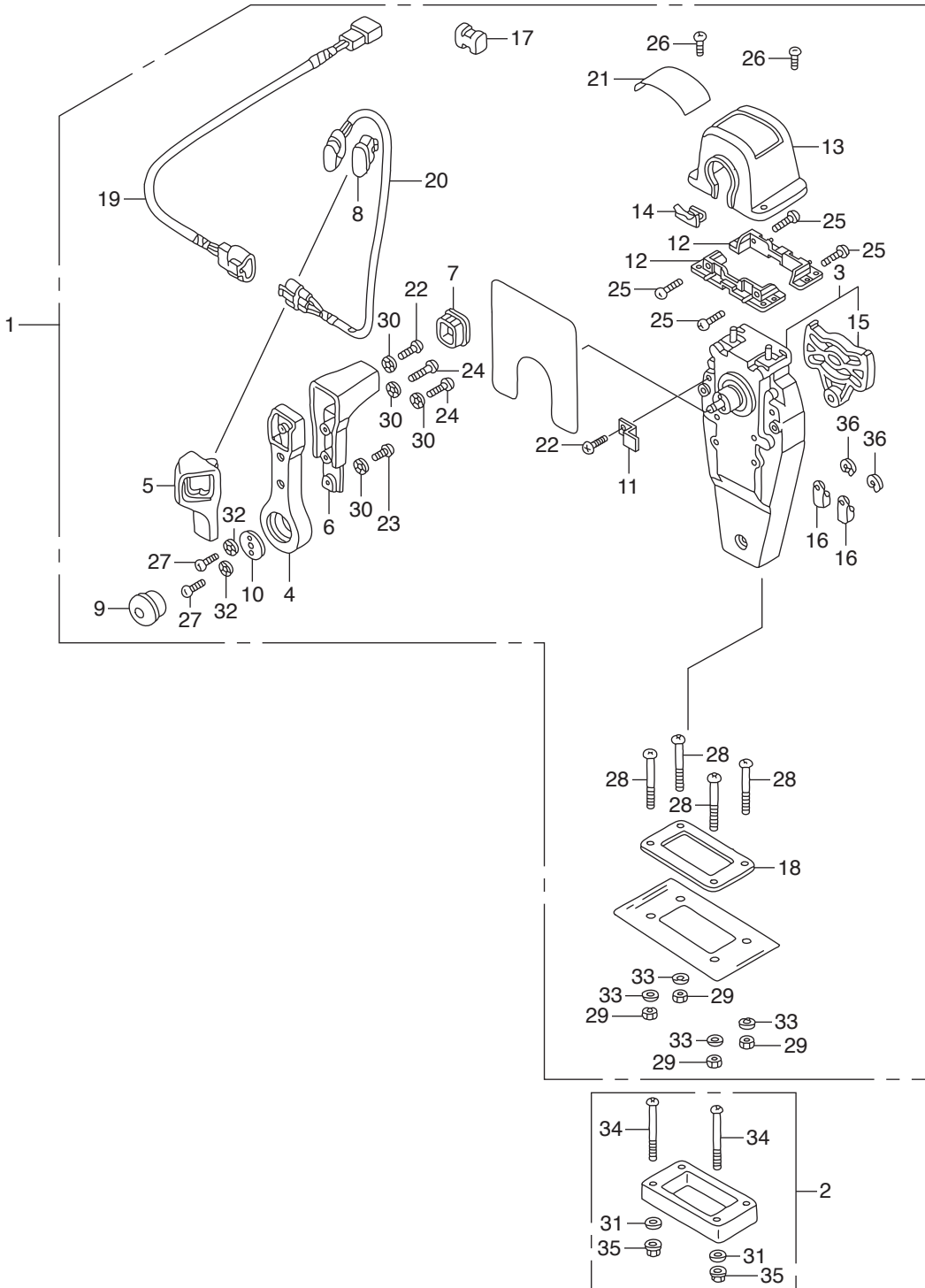





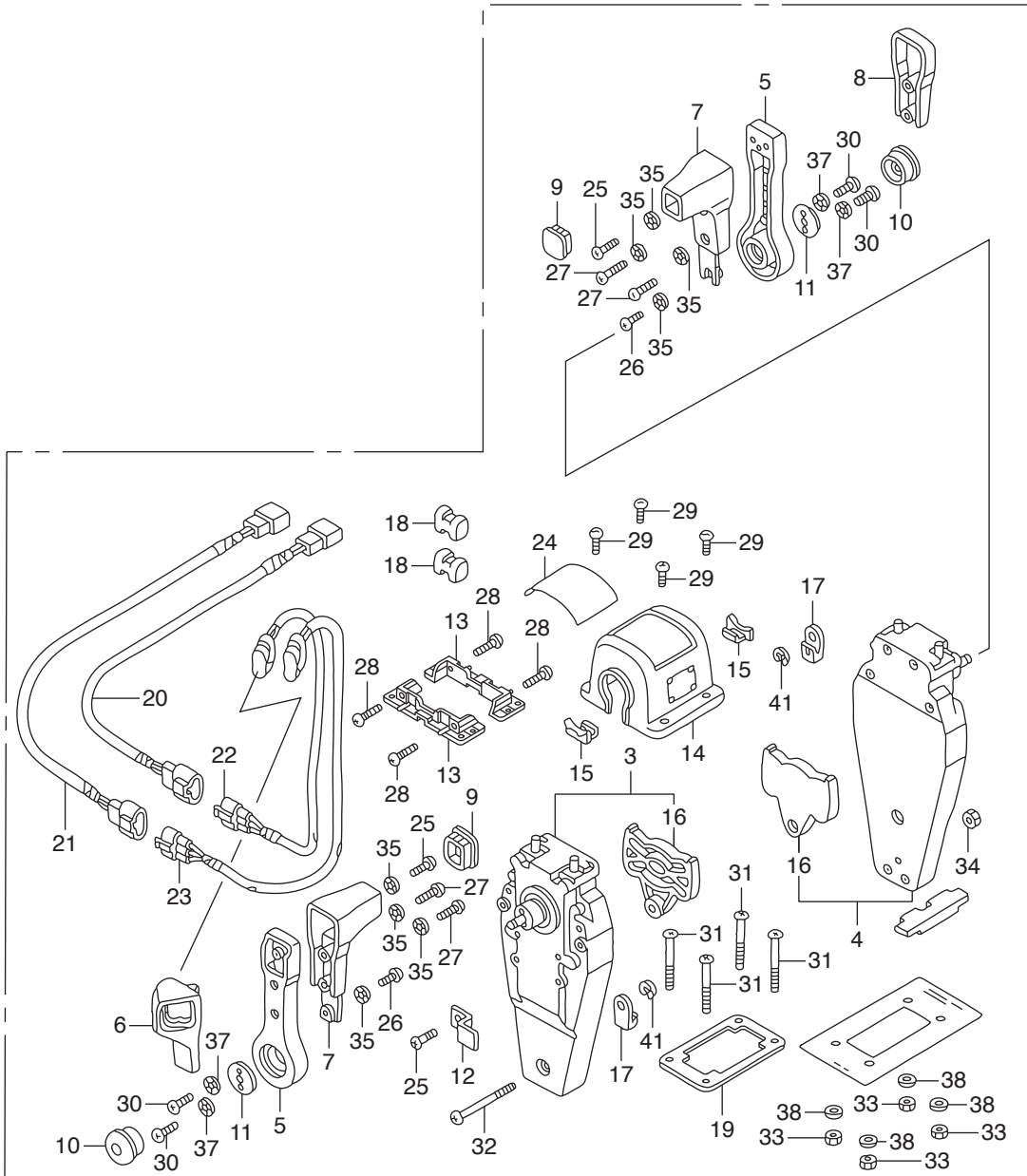

Ref.No.	Part No.	Description	Q' ty	Remarks	
			BF250A		
FOP-1-2	1	HZZ3-06240-R60	BOX KIT, REMOTE CONTROL	1	(TOP MOUNT DUAL)(R.)
FOP-1-2	2	HZW5-06241-U10	SPACER KIT, REMOTE CONTROL BOX	1	(TOP MOUNT DUAL)
FOP-1-2	3	HZW5-24810-U01	HOUSING ASSY., L. INNER	1	(TOP MOUNT)
FOP-1-2	4	HZW5-24810-U11	HOUSING ASSY., R. INNER	1	(TOP MOUNT)
FOP-1-2	5	HZW5-24811-U01	HANDLE, REMOTE CONTROL	2	
FOP-1-2	6	HZW5-24812-U01	COVER, L. GRIP	1	
FOP-1-2	7	HZW5-24813-U01	GRIP, REMOTE CONTROL HANDLE	2	
FOP-1-2	8	HZW5-24813-U21	COVER, DUAL GRIP	1	
FOP-1-2	9	HZW5-24814-U01	CAP, GRIP	2	
FOP-1-2	10	HZW5-24816-U01	BUTTON, THROTTLE	2	
FOP-1-2	11	HZW5-24817-U01	PLATE, HANDLE	2	
FOP-1-2	12	HZW5-24818-U01	PLATE, CABLE CLAMP	1	
FOP-1-2	13	HZW5-24819-U01	BRACKET, REMOTE CONTROL	2	HOUSING
FOP-1-2	14	HZZ3-24820-R21	HOUSING COMP., REMOTE CONTROL	1	BOX(DUAL)
FOP-1-2	15	HZW5-24825-U01	HOUSING, LEAD	2	
FOP-1-2	16	HZW5-24826-U01	PLATE, DWELL	2	
FOP-1-2	17	HZW5-24831-U01	TERMINAL, CABLE	4	
FOP-1-2	18	HZW5-24832-U01	SPACER, CABLE CLAMP	2	
FOP-1-2	19	HZW5-24834-U21	PACKING, DUAL	1	
FOP-1-2	20	HZW7-32530-U00	SUB HARNESS ASSY., POWER	1	TRIM-TILT(A)
FOP-1-2	21	HZW7-32530-U10	SUB HARNESS ASSY., POWER	1	TRIM-TILT(B)
FOP-1-2	22	HZW5-35370-U02	SWITCH ASSY., POWER TRIM-TILT	1	(A)
FOP-1-2	23	HZW5-35370-U12	SWITCH ASSY., POWER TRIM-TILT	1	(B)
FOP-1-2	24	HZZ3-87703-R01	MARK, REMOTE CONTROL(DUAL)	1	
FOP-1-2	25	HZW5-90101-U00	SCREW, PAN, 5X16	3	
FOP-1-2	26	HZW5-90102-U00	SCREW, PAN, 5X10	2	
FOP-1-2	27	HZW5-90103-U01	SCREW, PAN, 5X20	4	
FOP-1-2	28	HZW5-90104-U00	SCREW, PAN, 5X18	4	
FOP-1-2	29	HZW5-90105-U01	SCREW, PAN, 4X10	4	

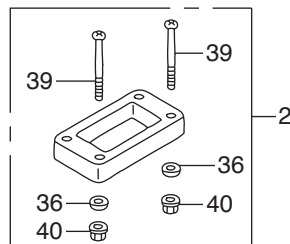
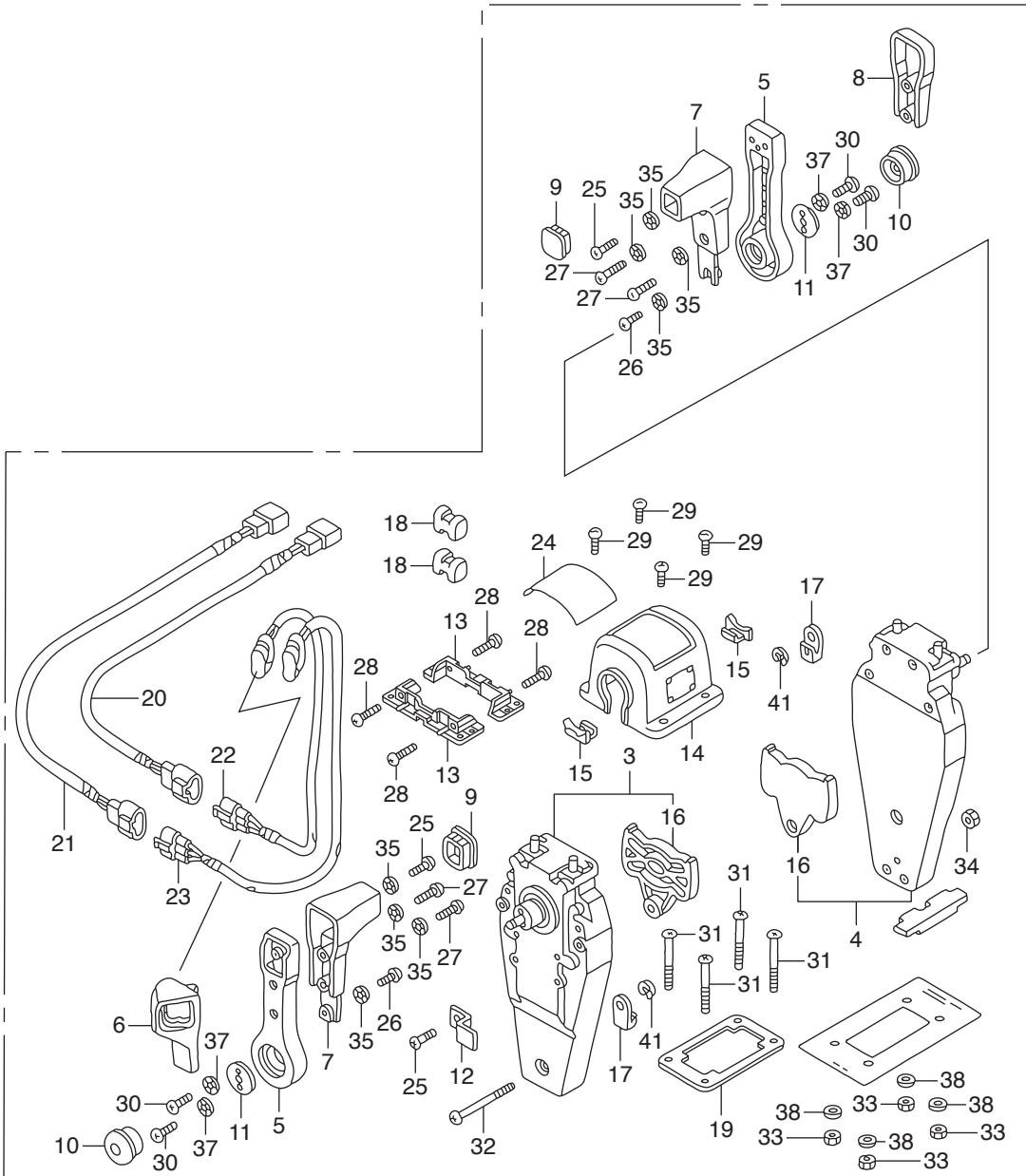



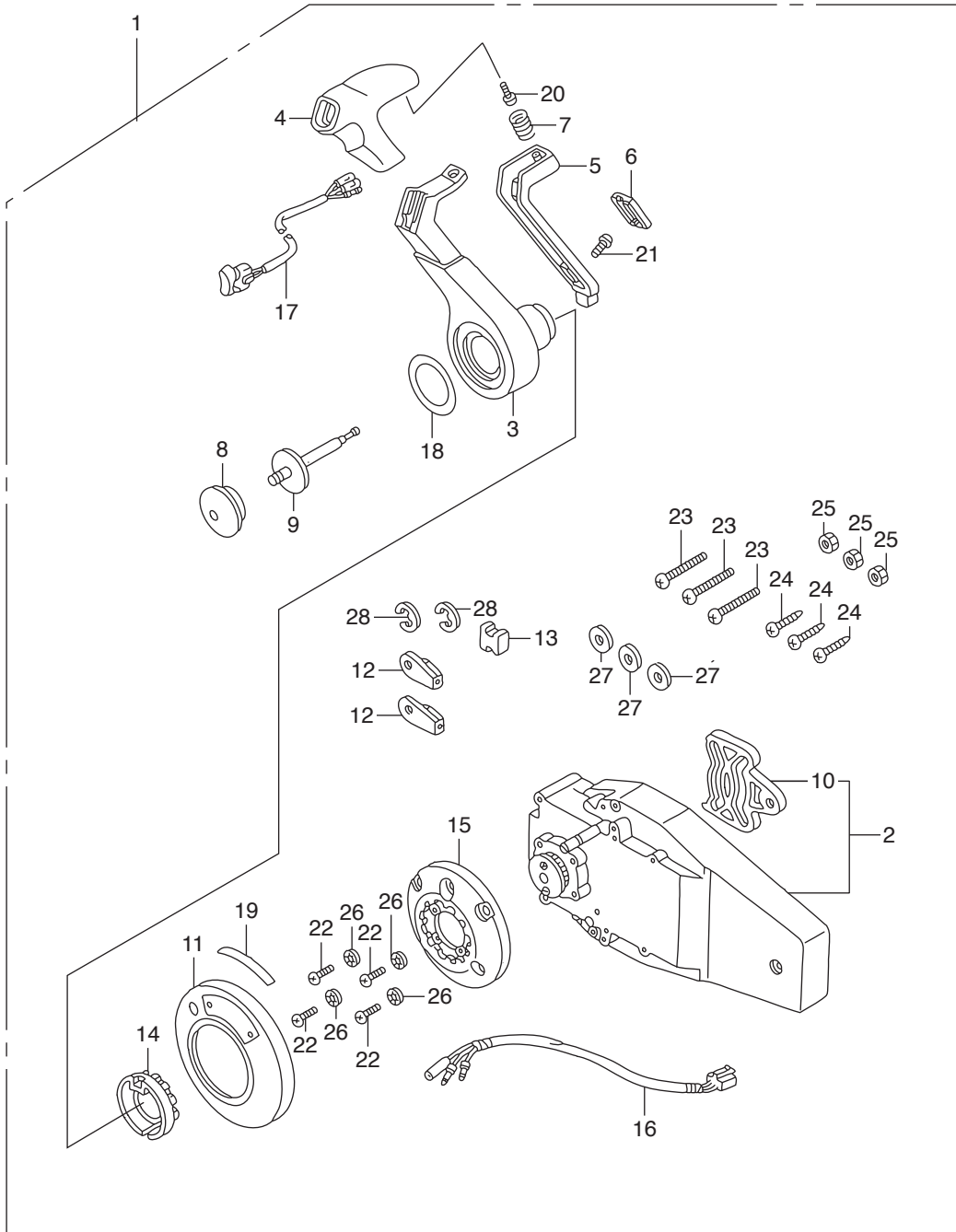

Ref.No.	Part No.	Description	Q' ty	Remarks	
			BF250A		
FOP-1-4	1	HZZ3-06240-R40	BOX KIT, REMOTE CONTROL	1	(FLUSH MOUNT)(R.)
FOP-1-4	2	HZW7-24810-U01	HOUSING ASSY., R. INNER	1	(FLUSH MOUNT)
FOP-1-4	3	HZW7-24811-U01	HANDLE, REMOTE CONTROL	1	
FOP-1-4	4	HZW7-24812-U01	COVER, GRIP	1	
FOP-1-4	5	HZW7-24813-U01	ARM, NEUTRAL LOCK	1	
FOP-1-4	6	HZW7-24814-U01	COVER, LOCK ARM	1	
FOP-1-4	7	HZW7-24815-U01	SPRING, NEUTRAL LOCK ARM	1	
FOP-1-4	8	HZW5-24816-U01	BUTTON, THROTTLE	1	
FOP-1-4	9	HZW7-24817-U01	SHAFT, THROTTLE BUTTON	1	
FOP-1-4	10	HZW5-24826-U01	PLATE, DWELL	1	
FOP-1-4	11	HZZ3-24830-R41	COVER ASSY.	1	
FOP-1-4	12	HZW5-24831-U01	TERMINAL, CABLE	2	
FOP-1-4	13	HZW5-24832-U01	SPACER, CABLE CLAMP	1	
FOP-1-4	14	HZW7-24832-U01	HOLDER, NEUTRAL LOCK	1	
FOP-1-4	15	HZW7-24833-U01	BASE	1	
FOP-1-4	16	HZW7-32530-U20	SUB HARNESS ASSY., POWER	1	TRIM-TILT(C)
FOP-1-4	17	HZW7-35370-U02	SWITCH ASSY., POWER TRIM-TILT	1	(C)
FOP-1-4	18	HZZ3-87701-R40	MARK, HANDLE FLUSH MOUNT	1	
FOP-1-4	19	HZW7-87703-U00	MARK, FLUSH MOUNT	1	
FOP-1-4	20	HZW5-90101-U00	SCREW, PAN, 5X16	1	
FOP-1-4	21	HZW7-90101-U01	SCREW, TRUSS, 4X12	1	
FOP-1-4	22	HZW7-90102-U01	SCREW, PAN, 5X30	4	
FOP-1-4	23	HZW7-90103-U01	SCREW, PAN, 6X35	3	
FOP-1-4	24	HZW7-90104-U01	SCREW, TAPPING, 6X30	3	
FOP-1-4	25	HZW7-90301-U01	NUT, HEX., 6MM	3	
FOP-1-4	26	HZW5-90501-U00	WASHER, LOCK, 5MM	4	
FOP-1-4	27	HZW7-90502-U00	WASHER, PLAIN, 6MM	3	
FOP-1-4	28	HCO-94540-06029	E-RING, 6MM	2	

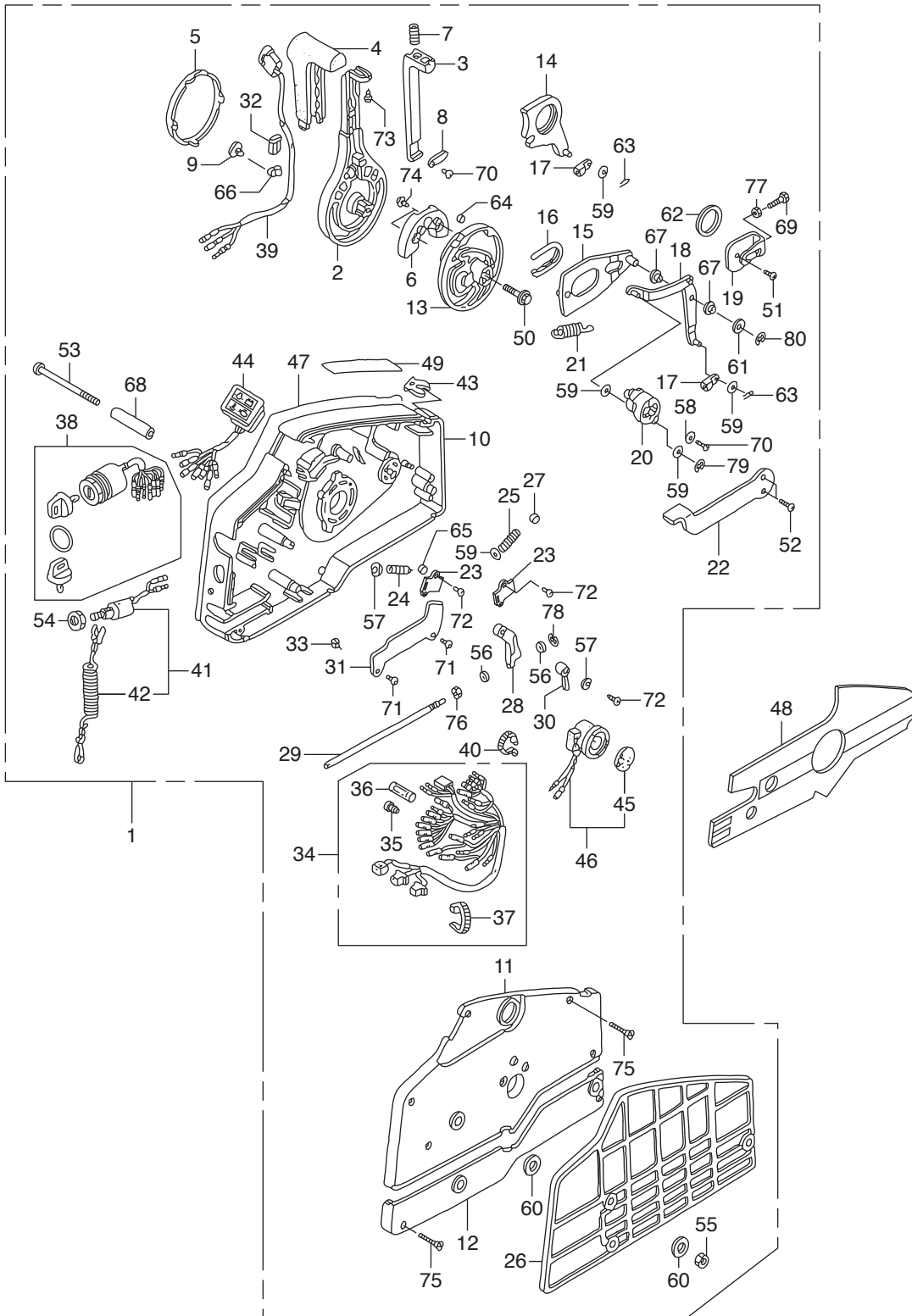



Ref.No.	Part No.	Description	Q' ty	Remarks	
			BF250A		
FOP-1-6	1	HZZ3-24800-R00	BOX ASSY., REMOTE CONTROL(EU)	1	XD
FOP-1-6		HZZ3-24800-R50	BOX ASSY., REMOTE CONTROL(EU)	1	XU
FOP-1-6	2	HZV5-24811-010	HANDLE, REMOTE CONTROL	1	
FOP-1-6	3	HZV5-24812-000	LEVER, HANDLE LOCK	1	
FOP-1-6	4	HZV5-24813-000	GRIP, REMOTE CONTROL HANDLE	1	
FOP-1-6	5	HZV5-24814-010	CAP, HANDLE	1	
FOP-1-6	6	HZV5-24815-010	BLOCK, NEUTRAL LOCK	1	
FOP-1-6	7	HZV5-24816-000	SPRING, REMOTE CONTROL HANDLE	1	
FOP-1-6	8	HZV5-24817-000	PLATE, LEVER SETTING	1	
FOP-1-6	9	HZV5-24818-003	CLAMP, HARNESS	1	
FOP-1-6	10	HZV5-24820-010	HOUSING COMP., REMOTE CONTROL	1	BOX(A)
FOP-1-6	11	HZV5-24830-010	HOUSING COMP., REMOTE CONTROL	1	BOX(B)
FOP-1-6	12	HZV5-24836-000	HOUSING, REMOTE CONTROL BOX(C)	1	
FOP-1-6	13	HZV5-24841-000	WHEEL, CONTROL	1	
FOP-1-6	14	HZV5-24845-000	ARM COMP., SHIFT LINK	1	
FOP-1-6	15	HZV5-24850-000	PLATE COMP., SLIDING	1	
FOP-1-6	16	HZV5-24854-000	COLLAR, SLIDING PLATE	1	
FOP-1-6	17	HZV5-24855-000	PIVOT, SHIFT	2	
FOP-1-6	18	HZV5-24860-000	ARM COMP., LINK JOINT	1	
FOP-1-6	19	HZV5-24865-000	BRACKET, LINK JOINT	1	
FOP-1-6	20	HZV5-24875-000	WHEEL, ACCELERATOR	1	
FOP-1-6	21	HZV5-24876-000	SPRING, ACCELERATOR WHEEL	1	
FOP-1-6	22	HZV5-24878-000	LEVER, IDLE	1	
FOP-1-6	23	HZV5-24881-000	PLATE, SPRING SETTING	2	
FOP-1-6	24	HZV5-24883-000	SPRING, SHIFT CLICK	1	
FOP-1-6	25	HZV5-24884-000	SPRING, CHOKE RETURN	1	
FOP-1-6	26	HZV5-24885-000	SPACER, REMOTE CONTROL BOX	1	
FOP-1-6	27	HZV5-24887-000	SPACER, CLICK SPRING	1	
FOP-1-6	28	HZV5-24891-000	BLOCK, THROTTLE FRICTION	1	



Ref.No.	Part No.	Description	Q' ty	Remarks	
			BF250A		
FOP-1-6	29	HZV5-24892-000	BOLT, FRICTION	1	
FOP-1-6	30	HZV5-24894-000	SPACER, NEUTRAL SWITCH	1	
FOP-1-6	31	HZV5-24895-000	CLAMP, POWER TILT CORD	1	
FOP-1-6	32	HZV5-24897-000	PIPE, HARNESS GUIDE	1	
FOP-1-6	33	HZV5-24898-000	SPACER, CABLE CLAMP	1	
FOP-1-6	34	HZZ5-32530-000	CABLE ASSY., REMOTE CONTROL(B)	1	
FOP-1-6	35	HZV5-32823-003	PLUG, INNER CONNECTOR	7	
FOP-1-6	36	HZV5-32824-003	PLUG, OUTER CONNECTOR	1	
FOP-1-6	37	H952-32901-770	TIE, CABLE(NATURAL)(2.4X92)	1	
FOP-1-6	38	HZZ3-35100-R11	SWITCH ASSY., COMBINATION	1	
FOP-1-6	39	HZV5-35370-823	SWITCH ASSY., POWER TRIM-TILT	1	
FOP-1-6	40	HMG9-35701-950	BAND(BLACK 3.5X140)	1	
FOP-1-6	41	HZV5-36180-033	SWITCH ASSY., EMERGENCY STOP	1	
FOP-1-6	42	HZV4-36182-651	CORD COMP., EMERGENCY	1	
FOP-1-6	43	HZV4-36187-652	CLIP, EMERGENCY LOCK	1	
FOP-1-6	44	HZZ5-37210-013	LAMP ASSY., INDICATION	1	
FOP-1-6	45	H341-38403-672	PLATE, WINKER BUZZER	1	
FOP-1-6	46	HZV5-38410-003	BUZZER COMP., WARNING	1	
FOP-1-6	47	HZZ3-87701-R00	PLATE, REMOTE CONTROL	1	XD
FOP-1-6		HZZ3-87701-R50	PLATE, REMOTE CONTROL(EU)	1	XU
FOP-1-6	48	HZZ5-87701-790	PLATE, REMOTE CONTROL(REVERSE)	1	
FOP-1-6	49	HZW9-87702-800	MARK, FAST IDLE	1	
FOP-1-6	50	HZW9-90008-000	BOLT, FLANGE, 8X35	1	
FOP-1-6	51	HMM4-90105-000	SCREW, PAN, 6X10	1	
FOP-1-6	52	HZW4-90108-000	SCREW, FLAT, 5X12	2	
FOP-1-6	53	HZV5-90125-000	SCREW, 6X95	3	
FOP-1-6	54	H921-90302-000	NUT, HEX., 16MM	1	
FOP-1-6	55	HZV4-90304-000	NUT, HEX., 6MM	3	
FOP-1-6	56	HZW4-90401-000	WASHER, PLAIN, 4MM	2	



Ref.No.	Part No.	Description	Q' ty	Remarks	
			BF250A		
FOP-1-6	57	HZW4-90402-000	WASHER, PLAIN, 5MM	2	
FOP-1-6	58	HZV4-90502-000	WASHER, PLAIN, 5MM	1	
FOP-1-6	59	H921-90504-010	WASHER, PLAIN, 6MM	5	
FOP-1-6	60	H921-90512-010	WASHER, 6MM	6	
FOP-1-6	61	H921-90518-000	WASHER, PLAIN, 8MM	1	
FOP-1-6	62	HZV5-90557-000	WASHER, 28MM	1	
FOP-1-6	63	HZV5-90751-000	PIN, LOCK, 6MM	2	
FOP-1-6	64	HZV5-90772-000	PIN, 6X6	1	
FOP-1-6	65	HZV5-91151-000	ROLLER, CLICK	1	
FOP-1-6	66	HSB6-91475-000	CLIP, WIRE HARNESS(6.3MM)	1	
FOP-1-6	67	HZV5-91567-000	COLLAR, LINK JOINT	2	
FOP-1-6	68	HZV5-91570-000	COLLAR, DISTANCE, 6X10X43.5	3	
FOP-1-6	69	HCO-92101-05016-4J	BOLT, HEX., 5X16	1	
FOP-1-6	70	HCO-93500-05010-4J	SCREW, PAN, 5X10	2	
FOP-1-6	71	HCO-93901-250J0	SCREW, TAPPING, 5X8	2	
FOP-1-6	72	HCO-93901-251J0	SCREW, TAPPING, 5X10	3	
FOP-1-6	73	HCO-93901-252J0	SCREW, TAPPING, 5X12	1	
FOP-1-6	74	HCO-93903-262J0	SCREW, TAPPING, 6X16	2	
FOP-1-6	75	HCO-93905-255J0	SCREW, TAPPING, 5X25	7	
FOP-1-6	76	HCO-94001-06490-0S	NUT, HEX., 6MM	1	
FOP-1-6	77	HCO-94002-05490-0S	NUT, HEX., 5MM	1	
FOP-1-6	78	HCO-94540-03029	E-RING, 3MM	1	
FOP-1-6	79	HCO-94540-04029	E-RING, 4MM	1	
FOP-1-6	80	HCO-94540-07029	E-RING, 7MM	1	

FOP-3

METER

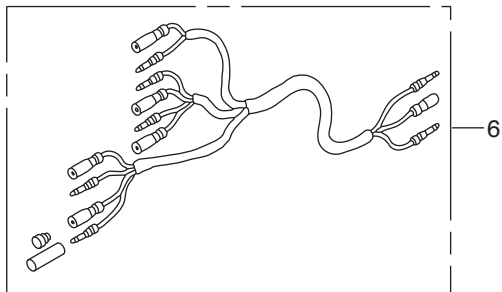
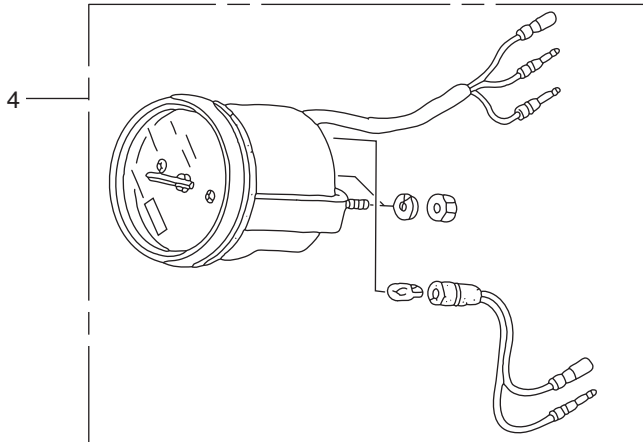
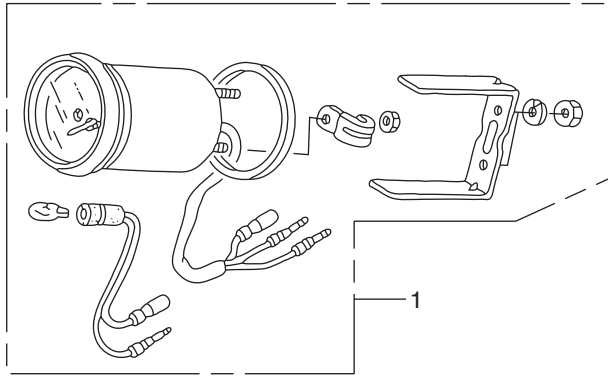



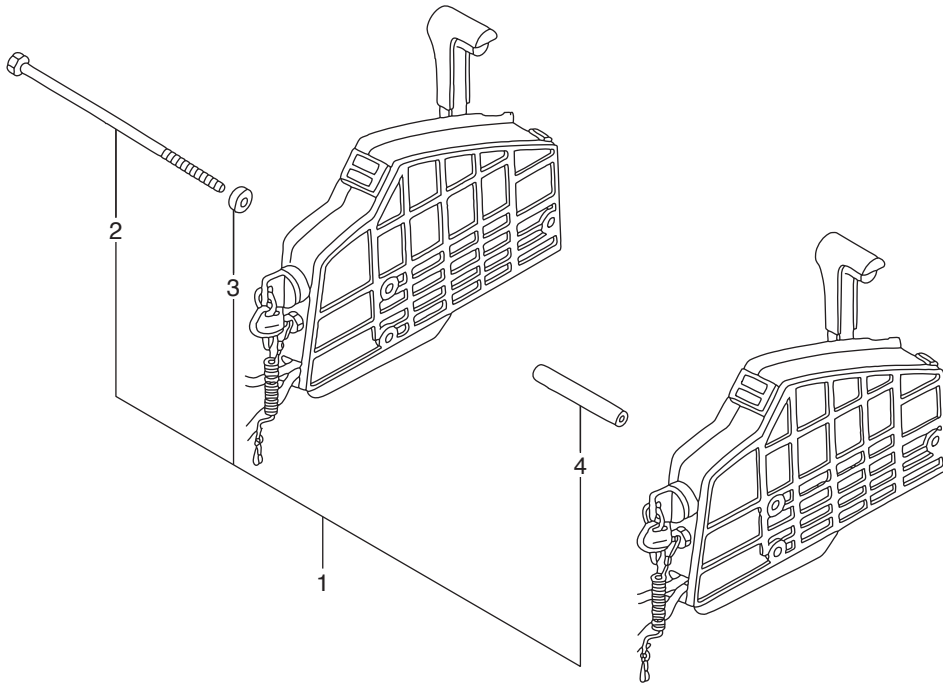





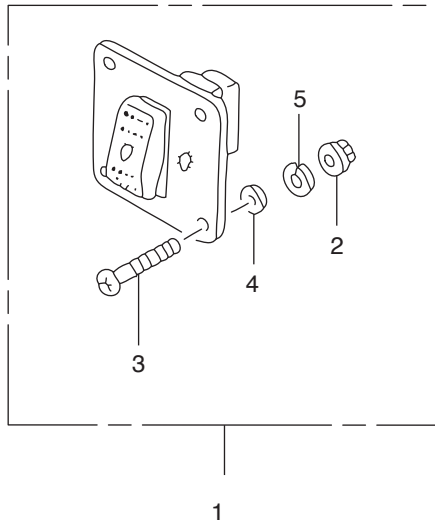



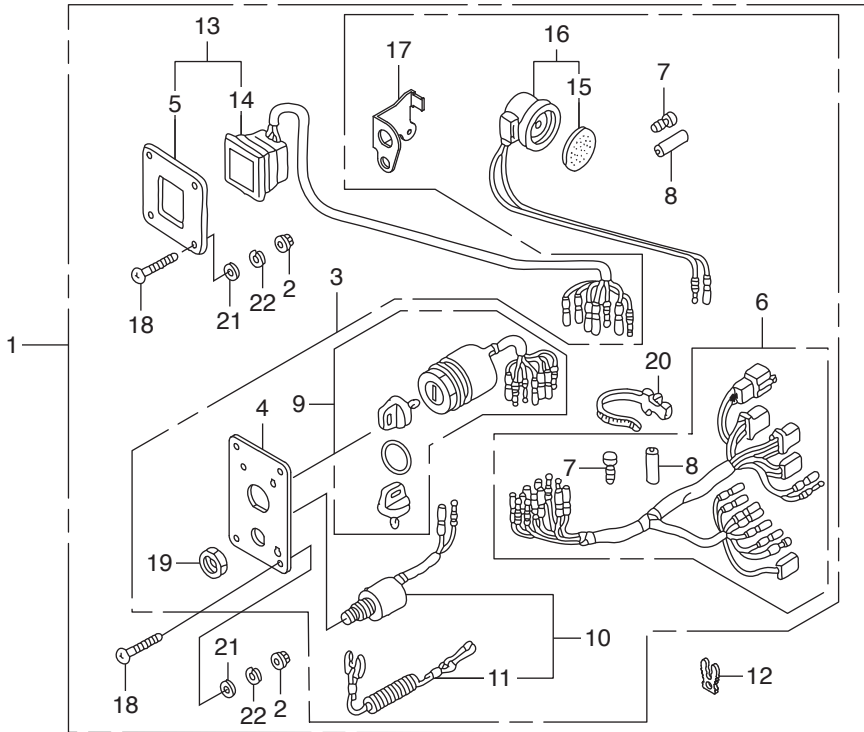

Ref.No.	Part No.	Description	Q' ty	Remarks	
			BF250A		
FOP-7	1	HZZ3-06323-R20	PANEL KIT, SWITCH(B)(4-LED)	1	XD
FOP-7		HZZ3-06323-R00	PANEL KIT, SWITCH(B)(4-LED) (EU)	1	XU
FOP-7	2	HMT8-18334-770	NUT, FLANGE, 5MM	8	
FOP-7	3	HZZ3-32341-R31	PANEL ASSY., SWITCH	1	XD
FOP-7		HZZ3-32341-R01	PANEL ASSY., SWITCH	1	XU
FOP-7	4	HZZ3-32346-R21	PANEL, CONTROL	1	XD
FOP-7		HZZ3-32346-R01	PANEL, CONTROL	1	XU
FOP-7	5	HZZ3-32347-R01	PANEL, CONTROL	1	
FOP-7	6	HZZ5-32545-000	HARNESS ASSY., SWITCH PANEL	1	
FOP-7	7	HZV5-32823-003	PLUG, INNER CONNECTOR	8	
FOP-7	8	HZV5-32824-003	PLUG, OUTER CONNECTOR	3	
FOP-7	9	HZZ3-35100-R11	SWITCH ASSY., COMBINATION	1	
FOP-7	10	HZV5-36180-033	SWITCH ASSY., EMERGENCY STOP	1	
FOP-7	11	HZV4-36182-651	CORD COMP., EMERGENCY	1	
FOP-7	12	HZV4-36187-652	CLIP, EMERGENCY LOCK	1	
FOP-7	13	HZZ3-37205-R01	PANEL ASSY., INDICATOR(4-LED)	1	
FOP-7	14	HZZ5-37210-762	LAMP ASSY., INDICATION(4-LED)	1	
FOP-7	15	H341-38403-672	PLATE, WINKER BUZZER	1	
FOP-7	16	HZV5-38410-003	BUZZER COMP., WARNING	1	
FOP-7	17	HZZ5-38414-003	BRACKET, BUZZER	1	
FOP-7	18	HZW5-90109-000	SCREW, PAN, 5X40	8	
FOP-7	19	H921-90302-000	NUT, HEX., 16MM	1	
FOP-7	20	HSC2-90649-003	BAND, WIRE HARNESS(NATURAL)	1	(150MM)
FOP-7	21	HCO-94103-05400	WASHER, PLAIN, 5MM	8	
FOP-7	22	HCO-94111-05400	WASHER, SPRING, 5MM	8	

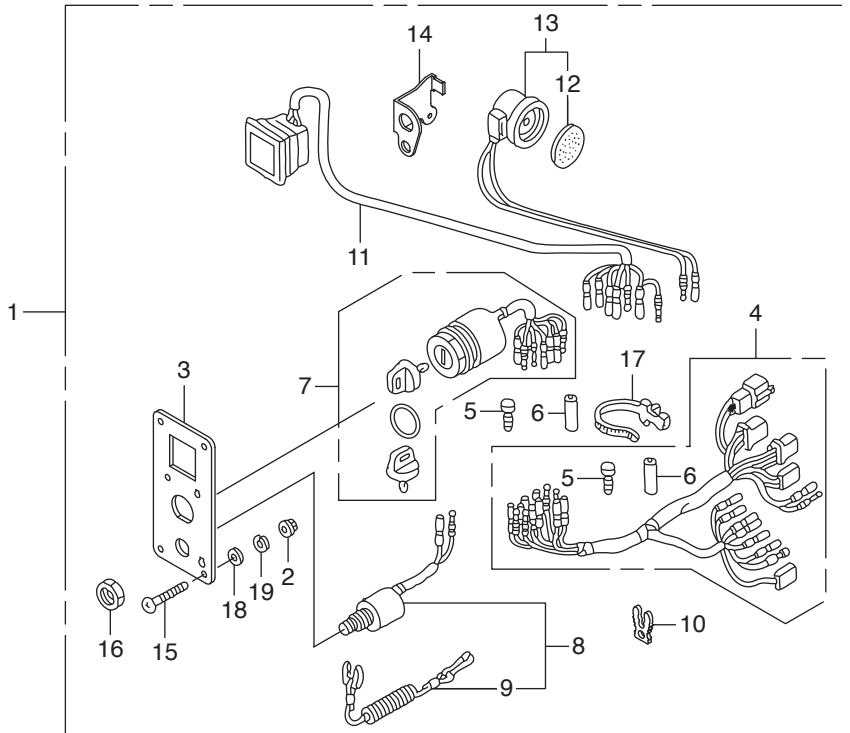

Ref.No.	Part No.	Description	Q' ty	Remarks	
			BF250A		
FOP-7-1	1	HZZ3-06323-R30	PANEL KIT, SWITCH(4-LED)	1	XD
FOP-7-1		HZZ3-06323-R10	PANEL KIT, SWITCH(4-LED) (EU)	1	XU
FOP-7-1	2	HMT8-18334-770	NUT, FLANGE, 5MM	4	
FOP-7-1	3	HZZ3-32346-R31	PANEL, CONTROL	1	XD
FOP-7-1		HZZ3-32346-R11	PANEL, CONTROL	1	XU
FOP-7-1	4	HZZ5-32545-000	HARNESS ASSY., SWITCH PANEL	1	
FOP-7-1	5	HZV5-32823-003	PLUG, INNER CONNECTOR	8	
FOP-7-1	6	HZV5-32824-003	PLUG, OUTER CONNECTOR	3	
FOP-7-1	7	HZZ3-35100-R11	SWITCH ASSY., COMBINATION	1	
FOP-7-1	8	HZV5-36180-033	SWITCH ASSY., EMERGENCY STOP	1	
FOP-7-1	9	HZV4-36182-651	CORD COMP., EMERGENCY	1	
FOP-7-1	10	HZV4-36187-652	CLIP, EMERGENCY LOCK	1	
FOP-7-1	11	HZZ5-37210-712	LAMP ASSY., INDICATION(4-LED)	1	
FOP-7-1	12	H341-38403-672	PLATE, WINKER BUZZER	1	
FOP-7-1	13	HZV5-38410-003	BUZZER COMP., WARNING	1	
FOP-7-1	14	HZZ5-38414-003	BRACKET, BUZZER	1	
FOP-7-1	15	HZW5-90109-000	SCREW, PAN, 5X40	4	
FOP-7-1	16	H921-90302-000	NUT, HEX., 16MM	1	
FOP-7-1	17	HSC2-90649-003	BAND, WIRE HARNESS(NATURAL)	1	(150MM)
FOP-7-1	18	HCO-94103-05400	WASHER, PLAIN, 5MM	4	
FOP-7-1	19	HCO-94111-05400	WASHER, SPRING, 5MM	4	

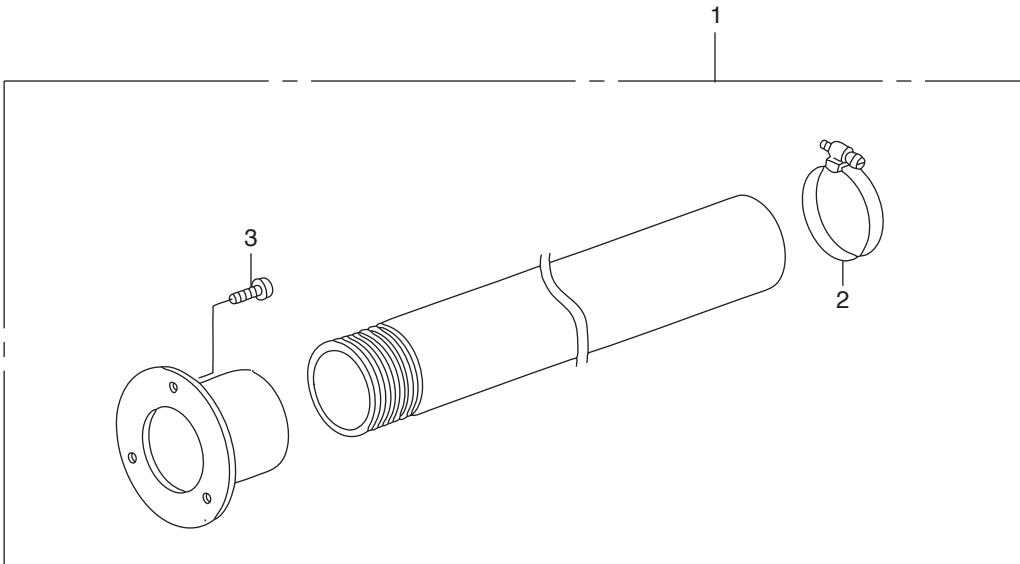





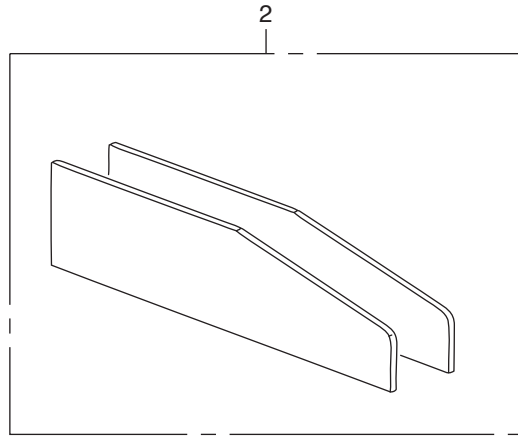
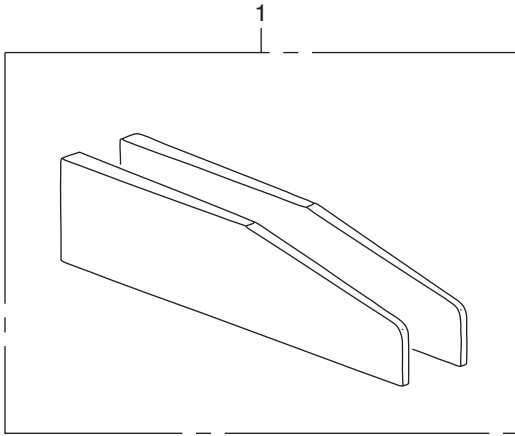



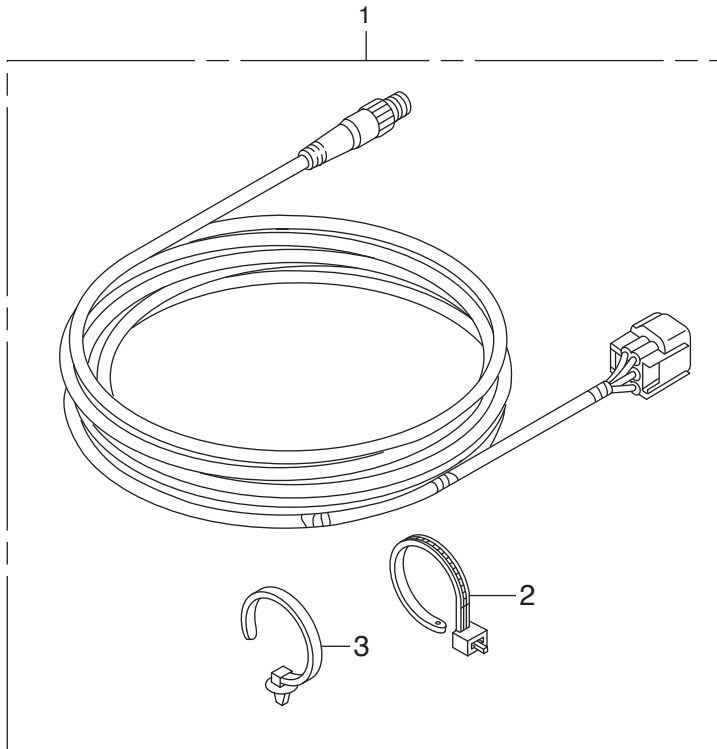



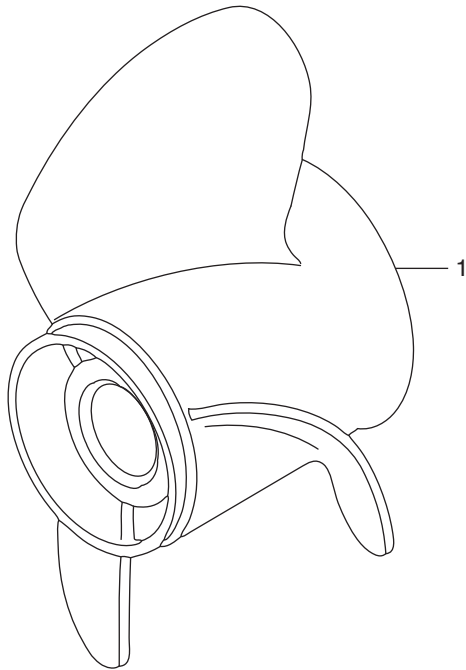



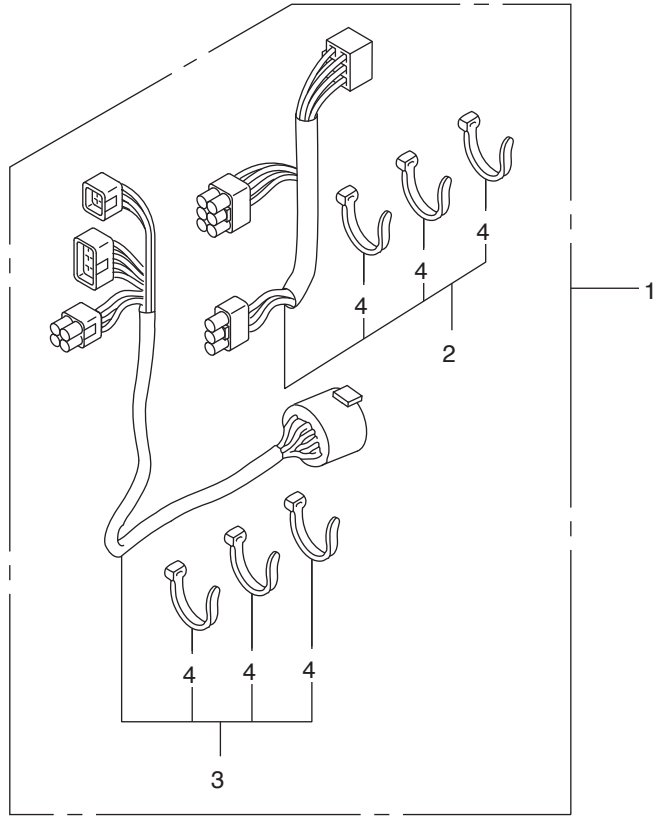





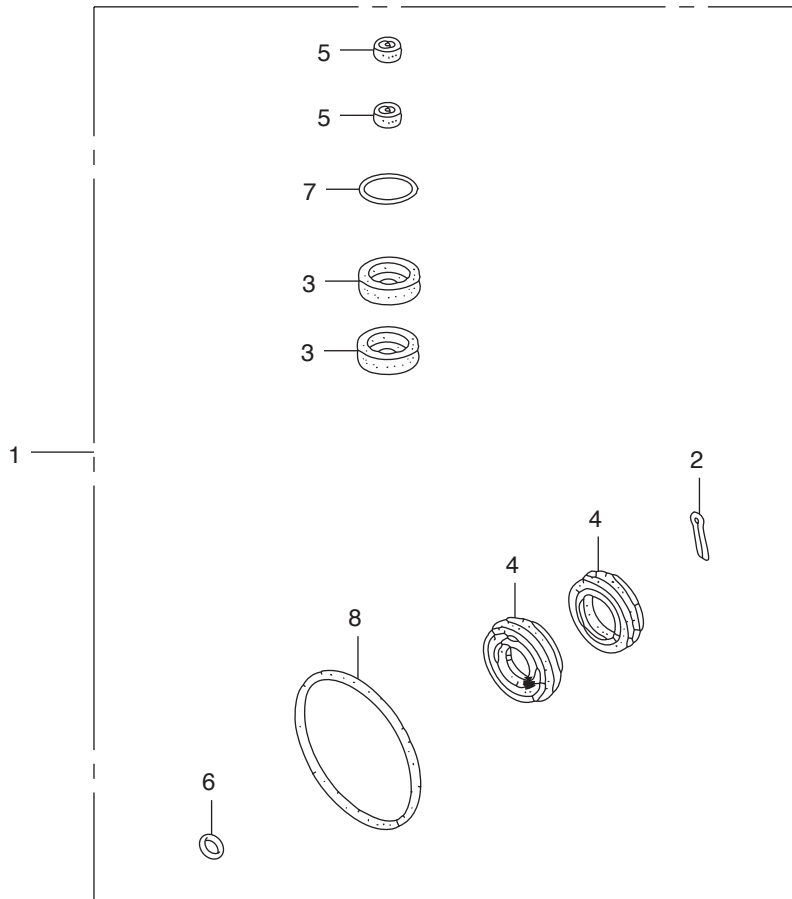



# INDEX

<A>			
ARM ASSY., INTAKE ROCKER.....	E-9-10-4	BOLT, FLANGE, 10X55.....	E-3-10-10
ARM COMP. A, EX. ROCKER.....	E-9-10-5	BOLT, FLANGE, 10X70.....	E-6-20-11
ARM COMP. B, EX. ROCKER.....	E-9-10-6	BOLT, FLANGE, 10X90.....	E-19-21
ARM COMP., LINK JOINT.....	FOP-1-6-18	BOLT, FLANGE, 10X90.....	E-21-19
ARM COMP., SHIFT LINK.....	FOP-1-6-14	BOLT, FLANGE, 12X120.....	E-6-20-12
ARM, FUEL PUMP ROCKER.....	E-9-10-3	BOLT, FLANGE, 12X95.....	E-3-28
ARM, NEUTRAL LOCK.....	FOP-1-4-5	BOLT, FLANGE, 5X10.....	E-14-10-17
ARM, SHIFT.....	F-2-9	BOLT, FLANGE, 5X14.....	E-13-10-9
ARM, THROTTLE.....	F-2-3	BOLT, FLANGE, 6X10.....	E-14-22
ARMATURE COMP.....	F-11-7	BOLT, FLANGE, 6X10.....	E-18-1-25
<B>		BOLT, FLANGE, 6X10.....	E-20-10-8
BAG, TOOL, 200MM.....	F-13-13	BOLT, FLANGE, 6X10.....	F-7-10-15
BALL, STEEL.....	E-21-6	BOLT, FLANGE, 6X11.....	F-2-24
BALL, STEEL, #12(3/8).....	F-5-33	BOLT, FLANGE, 6X12.....	E-18-51
BALL, STEEL, #7(7/32).....	F-5-32	BOLT, FLANGE, 6X12.....	E-18-1-26
BAND.....	E-18-42	BOLT, FLANGE, 6X12.....	F-2-26
BAND(BLACK 3.5X140).....	F-11-3	BOLT, FLANGE, 6X12.....	F-7-3
BAND(BLACK 3.5X140).....	FOP-1-6-40	BOLT, FLANGE, 6X12.....	F-7-10-14
BAND, AIR FLOW.....	E-15-8	BOLT, FLANGE, 6X12.....	F-8-10-29
BAND, TUBE CLIP, 12.5MM.....	F-8-20-4	BOLT, FLANGE, 6X12.....	F-10-37
BAND, UNDER CASE GROMMET.....	F-8-10-4	BOLT, FLANGE, 6X14.....	E-3-35
BAND, WIRE.....	F-10-6	BOLT, FLANGE, 6X14.....	E-5-21
BAND, WIRE.....	F-10-76	BOLT, FLANGE, 6X14.....	E-14-21
BAND, WIRE HARNESS.....	F-7-10-20	BOLT, FLANGE, 6X14.....	E-18-50
BAND, WIRE HARNESS(NATURAL).....	FOP-7-20	BOLT, FLANGE, 6X14.....	F-8-10-27
BAND, WIRE HARNESS(NATURAL).....	FOP-7-1-17	BOLT, FLANGE, 6X14(CT200).....	E-1-16
BASE.....	FOP-1-4-15	BOLT, FLANGE, 6X14(CT200).....	E-13-20
BASE COMP., TIMING BELT.....	E-13-10	BOLT, FLANGE, 6X14(CT200).....	F-2-22
BASE, L. INJECTOR.....	E-14-13	BOLT, FLANGE, 6X16.....	E-3-33
BASE, R. INJECTOR.....	E-14-11	BOLT, FLANGE, 6X16.....	E-13-23
BEARING A, CONNECTING ROD.....	E-7-8	BOLT, FLANGE, 6X16.....	E-18-49
BEARING A, MAIN LOWER(BLACK).....	E-7-12	BOLT, FLANGE, 6X16.....	E-19-23
BEARING A, MAIN UPPER(BLACK).....	E-7-10	BOLT, FLANGE, 6X16.....	F-2-23
BEARING B, CONNECTING ROD.....	E-7-7	BOLT, FLANGE, 6X16.....	F-4-18
BEARING B, MAIN LOWER(BROWN).....	E-7-7	BOLT, FLANGE, 6X18.....	E-3-36
BEARING B, MAIN UPPER(BROWN).....	E-7-7	BOLT, FLANGE, 6X18.....	E-5-22
BEARING C, CONNECTING ROD.....	E-7-7	BOLT, FLANGE, 6X20.....	E-20-10-9
BEARING C, MAIN LOWER(GREEN).....	E-7-7	BOLT, FLANGE, 6X20.....	F-7-20-7
BEARING C, MAIN UPPER(GREEN).....	E-7-7	BOLT, FLANGE, 6X20.....	F-8-11
BEARING D, CONNECTING ROD.....	E-7-7	BOLT, FLANGE, 6X20.....	F-8-10-30
BEARING D, MAIN LOWER(YELLOW).....	E-7-7	BOLT, FLANGE, 6X20.....	F-10-34
BEARING D, MAIN UPPER(YELLOW).....	E-7-7	BOLT, FLANGE, 6X20.....	F-10-40
BEARING E, CONNECTING ROD.....	E-7-7	BOLT, FLANGE, 6X22.....	E-3-37
BEARING E, MAIN LOWER(PINK).....	E-7-7	BOLT, FLANGE, 6X22.....	E-3-10-8
BEARING E, MAIN UPPER(PINK).....	E-7-7	BOLT, FLANGE, 6X22.....	E-6-10-24
BEARING F, MAIN LOWER(RED).....	E-7-7	BOLT, FLANGE, 6X22.....	E-13-24
BEARING F, MAIN UPPER(RED).....	E-7-7	BOLT, FLANGE, 6X22.....	E-14-10-15
BEARING, FR. GENERATOR.....	E-19-3	BOLT, FLANGE, 6X22.....	E-15-21
BEARING, NEEDLE, 20X28X13.....	E-6-10-34	BOLT, FLANGE, 6X23.....	F-10-35
BEARING, NEEDLE, 28X39X30.....	F-5-26	BOLT, FLANGE, 6X25.....	E-14-19
BEARING, NEEDLE, 30.5X47X37.....	F-4-25	BOLT, FLANGE, 6X25.....	E-18-48
BEARING, NEEDLE, 32X42X30.....	F-5-27	BOLT, FLANGE, 6X32.....	E-3-10-9
BEARING, RADIAL BALL.....	F-5-25	BOLT, FLANGE, 6X32.....	E-6-10-25
BEARING, RR. GENERATOR.....	E-19-2	BOLT, FLANGE, 6X32.....	E-14-10-16
BEARING, TAPER ROLLER.....	F-4-26	BOLT, FLANGE, 6X35.....	E-1-17
BEARING, TAPER ROLLER.....	F-5-24	BOLT, FLANGE, 6X35.....	E-3-34
BEARING, THRUST(F).....	F-5-23	BOLT, FLANGE, 6X35.....	E-4-16
BELT, A.C. GENERATOR.....	E-13-17	BOLT, FLANGE, 6X35.....	E-14-20
BELT, TIMING(197YU26 B-333).....	E-13-6	BOLT, FLANGE, 6X37.....	E-3-10-11
BLOCK ASSY., CYLINDER.....	E-3-3	BOLT, FLANGE, 6X40.....	E-6-10-31
BLOCK, NEUTRAL LOCK.....	FOP-1-6-6	BOLT, FLANGE, 6X55.....	E-3-10-14
BLOCK, THROTTLE FRICTION.....	FOP-1-6-28	BOLT, FLANGE, 6X60.....	E-4-18
BODY.....	E-18-3	BOLT, FLANGE, 6X60.....	E-15-22
BODY, OIL JET.....	E-3-13	BOLT, FLANGE, 8X100.....	E-6-10-27
BOLT A, THROUGH.....	E-21-14	BOLT, FLANGE, 8X18.....	F-7-10-16
BOLT COMP., OIL JET.....	E-3-14	BOLT, FLANGE, 8X20.....	E-9-12
BOLT KIT, SIDE REMOTE CONTROL.....	FOP-5-1	BOLT, FLANGE, 8X22.....	F-8-10-31
BOLT, 1/4-28UNF.....	F-10-36	BOLT, FLANGE, 8X25.....	E-3-10-15
BOLT, 12MM.....	E-5-13	BOLT, FLANGE, 8X28.....	E-9-13
BOLT, 3/8-24UNF.....	F-10-43	BOLT, FLANGE, 8X30.....	E-5-23
BOLT, CONNECTING ROD.....	E-7-6	BOLT, FLANGE, 8X30.....	E-6-10-29
BOLT, COVER LOCK.....	F-8-12	BOLT, FLANGE, 8X30.....	E-9-10-18
BOLT, DRAIN PLUG.....	E-6-11	BOLT, FLANGE, 8X32.....	E-1-18
BOLT, DRAIN PLUG.....	F-3-14	BOLT, FLANGE, 8X35.....	E-18-52
BOLT, FLANGE, 10X110.....	E-21-20	BOLT, FLANGE, 8X35.....	FOP-1-6-50
BOLT, FLANGE, 10X120(SATO).....	E-6-20-2	BOLT, FLANGE, 8X40.....	E-4-19
BOLT, FLANGE, 10X40.....	E-13-26	BOLT, FLANGE, 8X40.....	E-9-10-19
BOLT, FLANGE, 10X43.....	E-13-27	BOLT, FLANGE, 8X45.....	E-1-19
		BOLT, FLANGE, 8X50.....	E-3-40
		BOLT, FLANGE, 8X50.....	E-14-10-18
		BOLT, FLANGE, 8X60.....	E-4-17
		BOLT, FLANGE, 8X65.....	E-15-23
		BOLT, FLANGE, 8X75.....	E-3-38
		BOLT, FRICTION.....	FOP-1-6-29
		BOLT, HEX.....	F-11-34
		BOLT, HEX., 10X235.....	F-10-41
		BOLT, HEX., 10X35.....	F-3-20-32
		BOLT, HEX., 10X60.....	E-6-20-6
		BOLT, HEX., 10X85.....	E-6-20-5
		BOLT, HEX., 12X120.....	E-6-20-3
		BOLT, HEX., 12X130.....	F-10-46
		BOLT, HEX., 12X200.....	F-10-39
		BOLT, HEX., 12X45.....	F-5-13
		BOLT, HEX., 12X50.....	F-3-20-37
		BOLT, HEX., 12X65.....	E-6-20-4
		BOLT, HEX., 14X180.....	F-3-20-33
		BOLT, HEX., 5X16.....	FOP-1-6-69
		BOLT, HEX., 6X14.....	F-10-42
		BOLT, HEX., 6X16.....	E-6-10
		BOLT, HEX., 6X16.....	F-2-27
		BOLT, HEX., 6X55.....	F-3-26
		BOLT, HEX., 8X28.....	E-6-9
		BOLT, HEX., 8X35.....	E-6-8
		BOLT, HEX., 8X35.....	F-8-10-26
		BOLT, IDLER.....	E-13-13
		BOLT, OIL CHECK.....	F-3-10
		BOLT, RECESSED.....	F-11-31
		BOLT, SEALING, 18MM.....	E-5-10
		BOLT, SEALING, 22MM.....	E-3-6
		BOLT, SEALING, 22MM.....	E-3-39
		BOLT, SEALING, 22MM.....	E-3-10-12
		BOLT, SEALING, 22MM.....	E-5-25
		BOLT, SEALING, 6MM.....	E-18-46
		BOLT, SOCKET(A).....	F-11-32
		BOLT, SOCKET(B).....	F-11-33
		BOLT, SOCKET, 6X16.....	F-8-13
		BOLT, SPECIAL ADJUSTER.....	E-19-22
		BOLT, SPECIAL, 6X12.....	F-3-20-38
		BOLT, SPECIAL, 6X17.....	F-3-20-35
		BOLT, SPECIAL, 6X22.....	F-3-20-36
		BOLT, SPECIAL, 6X220.....	FOP-5-2
		BOLT, SPECIAL, 6X37.....	F-3-20-39
		BOLT, SPECIAL, 8MM.....	E-5-14
		BOLT, SPECIAL, 8X29.....	E-13-10-8
		BOLT, STUD, 10X45.....	E-6-10-26
		BOLT, STUD, 12X40.....	F-3-15
		BOLT, STUD, 6X68.....	E-19-8
		BOLT, STUD, 8X28.....	E-14-23
		BOLT, STUD, 8X45.....	E-14-24
		BOLT, TENSIONER.....	E-19-24
		BOLT, TIMING BELT ADJUSTING.....	E-13-21
		BOLT, TIMING BELT COVER.....	E-13-10-7
		BOLT, TIMING BELT IDLER A.....	E-13-14
		BOLT, WASHER, 6X121.....	E-6-10-28
		BOLT, WASHER, 8X60.....	F-4-17
		BOLT-WASHER, 10X109.....	E-3-29
		BOLT-WASHER, 10X32.....	F-3-12
		BOLT-WASHER, 10X32.....	F-10-38
		BOLT-WASHER, 10X47.....	F-3-13
		BOLT-WASHER, 10X60.....	E-3-30
		BOLT-WASHER, 10X80.....	E-3-31
		BOLT-WASHER, 11X105.....	E-3-32
		BOLT-WASHER, 12X163.....	E-9-11
		BOLT-WASHER, 12X35.....	E-13-25
		BOLT-WASHER, 16X49.....	E-13-22
		BOLT-WASHER, 5X18.....	E-14-10-15
		BOLT-WASHER, 5X30.....	E-15-20
		BOLT-WASHER, 6X16.....	F-2-25
		BOLT-WASHER, 6X25.....	E-15-19
		BOLT-WASHER, 6X25.....	F-3-20-31
		BOLT-WASHER, 6X25.....	F-7-10-13
		BOLT-WASHER, 6X27.....	E-20-4
		BOLT-WASHER, 6X27(CT200).....	E-20-10-7
		BOLT-WASHER, 6X27(CT200).....	F-7-10-12
		BOLT-WASHER, 6X29.....	E-6-10-30
		BOLT-WASHER, 8X35.....	E-18-47
		BOSS, FLYWHEEL.....	E-5-12
		BOX ASSY., JUNCTION.....	F-7-20-1

BOX ASSY., REMOTE CONTROL(EU).....	FOP-1-6-1	CAP, TIMING BELT TENSIONER.....	E-13-8	CLUTCH COMP., OVERRUNNING.....	E-21-3
BOX ASSY., REMOTE CONTROL(EU).....	FOP-1-6-	CAP, UNDER COVER.....	F-3-20-24	CLUTCH COMP., OVERRUNNING.....	E-21-
BOX KIT, REMOTE CONTROL.....	FOP-1-1	CAP, WATER JOINT.....	F-3-20-4	COCK ASSY., FUEL DRAIN.....	E-18-1-24
BOX KIT, REMOTE CONTROL.....	FOP-1-2-1	CARTRIDGE, OIL FILTER.....	E-3-10-4	COIL COMP., PLUG HOLE.....	E-20-2
BOX KIT, REMOTE CONTROL.....	FOP-1-4-1	CASE ASSY., GEAR(XL).....	F-3-10-1	COLLAR.....	E-18-23
BRACKET A, RR. COVER.....	F-8-10-8	CASE ASSY., OIL SEAL.....	E-3-2	COLLAR.....	E-18-26
BRACKET ASSY.....	F-11-6	CASE COMP., MOUNT.....	E-6-10-22	COLLAR, 8.5X14.5.....	E-18-56
BRACKET B, HARNESS CLIP.....	E-3-22	CASE COMP., PUMP.....	E-18-27	COLLAR, 8.5X14.5.....	F-8-10-38
BRACKET B, RR. COVER.....	F-8-10-9	CASE KIT, GEAR.....	FOP-14-1	COLLAR, C.D.I. UNIT CASE.....	E-15-26
BRACKET C, COUPLER.....	F-7-10-2	CASE, ELECTRONIC PARTS.....	E-20-10-1	COLLAR, C.D.I. UNIT CASE.....	E-20-5
BRACKET C, HARNESS CLIP.....	E-1-12	CASE, EXTENSION.....	F-3-20-10	COLLAR, C.D.I. UNIT CASE.....	E-20-10-11
BRACKET, A.C. GENERATOR FUSE.....	E-20-10-3	CASE, FLUSH VALVE.....	E-6-10-7	COLLAR, C.D.I. UNIT CASE.....	F-7-10-25
BRACKET, BUZZER.....	FOP-7-17	CASE, GEAR.....	F-3-3	COLLAR, DISTANCE.....	F-4-33
BRACKET, BUZZER.....	FOP-7-1-14	CASE, POWER TILT RELAY.....	F-7-10-11	COLLAR, DISTANCE(A).....	FOP-5-3
BRACKET, CABLE.....	F-8-10-1	CASE, SWIVEL.....	F-10-20	COLLAR, DISTANCE(B).....	FOP-5-4
BRACKET, CLIP B.....	E-1-11	CIRCLIP, EXTERNAL, 15MM.....	F-5-31	COLLAR, DISTANCE, 6.5X9X3.....	F-8-16
BRACKET, CLIP B.....	E-3-21	CIRCLIP, EXTERNAL, 39MM.....	F-10-66	COLLAR, DISTANCE, 6.5X9X5.....	F-3-20-52
BRACKET, COUPLER D.....	E-13-18	CIRCLIP, INTERNAL.....	F-11-38	COLLAR, DISTANCE, 6X10.5X25.....	F-3-20-53
BRACKET, ECU.....	E-20-10-5	CIRCLIP, INTERNAL, 43.....	F-3-20-48	COLLAR, DISTANCE, 6X10X43.5.....	FOP-1-6-68
BRACKET, FR.....	E-21-10	CIRCLIP, INTERNAL, 47MM.....	F-4-37	COLLAR, LINK JOINT.....	FOP-1-6-67
BRACKET, FR. COVER.....	F-8-10-5	CLAMP.....	F-6-5	COLLAR, LOWER CYLINDER.....	F-10-33
BRACKET, HARNESS CLIP A.....	E-14-17	CLAMP.....	F-6-8	COLLAR, MOUNTING(6MM).....	F-7-10-23
BRACKET, HOOK.....	F-8-4	CLAMP.....	FOP-8-2	COLLAR, ORIFICE.....	F-11-50
BRACKET, L. SIDE COVER.....	F-8-10-7	CLAMP, CHECK VALVE.....	E-18-10-2	COLLAR, SHIFT SLIDER.....	F-2-11
BRACKET, L. STERN.....	F-10-25	CLAMP, FUEL TUBE.....	E-18-10-23	COLLAR, SLIDING PLATE.....	FOP-1-6-16
BRACKET, LINK JOINT.....	FOP-1-6-19	CLAMP, HARNESS.....	FOP-1-6-9	COLLAR, STEERING ROD.....	F-10-71
BRACKET, NEUTRAL SWITCH.....	F-2-19	CLAMP, HOSE.....	E-18-10-10	COLLAR, TIMING BELT COVER.....	E-13-10-10
BRACKET, R. SIDE COVER.....	F-8-10-6	CLAMP, POWER TILT CORD.....	FOP-1-6-31	CONTROL UNIT, ELECTRONIC.....	E-20-10-4
BRACKET, R. STERN.....	F-10-24	CLAMP, TUBE.....	F-10-21	CORD ASSY., INDICATOR(20FT).....	FOP-13-2
BRACKET, REMOTE CONTROL.....	FOP-1-12	CLAMP, TUBE(D10.5).....	E-4-20	CORD ASSY., INDICATOR(25FT).....	FOP-13-
BRACKET, REMOTE CONTROL.....	FOP-1-2-13	CLAMP, TUBE(D10.5).....	E-18-10-26	CORD ASSY., INDICATOR(30FT).....	FOP-13-
BRACKET, RR.....	E-21-11	CLAMP, TUBE(D10.7).....	E-18-10-19	CORD COMP., EMERGENCY.....	FOP-1-6-42
BRACKET, SENSOR CORD.....	E-14-10-8	CLAMP, TUBE(D12).....	E-1-21	CORD COMP., EMERGENCY.....	FOP-7-11
BRACKET, SHIFT LINK.....	F-2-16	CLAMP, TUBE(D12).....	E-18-10-20	CORD COMP., EMERGENCY.....	FOP-7-1-9
BRACKET, SOLENOID VALVE.....	E-1-6	CLAMP, TUBE(D21).....	E-4-22	CORD, A.C. GENERATOR.....	F-7-10-8
BRACKET, TILTING.....	F-10-28	CLAMP, TUBE(D29).....	E-4-21	CORD, SWITCH.....	E-3-23
BREAKER ASSY.....	F-11-1	CLAMP, TUBE(D32.5).....	E-1-22	COTTER, VALVE(FUJI VALVE).....	E-9-10-17
BRUSH ASSY.....	F-11-2	CLAMP, WIRE, 8MM.....	E-18-1-30	COVER ASSY.....	FOP-1-4-11
BRUSH SET.....	E-21-7	CLAMPER, SENSOR TUBE.....	F-10-12	COVER ASSY., DRAIN FAN.....	E-15-29
BRUSH SET.....	E-21-	CLIP A, WIRE.....	E-1-13	COVER ASSY., CRANKCASE UPPER.....	E-3-1
BUFFER, PLATE.....	E-18-1-6	CLIP D, SPEEDOMETER CABLE.....	E-14-18	COVER ASSY., ENGINE.....	F-8-2
BUSH A, COVER LOCK.....	F-8-10-15	CLIP D, WASHER TUBE.....	E-1-29	COVER ASSY., L. TIMING BELT.....	E-13-10-3
BUSH A, THRUST RECEIVE.....	F-10-31	CLIP, 10.7MM.....	F-11-37	COVER ASSY., R. TIMING BELT.....	E-13-10-2
BUSH B, COVER LOCK.....	F-8-10-16	CLIP, BRAKE PIPE.....	F-2-21	COVER B, TERMINAL.....	F-7-10-6
BUSH B, THRUST RECEIVE.....	F-10-32	CLIP, EMERGENCY LOCK.....	FOP-1-6-43	COVER B, TERMINAL(L).....	F-7-10-5
BUSH COMP., VERTICAL SHAFT.....	F-3-20-12	CLIP, EMERGENCY LOCK.....	FOP-7-12	COVER COMP.....	E-18-4
BUSH, INSULATION.....	E-19-4	CLIP, EMERGENCY LOCK.....	FOP-7-1-10	COVER COMP., FUSE.....	F-7-20-2
BUSH, INSULATION.....	E-19-18	CLIP, HARNESS.....	E-1-24	COVER COMP., INTAKE MANIFOLD.....	E-14-10-5
BUSH, LOWER CYLINDER.....	F-11-27	CLIP, HARNESS.....	E-18-54	COVER COMP., L. UNDER ENGINE.....	F-3-20-21
BUSH, MOTOR CODE.....	F-11-21	CLIP, HARNESS.....	F-8-10-36	COVER COMP., R. UNDER ENGINE.....	F-3-20-20
BUSH, SHIFT ARM.....	F-2-15	CLIP, HARNESS BAND(BLACK).....	E-3-50	COVER, BEARING.....	E-19-5
BUSH, SWIVEL CASE.....	F-10-23	CLIP, HARNESS BAND(BLACK).....	E-13-10-11	COVER, DRAIN PLUG(XL).....	F-3-20-13
BUSH, SWIVEL CASE.....	F-11-12	CLIP, HARNESS BAND(BLACK).....	F-2-41	COVER, DUAL GRIP.....	FOP-1-2-8
BUSH, TILT ARM.....	F-10-27	CLIP, HARNESS BAND(BLACK).....	F-7-5	COVER, FLUSH VALVE.....	E-6-10-6
BUTTON, THROTTLE.....	FOP-1-9	CLIP, HARNESS BAND(BLACK).....	F-7-10-24	COVER, FR.....	F-8-6
BUTTON, THROTTLE.....	FOP-1-2-10	CLIP, HARNESS BAND(BLACK).....	F-8-10-37	COVER, FR. SEPARATE.....	F-3-20-9
BUTTON, THROTTLE.....	FOP-1-4-8	CLIP, HARNESS BAND(BLACK).....	FOP-10-3	COVER, GRIP.....	FOP-1-4-4
BUZZER COMP., WARNING.....	FOP-1-6-46	CLIP, INJECTOR.....	E-14-2	COVER, IMPELLER.....	F-4-4
BUZZER COMP., WARNING.....	FOP-7-16	CLIP, PISTON PIN.....	E-7-4	COVER, L. CAMSHAFT THRUST.....	E-9-8
BUZZER COMP., WARNING.....	FOP-7-1-13	CLIP, SENSOR HOSE.....	E-1-14	COVER, L. CYLINDER HEAD.....	E-1-3
<C>		CLIP, SHIFT WIRE.....	E-1-15	COVER, L. GRIP.....	FOP-1-5
CABLE ASSY., POWER TILT RELAY.....	F-7-10-7	CLIP, TUBE.....	E-6-10-1	COVER, L. GRIP.....	FOP-1-2-6
CABLE ASSY., REMOTE CONTROL(B).....	FOP-1-6-34	CLIP, TUBE.....	E-18-1-1	COVER, L. LOWER MOUNTING.....	F-3-20-27
CABLE ASSY., STARTER.....	F-7-10-3	CLIP, TUBE.....	E-18-10-11	COVER, L. RELIEF VALVE.....	E-6-10-17
CABLE ASSY., SWITCH PANEL.....	FOP-13-3	CLIP, TUBE(B10).....	E-6-10-32	COVER, L. WATER JACKET.....	E-6-10-21
CABLE ASSY., SWITCH PANEL.....	FOP-13-	CLIP, TUBE(B12).....	E-1-23	COVER, LOCK ARM.....	FOP-1-4-6
CABLE ASSY., SWITCH PANEL.....	FOP-13-	CLIP, TUBE(B12).....	E-18-1-28	COVER, NEUTRAL SWITCH.....	F-2-20
CABLE COMP. A, COVER LOCK.....	F-8-10-12	CLIP, TUBE(B12.5).....	E-6-10-33	COVER, OIL LEVEL GAUGE.....	E-3-16
CABLE COMP. B, COVER LOCK.....	F-8-10-13	CLIP, TUBE(B12.5).....	E-18-1-29	COVER, OIL PUMP.....	E-5-4
CABLE COMP., THROTTLE.....	E-15-10	CLIP, TUBE(B12.5).....	F-3-20-47	COVER, PLUG MAINTENANCE.....	F-3-20-19
CABLE SET, PANEL INDICATOR.....	FOP-13-1	CLIP, TUBE(B8).....	E-18-1-27	COVER, PUMP.....	E-18-28
CABLE SET, PANEL INDICATOR.....	FOP-13-	CLIP, TUBE(B8).....	F-10-65	COVER, PUMP(A).....	E-18-29
CABLE SET, PANEL INDICATOR.....	FOP-13-	CLIP, WIRE.....	E-18-10-22	COVER, R. CAMSHAFT THRUST.....	E-9-7
CAMSHAFT, L.....	E-9-10-2	CLIP, WIRE HARNESS.....	E-18-1-32	COVER, R. CYLINDER HEAD.....	E-1-1
CAMSHAFT, R.....	E-9-10-1	CLIP, WIRE HARNESS.....	F-7-4	COVER, R. LOWER MOUNTING.....	F-3-20-26
CAP COMP., OIL TANK.....	F-11-30	CLIP, WIRE HARNESS.....	F-7-10-21	COVER, R. RELIEF VALVE.....	E-6-10-13
CAP, BOLT, 10MM.....	E-3-10-13	CLIP, WIRE HARNESS.....	F-7-10-22	COVER, R. WATER JACKET.....	E-6-10-19
CAP, GRIP.....	FOP-1-7	CLIP, WIRE HARNESS.....	F-10-67	COVER, STARTER TERMINAL.....	F-7-10-4
CAP, GRIP.....	FOP-1-2-9	CLIP, WIRE HARNESS(6.3MM).....	FOP-1-6-66	COVER, THERMOSTAT.....	E-4-13
CAP, HANDLE.....	FOP-1-6-5	CLIP, WIRE HARNESS, 10MM.....	E-14-26	COVER, UPPER MOUNT.....	F-10-18
CAP, L. SIDE COVER.....	F-8-10-24	CLIP, WIRE HARNESS, 25MM.....	E-18-1-31	COVER, WATER JACKET.....	E-18-12
CAP, OIL(YELLOW).....	E-3-10-5	CLIP, WIRE HARNESS, 25MM.....	E-20-10-10	CRANKCASE COMP.....	E-3-10-1
CAP, SWITCH.....	FOP-1-8	CLIP, WIRE HARNESS, 25MM.....	F-3-20-49	CRANKSHAFT COMP.....	E-7-9

CUP	E-18-1-16	GROMMET, RELAY	F-7-10-10	<K>	
CUP SET, WATER SEPARATOR	E-18-1-5	GROMMET, RELAY BRACKET	E-20-10-6	KEY, 4.5X24	E-13-28
<D>		GROMMET, SILENCER	E-15-9	KEY, SPECIAL	E-13-29
DAMPER, HOOK	F-8-5	GROMMET, TIMING BELT COVER	E-13-10-1	KEY, WOODRUFF	F-4-23
DOWEL PIN, 10X12	E-14-30	GROMMET, UNDER CASE	E-15-18	KIT, CABLE(NMEA)(6FT)	FOP-10-1
DOWEL PIN, 13X37	E-3-41	GROMMET, UNDER CASE(C)	F-3-20-7	<L>	
DOWEL PIN, 14X15	E-5-15	GROMMET, UNDER CASE(C)	F-11-10	LABEL, FUSE & OIL CAUTION	F-12-2
DOWEL PIN, 14X15	E-6-20-9	GROMMET, VAPOR SEPARATOR	E-18-34	LABEL, WARNING OPERATOR(EC)	F-12-10
DOWEL PIN, 16X22	E-9-15	GROMMET, VAPOR SEPARATOR	E-18-35	LABEL, WARNING OPERATOR(EU)	F-12-13
DOWEL PIN, 5X8	E-3-54	GROMMET, WATER CHECK	F-3-20-30	LAMP ASSY., INDICATION	FOP-1-6-44
DOWEL PIN, 6X10	E-3-53	GROMMET, WATER TUBE	E-6-6	LAMP ASSY., INDICATION(4-LED)	FOP-7-14
DOWEL PIN, 6X10	E-9-14	GUIDE COMP., ROD	F-11-18	LAMP ASSY., INDICATION(4-LED)	FOP-7-1-11
DOWEL PIN, 6X10	E-9-18	GUIDE, EX. VALVE(OS)	E-9-3	LEVER SET	E-21-18
DOWEL PIN, 6X10	E-13-30	GUIDE, IN. VALVE(OS)	E-9-2	LEVER, COVER LOCK	F-8-10-14
DOWEL PIN, 6X10	E-15-28	GUIDE, L. EX.	E-6-10-5	LEVER, HANDLE LOCK	FOP-1-6-3
DOWEL PIN, 6X10	F-3-24	GUIDE, R. EX.	E-6-10-2	LEVER, IDLE	FOP-1-6-22
DOWEL PIN, 6X10	F-3-20-50	<H>		LINER, PUMP	F-4-3
DOWEL PIN, 6X10	F-4-24	HANDLE, REMOTE CONTROL	FOP-1-4	LINER, SWIVEL CASE	F-10-22
DOWEL PIN, 8X14	E-3-10-18	HANDLE, REMOTE CONTROL	FOP-1-2-5	LOCK ASSY., FR.	F-8-10-22
DRIVER 3, MINUS SCREW(NO.2)	F-13-15	HANDLE, REMOTE CONTROL	FOP-1-4-3	LOCK COMP., SIDE	F-8-10-23
<E>		HANDLE, REMOTE CONTROL	FOP-1-6-2	<M>	
END COVER, RR	E-19-17	HANGER, ENGINE	E-3-10-2	MANIFOLD COMP., INTAKE	E-14-10-3
END, NIPPLE	F-10-10	HANGER, ENGINE	E-9-1	MANIFOLD COMP., L. EX.	E-4-4
E-RING, 10MM	F-4-34	HARNASS ASSY., MAIN WIRE	F-7-1	MANIFOLD COMP., R. EX.	E-4-2
E-RING, 12MM	F-2-43	HARNASS ASSY., SWITCH PANEL	FOP-7-6	MARK, FAST IDLE	FOP-1-6-49
E-RING, 15MM	F-11-51	HARNASS ASSY., SWITCH PANEL	FOP-7-1-4	MARK, FLUSH MOUNT	FOP-1-4-19
E-RING, 3MM	FOP-1-6-78	HARNASS COMP.	E-18-41	MARK, FR. EMBLEM(TOHATSU)	F-12-16
E-RING, 4MM	F-2-42	HEAD COMP., CYLINDER	E-9-5	MARK, HANDLE FLUSH MOUNT	FOP-1-4-18
E-RING, 4MM	FOP-1-6-79	HOLDER	E-18-11	MARK, L. SIDE STRIPE	F-12-15
E-RING, 6MM	F-8-10-39	HOLDER ASSY., BRUSH	E-19-1	MARK, OPERATOR CAUTION	F-12-9
E-RING, 6MM	FOP-1-36	HOLDER COMP., BRUSH	E-21-9	MARK, R. SIDE STRIPE	F-12-4
E-RING, 6MM	FOP-1-2-41	HOLDER COMP., BRUSH	E-21-	MARK, REMOTE CONTROL(DUAL)	FOP-1-2-24
E-RING, 6MM	FOP-1-4-28	HOLDER, BEARING	F-5-12	MARK, REMOTE CONTROL(SINGLE)	FOP-1-21
E-RING, 7MM	FOP-1-6-80	HOLDER, NEUTRAL LOCK	FOP-1-4-14	MARK, RR.(BFT250)	F-12-3
EXTENSION, OIL FILLER	E-3-10-6	HOLDER, OIL FILTER	E-3-10-7	MESH, FUEL FILTER	E-14-4
<F>		HOLDER, PROPELLER SHAFT	F-5-11	METAL COMP., ANODE	F-3-9
FAN, COOLING	E-13-16	HOLDER, ROD(A)	F-8-20-3	METAL KIT, ANODE	F-10-1
FILTER	E-18-1-12	HOLDER, SEAL	F-2-17	METAL, ANODE	E-3-4
FILTER ASSY., SPOOL VALVE	E-3-19	HOLDER, SHIFT ROD	F-4-12	METAL, ANODE	E-3-5
FILTER B	F-11-19	HOLDER, STRIKER	F-8-10-21	METAL, ANODE	E-4-1
FLOAT	E-18-1-15	HOSE	F-6-6	METER LEAD WIRE	FOP-3-6
FLOAT SET	E-18-2	HOSE	F-6-7	MOTION COMP., LOST	E-9-10
FLYWHEEL COMP.	E-5-11	HOSE A, PRESSURE REGULATOR	E-18-10-13	MOTOR ASSY., POWER TILT	F-11-5
FRAME COMP., MOUNTING(XL)	F-10-13	HOSE B, PRESSURE REGULATOR	E-18-10-14	MOTOR ASSY., STARTER	E-21-1
FUSE, BLOCK(150A)	F-7-20-3	HOSE COMP., FUEL	E-14-9	MOUNT COMP., LOWER RUBBER	F-3-20-17
FUSE, MINI(10A)	F-7-20-9	HOSE COMP., FUEL JOINT	E-14-10	MOUNT COMP., UPPER RUBBER	F-10-15
FUSE, MINI(15A)	F-7-20-10	HOSE KIT, RIGGING	FOP-8-1	<N>	
FUSE, MINI(30A)	F-7-20-11	HOUSING ASSY., L. INNER	FOP-1-3	NIPPLE, GREASE	F-10-68
<G>		HOUSING ASSY., L. INNER	FOP-1-2-3	NIPPLE, SENSOR	F-10-11
GASKET B, IMPELLER	F-4-5	HOUSING ASSY., R. INNER	FOP-1-2-4	NUT, CASTLE, 18MM	F-5-14
GASKET COMP., CYLINDER HEAD	E-9-9	HOUSING ASSY., R. INNER	FOP-1-4-2	NUT, FLANGE CAP, 10MM	E-3-10-16
GASKET, EAC VALVE	E-15-5	HOUSING COMP., REMOTE CONTROL	FOP-1-13	NUT, FLANGE, 10MM	F-10-51
GASKET, EX. PIPE	E-6-4	HOUSING COMP., REMOTE CONTROL	FOP-1-2-14	NUT, FLANGE, 12MM	F-10-48
GASKET, FR. INJECTOR BASE	E-14-12	HOUSING COMP., REMOTE CONTROL	FOP-1-6-10	NUT, FLANGE, 5MM	FOP-6-2
GASKET, INTAKE MANIFOLD	E-14-15	HOUSING COMP., REMOTE CONTROL	FOP-1-6-11	NUT, FLANGE, 5MM	FOP-7-2
GASKET, INTAKE MANIFOLD	E-14-10-1	HOUSING, IMPELLER	F-4-2	NUT, FLANGE, 5MM	FOP-7-1-2
GASKET, L. EX. MANIFOLD	E-4-5	HOUSING, LEAD	FOP-1-14	NUT, FLANGE, 8MM	E-14-25
GASKET, MOUNT CASE	E-6-20-1	HOUSING, LEAD	FOP-1-2-15	NUT, FLANGE, 8MM	E-14-10-19
GASKET, R. EX. MANIFOLD	E-4-3	HOUSING, LOWER CENTER MOUNTING	F-10-17	NUT, FLANGE, 8MM	E-19-25
GASKET, RR. INJECTOR BASE	E-14-14	HOUSING, LOWER MOUNTING	F-3-20-16	NUT, HEX., 12MM	F-10-72
GASKET, THROTTLE BODY	E-15-2	HOUSING, REMOTE CONTROL BOX(C)	FOP-1-6-12	NUT, HEX., 16MM	F-3-20-41
GAUGE COMP., OIL LEVEL	E-3-15	HOUSING, UPPER MOUNTING	F-10-14	NUT, HEX., 16MM	FOP-1-6-54
GEAR ASSY., INTERNAL	E-21-16	HOUSING, WATER PUMP	F-4-6	NUT, HEX., 16MM	FOP-7-19
GEAR ASSY., PLANETARY	E-21-4	<I>		NUT, HEX., 16MM	FOP-7-1-16
GEAR ASSY.,INTERNAL	E-21-24	IDLER B, TIMING BELT	E-13-15	NUT, HEX., 18MM	F-4-20
GEAR COMP., BEVEL(FORWARD)	F-5-8	IDLER, TIMING BELT(KOYO SEIKO)	E-13-12	NUT, HEX., 20MM	F-2-28
GEAR, BEVEL(REVERSE)(24T)	F-5-9	IMPELLER, PUMP	F-4-1	NUT, HEX., 5MM	FOP-1-29
GEAR, PINION	F-4-16	INJECTOR ASSY., FUEL	E-14-1	NUT, HEX., 5MM	FOP-1-35
GENERATOR ASSY., A.C.	E-19-14	INSULATOR	E-18-31	NUT, HEX., 5MM	FOP-1-2-33
GRIP, REMOTE CONTROL HANDLE	FOP-1-6	INSULATOR COMP.	E-18-30	NUT, HEX., 5MM	FOP-1-2-34
GRIP, REMOTE CONTROL HANDLE	FOP-1-2-7	<J>		NUT, HEX., 5MM	FOP-1-2-40
GRIP, REMOTE CONTROL HANDLE	FOP-1-6-4	JOINT A, VACUUM TUBE	E-14-10-7	NUT, HEX., 5MM	FOP-1-6-77
GRIP, SCREW DRIVER	F-13-16	JOINT ASSY (INLET)	F-6-2	NUT, HEX., 6MM	E-19-27
GROMMET A, UNDER CASE	F-8-10-3	JOINT ASSY (OUTLET)	F-6-3	NUT, HEX., 6MM	F-8-18
GROMMET, AIR CLEANER CASE	F-8-1	JOINT ASSY., OIL PIPE	E-3-12	NUT, HEX., 6MM	FOP-1-4-25
GROMMET, ELECTRONIC PARTS CASE	E-20-1	JOINT B, WASHER TUBE(MITSUBA)	F-10-8	NUT, HEX., 6MM	FOP-1-6-55
GROMMET, ELECTRONIC PARTS CASE	E-20-10-2	JOINT SET	E-18-6	NUT, HEX., 6MM	FOP-1-6-76
GROMMET, ELECTRONIC PARTS CASE	F-7-10-1	JOINT, DRIVE	F-11-16	NUT, LOCK, 68MM	F-4-19
GROMMET, EXTENSION CASE	F-4-13	JOINT, FUEL PIPE	E-14-8	NUT, PULLEY LOCK	E-19-7
GROMMET, GEAR CASE	F-3-4	JOINT, FUEL PIPE	E-18-38	NUT, SELF-LOCK(25X2.0)	F-10-50
GROMMET, L. IDLE PORT	F-3-20-29	JOINT, FUEL RETURN	E-18-10-12	NUT, SELF-LOCK(3/8-24UNF)	F-10-52
GROMMET, POWER TILT SWITCH	F-3-20-8	JOINT, FUEL TUBE	F-8-20-5	NUT, SELF-LOCK(7/8-14UNF)	F-10-49
GROMMET, R. IDLE PORT	F-3-20-28	JOINT, WATER HOSE	F-3-20-2	NUT, SELF-LOCK 12MM	F-3-21

NUT, SELF-LOCK, 14MM.....	F-3-20-42	PACKING, OIL PAN.....	E-6-2	PLUG, SPARK(ZIFR6K-11E).....	E-20-
NUT, SELF-LOCK, 5MM.....	F-3-19	PACKING, OIL PUMP BODY.....	E-5-2	PLUG, SPARK(ZIFR6K-11E).....	E-20-3
NUT, SELF-LOCK, 6MM.....	F-3-18	PACKING, RELIEF VALVE.....	E-6-10-15	PRIMER BULB.....	F-6-4
NUT, SELF-LOCK, 6MM.....	F-10-47	PACKING, RELIEF VALVE COVER.....	E-6-10-14	PRIMER BULB ASSY.....	F-6-1
NUT, TAPPET ADJUSTING.....	E-9-10-20	PACKING, SINGLE.....	FOP-1-18	PROPELLER COMP., THREE BLADES.....	FOP-12-1
NUT, WATER MOUTH.....	F-3-20-1	PACKING, THROTTLE BODY.....	E-14-10-2	PROPELLER COMP., THREE BLADES.....	FOP-12-
NUT-WASHER, 5MM.....	E-19-26	PACKING, WATER JACKET COVER.....	E-6-10-20	PROPELLER COMP., THREE BLADES.....	FOP-12-
NUT-WASHER, 6MM.....	F-7-10-18	PAN, OIL.....	E-6-1	PROPELLER COMP., THREE BLADES.....	FOP-12-
NUT-WASHER, 8MM.....	F-7-10-17	PANEL ASSY., INDICATOR(4-LED).....	FOP-7-13	PROPELLER COMP., THREE BLADES.....	FOP-12-
<O>		PANEL ASSY., SWITCH.....	FOP-7-3	PROPELLER COMP., THREE BLADES.....	FOP-12-
OIL SEAL.....	F-11-39	PANEL ASSY., SWITCH.....	FOP-7-	PULLER, MINI FUSE.....	F-7-20-4
OIL SEAL, 14X26X6.....	F-2-38	PANEL KIT, SWITCH(4-LED).....	FOP-7-1-1	PULLEY.....	E-19-6
OIL SEAL, 31X46X7(NOK).....	E-5-17	PANEL KIT, SWITCH(4-LED) (EU).....	FOP-7-1-	PULLEY COMP., L. TIMING BELT.....	E-13-5
OIL SEAL, 39.5X52X6(ARAI).....	F-10-69	PANEL KIT, SWITCH(B)(4-LED).....	FOP-7-1	PULLEY COMP., R. TIMING BELT.....	E-13-4
OIL SEAL, 39X53X8(NOK).....	E-9-16	PANEL KIT, SWITCH(B)(4-LED) (EU).....	FOP-7-	PULLEY, CRANKSHAFT.....	E-13-3
OIL SEAL, 41X66X8.....	E-3-42	PANEL, CONTROL.....	FOP-7-4	PULLEY, TIMING BELT DRIVE.....	E-13-1
OIL SEAL, 46X60X9.....	E-5-16	PANEL, CONTROL.....	FOP-7-	PUMP ASSY.....	F-11-14
OIL SEAL, 80X98X10(ARAI).....	E-3-43	PANEL, CONTROL.....	FOP-7-5	PUMP ASSY., FUEL.....	E-1-7
ORIFICE ASSY., OIL CONTROL.....	E-3-10	PANEL, CONTROL.....	FOP-7-1-3	PUMP ASSY., OIL.....	E-5-1
O-RING.....	E-14-10-13	PANEL, CONTROL.....	FOP-7-1-	PUMP KIT, IMPELLER.....	F-4-35
O-RING.....	E-15-25	PIN B, DOWEL, 10X16.....	E-5-20	PUMP KIT, IMPELLER.....	F-4-36
O-RING.....	E-18-13	PIN B, DOWEL, 10X16.....	E-6-20-10	PUMP UNIT SET A, FUEL.....	E-18-7
O-RING.....	E-18-14	PIN, 6X6.....	FOP-1-6-64	PUMP UNIT SET B, FUEL.....	E-18-9
O-RING.....	E-18-15	PIN, LINK.....	F-2-36	PUMP UNIT, FUEL.....	E-18-37
O-RING.....	E-18-16	PIN, LOCK, 6MM.....	FOP-1-6-63	<R>	
O-RING.....	E-18-17	PIN, PISTON.....	E-7-3	RECEIVER, THRUST.....	F-10-30
O-RING.....	E-18-18	PIN, SHIFTER, 8X50.....	F-5-2	RECTIFIER ASSY.....	E-19-19
O-RING.....	E-18-19	PIN, SNAP, 6MM.....	F-2-35	REGULATOR ASSY.....	E-19-20
O-RING.....	E-18-1-20	PIN, SPLIT, 4.0.....	F-5-22	REGULATOR ASSY., PRESSURE.....	E-14-6
O-RING.....	E-18-1-21	PIN, SPLIT, 4.0.....	FOP-14-2	RELAY ASSY., FUEL PUMP(DENSO).....	F-7-20-5
O-RING.....	E-18-1-23	PIN, SPRING, 3X20.....	F-10-73	RELAY ASSY., POWER TILT.....	F-7-10-9
O-RING.....	F-4-29	PIN, UPPER CYLINDER.....	F-11-28	RELAY ASSY., POWER(12V-20A).....	F-7-20-6
O-RING.....	FOP-14-7	PIN, VERTICAL SHAFT.....	E-13-19	RETAINER, SPRING.....	E-7-13
O-RING SET, 3.5X31.7.....	F-11-47	PIPE COMP., L. EX.....	E-6-5	RETAINER, VALVE SPRING.....	E-9-10-15
O-RING, 1.8X69.6.....	F-11-41	PIPE COMP., L. FUEL.....	E-14-5	RING.....	E-18-32
O-RING, 1.8X7.7.....	F-11-43	PIPE COMP., R. EX.....	E-6-3	RING SET, PISTON(STD.)(RIKEN).....	E-7-1
O-RING, 1.9X11.....	F-11-44	PIPE, FUEL.....	E-18-10-7	RING, BACK UP.....	F-11-20
O-RING, 121X3.1.....	F-5-30	PIPE, HARNESS GUIDE.....	FOP-1-6-32	RING, CROSS PIN.....	F-5-3
O-RING, 121X3.1.....	FOP-14-8	PIPE, R. FUEL.....	E-14-3	RING, INNER(15X20X23).....	F-2-37
O-RING, 13X1.5(ARAI).....	E-3-48	PISTON.....	E-7-2	RING, SETTING(39).....	F-5-21
O-RING, 15.54X2.26.....	F-10-70	PISTON COMP., FREE.....	F-11-24	RING, STOPPER.....	F-2-7
O-RING, 16.3X3.5.....	E-3-47	PIVOT, SHIFT.....	F-2-12	RING, WATER TUBE SEAL.....	F-4-8
O-RING, 16MM.....	E-6-10-36	PIVOT, SHIFT.....	FOP-1-6-17	ROD COMP. A, SHIFT(XL).....	F-4-11
O-RING, 18.3X3.5.....	E-3-45	PLATE.....	E-18-10	ROD COMP., CONNECTING.....	E-7-7
O-RING, 2.0X70.5.....	F-11-40	PLATE.....	E-18-45	ROD COMP., PISTON.....	F-11-22
O-RING, 20.6X2.6.....	E-5-18	PLATE.....	E-18-1-22	ROD COMP., PISTON(B).....	F-11-15
O-RING, 23.5X2.....	E-6-10-39	PLATE COMP., SLIDING.....	FOP-1-6-15	ROD COMP., SHIFT.....	F-4-9
O-RING, 25X2.4(NOK).....	E-3-49	PLATE SET, TRANSOM(5.5MM FLAT).....	FOP-9-2	ROD KIT, STEERING.....	F-10-3
O-RING, 26.2X2.4(NOK).....	E-3-46	PLATE SET, TRIM ADJUST.....	FOP-9-1	ROD, LINK.....	F-2-10
O-RING, 26.9X2.4(NOK).....	F-2-40	PLATE, CABLE CLAMP.....	FOP-1-11	ROLLER, 3X13.8.....	F-5-28
O-RING, 26X2.7.....	E-3-10-17	PLATE, CABLE CLAMP.....	FOP-1-2-12	ROLLER, 5X8.....	E-5-24
O-RING, 3.5X35.7.....	F-11-45	PLATE, DWELL.....	FOP-1-15	ROLLER, CLICK.....	FOP-1-6-65
O-RING, 3.5X38.7.....	F-11-42	PLATE, DWELL.....	FOP-1-2-16	ROTOR ASSY.....	E-19-15
O-RING, 3.5X41.7.....	F-11-46	PLATE, DWELL.....	FOP-1-4-10	ROTOR COMP.....	E-21-2
O-RING, 31.5X2.4(ARAI).....	E-4-25	PLATE, HANDLE.....	FOP-1-10	ROTOR, OIL PUMP INNER.....	E-5-5
O-RING, 33.5X2.....	E-6-10-38	PLATE, HANDLE.....	FOP-1-2-11	ROTOR, OIL PUMP OUTER.....	E-5-6
O-RING, 37X2.4(ARAI).....	E-1-25	PLATE, INTAKE MANIFOLD CENTER.....	E-14-10-4	RPACKING.....	E-21-17
O-RING, 48.5X2.4.....	E-9-17	PLATE, L. TIMING BELT COVER.....	E-13-10-4	RUBBER C, STAND STOPPER.....	F-3-20-55
O-RING, 49.4X3.1.....	E-6-10-37	PLATE, LEVER SETTING.....	FOP-1-6-8	RUBBER, DRAIN PLUG.....	F-3-20-11
O-RING, 59.4X3.1.....	E-21-23	PLATE, LOCK.....	F-2-13	RUBBER, FR. CARRIER CUSHION.....	F-8-10-11
O-RING, 6.9X1.45.....	F-3-25	PLATE, R. TIMING BELT COVER.....	E-13-10-5	RUBBER, MOUNT CASE SEAL.....	E-6-10-23
O-RING, 6.9X1.45.....	FOP-14-6	PLATE, REMOTE CONTROL.....	FOP-1-6-47	RUBBER, OIL PUMP.....	E-5-3
O-RING, 65.4X2.4.....	F-4-32	PLATE, REMOTE CONTROL CABLE.....	F-2-2	RUBBER, RING.....	E-4-11
O-RING, 66.4X3.1.....	E-4-23	PLATE, REMOTE CONTROL(EU).....	FOP-1-6-	RUBBER, STOPPER.....	F-8-10-10
O-RING, 7.45X3.61(NOK).....	E-14-29	PLATE, REMOTE CONTROL(REVERSE).....	FOP-1-6-48	RUBBER, UPPER MOUNT STOPPER.....	F-10-16
O-RING, 7.47X3.6.....	E-14-28	PLATE, RUBBER SETTING.....	F-3-1	<S>	
O-RING, 7.8X1.9(ARAI).....	E-14-27	PLATE, SHIFT.....	F-5-7	SCREEN COMP., FUEL STRAINER.....	E-18-39
O-RING, 7.8X1.9(ARAI).....	E-18-55	PLATE, SPRING SETTING.....	FOP-1-6-23	SCREEN, L. WATER.....	F-3-7
O-RING, 8.8X2.4.....	E-3-11	PLATE, STARTER CABLE.....	F-8-10-2	SCREEN, R. WATER.....	F-3-6
O-RING, 9.5X1.9.....	E-3-44	PLATE, TIMING BELT GUIDE.....	E-13-2	SCREW.....	E-19-9
O-RING, 9.5X1.9.....	E-4-24	PLATE, WATER TUBE.....	E-6-7	SCREW.....	E-19-10
O-RING, PRESSURE REGULATOR.....	E-14-7	PLATE, WINKER BUZZER.....	FOP-1-6-45	SCREW SET.....	E-15-1
O-RING, TIMING BELT TENSIONER.....	E-13-11	PLATE, WINKER BUZZER.....	FOP-7-15	SCREW SET, DRAIN.....	E-18-5
O-RING, WATER PUMP.....	F-4-30	PLATE, WINKER BUZZER.....	FOP-7-1-12	SCREW SET, DRAIN.....	E-18-1-34
O-RING, WATER PUMP HOUSING.....	F-4-31	PLUG, BLIND, 20MM.....	F-8-19	SCREW, 6X95.....	FOP-1-6-53
<P>		PLUG, FUEL TUBE.....	F-8-20-2	SCREW, FLAT, 5X12.....	FOP-1-6-52
PACKING.....	F-11-49	PLUG, HOLE, 5MM.....	F-3-20-54	SCREW, FLAT, 5X55.....	F-3-11
PACKING, DUAL.....	FOP-1-2-19	PLUG, INNER CONNECTOR.....	FOP-1-6-35	SCREW, FLAT, 6X16.....	E-5-19
PACKING, FLASH VALVE.....	E-6-10-16	PLUG, INNER CONNECTOR.....	FOP-7-7	SCREW, PAN.....	E-18-21
PACKING, HEAD COVER.....	E-1-2	PLUG, INNER CONNECTOR.....	FOP-7-1-5	SCREW, PAN, 4X10.....	FOP-1-26
PACKING, INTAKE MANIFOLD UP.....	E-14-10-6	PLUG, OUTER CONNECTOR.....	FOP-1-6-36	SCREW, PAN, 4X10.....	FOP-1-2-29
PACKING, OIL HOLE.....	E-3-9	PLUG, OUTER CONNECTOR.....	FOP-7-8	SCREW, PAN, 5X10.....	FOP-1-23
PACKING, OIL LEVEL GAUGE.....	E-3-17	PLUG, OUTER CONNECTOR.....	FOP-7-1-6		



SCREW, PAN, 5X10.....	FOP-1-2-26	SENSOR COMP., KNOCK.....	E-3-20	STAY, A.C. GENERATOR.....	E-19-16
SCREW, PAN, 5X10.....	FOP-1-6-70	SENSOR COMP., TDC1-TDC2.....	E-13-10-6	STAY, FUEL PIPE A.....	E-18-1-2
SCREW, PAN, 5X12.....	E-18-1-14	SENSOR, OXYGEN.....	E-4-14	STAY, FUEL PIPE B.....	E-18-1-3
SCREW, PAN, 5X16.....	E-3-51	SEPARATOR ASSY., VAPOR.....	E-18-33	STAY, FUEL STRAINER.....	E-18-1-17
SCREW, PAN, 5X16.....	FOP-1-22	SEPARATOR ASSY., WATER.....	E-18-1-4	STAY, PLATE.....	E-18-8
SCREW, PAN, 5X16.....	FOP-1-2-25	SHAFT ASSY., CLUTCH.....	E-21-13	STAY, PLATE.....	E-18-36
SCREW, PAN, 5X16.....	FOP-1-4-20	SHAFT ASSY., CLUTCH.....	E-21-	STAY, POWER TILT SWITCH.....	F-3-20-6
SCREW, PAN, 5X18.....	FOP-1-25	SHAFT ASSY., GEAR.....	E-21-15	STAY, VACUUM TANK.....	E-18-44
SCREW, PAN, 5X18.....	FOP-1-2-28	SHAFT ASSY., GEAR.....	E-21-	STAY, WATER SEPARATOR.....	E-18-1-7
SCREW, PAN, 5X20.....	E-3-52	SHAFT COMP., EX. ROCKER ARM.....	E-9-10-8	STOPPER SET, SLEEVE.....	E-21-8
SCREW, PAN, 5X20.....	FOP-1-24	SHAFT COMP., INTAKE ROCKER ARM.....	E-9-10-7	STOPPER SET, SLEEVE.....	E-21-
SCREW, PAN, 5X20.....	FOP-1-2-27	SHAFT COMP., SHIFT(A).....	F-2-8	STOPPER, LOWER MOUNT.....	F-3-20-18
SCREW, PAN, 5X30.....	FOP-1-4-22	SHAFT COMP., SHIFT(B).....	F-2-14	STOPPER, TILT.....	F-10-29
SCREW, PAN, 5X40.....	FOP-1-28	SHAFT, COVER OPEN.....	F-8-10-19	STRAINER ASSY., FUEL.....	E-18-1-11
SCREW, PAN, 5X40.....	FOP-1-2-31	SHAFT, FR. LOCK.....	F-8-10-20	STRAINER COMP., OIL.....	E-5-7
SCREW, PAN, 5X40.....	FOP-6-3	SHAFT, PROPELLER.....	F-5-10	STRAINER, FUEL PUMP.....	E-18-10-8
SCREW, PAN, 5X40.....	FOP-7-18	SHAFT, THROTTLE BUTTON.....	FOP-1-4-9	SUB HARNESS ASSY., POWER.....	FOP-1-19
SCREW, PAN, 5X40.....	FOP-7-1-15	SHAFT, TILTING.....	F-10-26	SUB HARNESS ASSY., POWER.....	FOP-1-2-20
SCREW, PAN, 5X55.....	FOP-1-2-32	SHAFT, VERTICAL(XL).....	F-4-14	SUB HARNESS ASSY., POWER.....	FOP-1-2-21
SCREW, PAN, 5X65.....	FOP-1-34	SHIFTER, CLUTCH.....	F-5-1	SUB HARNESS ASSY., POWER.....	FOP-1-4-16
SCREW, PAN, 5X65.....	FOP-1-2-39	SHIM A, BEVEL(0.10).....	F-5-18	SUSPENSION, COUPLER.....	F-7-2
SCREW, PAN, 5X8.....	E-21-22	SHIM A, GEAR(0.10).....	F-4-22	SUSPENSION, STRAINER.....	E-18-1-18
SCREW, PAN, 6X10.....	FOP-1-6-51	SHIM A, THRUST(2.75).....	F-5-19	SUSPENSION, STRAINER.....	E-18-1-19
SCREW, PAN, 6X18.....	E-4-26	SHIM B, BEVEL(0.15).....	F-5-	SUSPENSION, STRAINER.....	E-18-10-9
SCREW, PAN, 6X18.....	FOP-1-27	SHIM B, GEAR(0.15).....	F-4-	SWITCH ASSY., COMBINATION.....	FOP-1-6-38
SCREW, PAN, 6X18.....	FOP-1-2-30	SHIM B, THRUST(2.80).....	F-5-	SWITCH ASSY., COMBINATION.....	FOP-7-9
SCREW, PAN, 6X22.....	E-21-	SHIM C, BEVEL(0.30).....	F-5-	SWITCH ASSY., COMBINATION.....	FOP-7-1-7
SCREW, PAN, 6X22(SPECIAL).....	E-21-21	SHIM C, GEAR(0.30).....	F-4-	SWITCH ASSY., EMERGENCY STOP.....	FOP-1-6-41
SCREW, PAN, 6X25.....	F-3-20-40	SHIM C, THRUST(2.85).....	F-5-	SWITCH ASSY., EMERGENCY STOP.....	FOP-7-10
SCREW, PAN, 6X35.....	FOP-1-4-23	SHIM D, BEVEL(0.50).....	F-5-	SWITCH ASSY., EMERGENCY STOP.....	FOP-7-1-8
SCREW, PAN, 6X8.....	F-10-44	SHIM D, GEAR(0.50).....	F-4-	SWITCH ASSY., MAGNET.....	E-21-12
SCREW, PAN, 6X8.....	F-10-77	SHIM D, THRUST(2.90).....	F-5-	SWITCH ASSY., MAGNET.....	E-21-
SCREW, PAN, 6X8.....	F-11-35	SHIM E, THRUST(2.95).....	F-5-	SWITCH ASSY., NEUTRAL.....	F-2-18
SCREW, RIVET, 5X10.....	F-10-45	SHIM F, THRUST(3.00).....	F-5-	SWITCH ASSY., OIL PRESSURE.....	E-3-24
SCREW, RIVET, 5X10.....	F-11-36	SHIM G, THRUST(3.05).....	F-5-	SWITCH ASSY., OIL PRESSURE.....	E-3-25
SCREW, SPECIAL, 6X35.....	F-3-20-34	SHIM H, THRUST(3.10).....	F-5-	SWITCH ASSY., POWER TILT.....	F-3-20-5
SCREW, TAPPET ADJUSTING.....	E-9-10-12	SHIM I, THRUST(2.70).....	F-5-	SWITCH ASSY., POWER TRIM-TILT.....	FOP-1-20
SCREW, TAPPING.....	FOP-8-3	SHIM J, THRUST(2.65).....	F-5-	SWITCH ASSY., POWER TRIM-TILT.....	FOP-1-2-22
SCREW, TAPPING, 4X10.....	F-8-17	SHIM K, THRUST(2.60).....	F-5-	SWITCH ASSY., POWER TRIM-TILT.....	FOP-1-2-23
SCREW, TAPPING, 5X10.....	FOP-1-6-72	SHIM L, THRUST(2.55).....	F-5-	SWITCH ASSY., POWER TRIM-TILT.....	FOP-1-4-17
SCREW, TAPPING, 5X12.....	FOP-1-6-73	SHIM M, THRUST(2.50).....	F-5-	SWITCH ASSY., POWER TRIM-TILT.....	FOP-1-6-39
SCREW, TAPPING, 5X25.....	FOP-1-6-75	SLIDER COMP., SHIFT.....	F-5-4	SWITCH KIT, LIGHT.....	FOP-6-1
SCREW, TAPPING, 5X8.....	FOP-1-6-71	SLIDER, SHIFT.....	F-5-5	<T>	
SCREW, TAPPING, 6X16.....	FOP-1-6-74	SLINGER, OIL.....	F-4-15	TAB, TRIM.....	F-3-8
SCREW, TAPPING, 6X30.....	FOP-1-4-24	SPACER KIT, REMOTE CONTROL BOX.....	FOP-1-2	TACHOMETER HOUR METER (BLACK).....	FOP-3-4
SCREW, TRUSS, 4X12.....	FOP-1-4-21	SPACER KIT, REMOTE CONTROL BOX.....	FOP-1-2-2	TANK COMP., VACUUM.....	E-18-43
SCREW, WASHER.....	E-18-22	SPACER, CABLE CLAMP.....	FOP-1-17	TANK, OIL.....	F-11-29
SCREW, WAVE WASHER.....	E-19-12	SPACER, CABLE CLAMP.....	FOP-1-2-18	TENSIONER COMP., TIMING BELT.....	E-13-7
SCREW, WAVE WASHER.....	E-19-13	SPACER, CABLE CLAMP.....	FOP-1-4-13	TERMINAL, CABLE.....	FOP-1-16
SCREW-WASHER.....	E-18-20	SPACER, CABLE CLAMP.....	FOP-1-6-33	TERMINAL, CABLE.....	FOP-1-2-17
SCREW-WASHER.....	E-19-11	SPACER, CLICK SPRING.....	FOP-1-6-27	TERMINAL, CABLE.....	FOP-1-4-12
SCREW-WASHER, 5X15.....	F-7-20-8	SPACER, INTAKE MANIFOLD.....	E-14-16	THERMOSTAT ASSY.....	E-4-10
SEAL A, COVER UNDER.....	F-3-20-22	SPACER, L. RELIEF VALVE.....	E-6-10-18	THROTTLE BODY ASSY.....	E-15-3
SEAL A, VALVE STEM(NOK).....	E-9-4	SPACER, NEUTRAL SWITCH.....	FOP-1-6-30	TIE, CABLE.....	FOP-10-2
SEAL B, COVER UNDER.....	F-3-20-23	SPACER, R. RELIEF VALVE.....	E-6-10-12	TIE, CABLE(NATURAL)(2.4X92).....	FOP-1-6-37
SEAL B, EX. GUIDE.....	E-6-10-4	SPACER, REMOTE CONTROL BOX.....	FOP-1-6-26	TIE, CABLE(NATURAL)(2.4X92).....	FOP-13-4
SEAL B, VALVE STEM(NOK).....	E-9-6	SPACER, THERMOSTAT COVER.....	E-4-12	T-JOINT.....	E-1-10
SEAL C, UNDER COVER.....	F-3-20-25	SPACER, THROTTLE BODY.....	E-15-4	T-JOINT.....	E-18-10-17
SEAL D, UNDER COVER.....	F-8-10-25	SPRING COMP., CLICK.....	F-2-5	TRIM METER ASSY (BLACK).....	FOP-3-1
SEAL, ENGINE COVER.....	F-8-3	SPRING COMP., CLICK.....	F-10-4	TRIM-TILT ASSY., POWER.....	F-11-13
SEAL, EXHAUST GUIDE.....	E-6-10-3	SPRING COMP., TIMING BELT.....	E-13-9	TUBE A, AIR VENT.....	E-18-10-4
SEAL, L. IDOL PORT.....	F-3-20-15	SPRING, ACCELERATOR WHEEL.....	FOP-1-6-21	TUBE B, AIR VENT.....	E-18-10-5
SEAL, R. IDOL PORT.....	F-3-20-14	SPRING, AIR FLOW TUBE.....	E-15-7	TUBE B, BREATHER.....	E-1-27
SEAL, SPARK PLUG TUBE(NOK).....	E-1-4	SPRING, CHOKE RETURN.....	FOP-1-6-25	TUBE C, BREATHER.....	E-1-28
SEAL, UPPER MOUNT COVER.....	F-10-19	SPRING, CLICK ASSIST.....	F-2-6	TUBE COMP. A, BREATHER.....	E-1-26
SEAL, WATER.....	F-11-48	SPRING, CLICK ASSIST.....	F-10-5	TUBE COMP. A, FUEL.....	F-8-20-1
SEAL, WATER(14X26X8).....	F-2-39	SPRING, COVER LOCK HOOK.....	F-8-10-17	TUBE COMP. B, FUEL.....	E-18-1-8
SEAL, WATER, 12X21X6.....	F-4-28	SPRING, EX. VALVE.....	E-9-10-14	TUBE COMP. C, FUEL.....	E-1-8
SEAL, WATER, 12X21X6.....	FOP-14-5	SPRING, FLUSH VALVE.....	E-6-10-8	TUBE COMP. D, FUEL.....	E-18-1-9
SEAL, WATER, 22X35X7.....	E-6-10-35	SPRING, LOCK ADJUSTER.....	F-8-7	TUBE COMP. E, FUEL.....	E-18-1-10
SEAL, WATER, 26X42X7.....	F-4-27	SPRING, LOCK LEVER RETURN.....	F-8-10-18	TUBE COMP. G, FUEL.....	E-1-9
SEAL, WATER, 26X42X7.....	FOP-14-3	SPRING, MOTOR.....	F-11-9	TUBE COMP., AIR VENT.....	E-18-10-6
SEAL, WATER, 30X45X7.....	F-5-29	SPRING, NEUTRAL LOCK ARM.....	FOP-1-4-7	TUBE KIT, SPEED SENSOR.....	F-10-2
SEAL, WATER, 30X45X7.....	FOP-14-4	SPRING, RELIEF VALVE.....	E-5-9	TUBE, 5X200.....	F-10-74
SEAT, SPRIND(250).....	E-7-14	SPRING, RELIEF VALVE.....	E-6-10-11	TUBE, 5X950.....	F-10-75
SEAT, VALVE SPRING.....	E-9-10-16	SPRING, REMOTE CONTROL HANDLE.....	FOP-1-6-7	TUBE, CHECK VALVE.....	E-18-10-3
SEAT, WATER MOUTH.....	F-3-20-3	SPRING, ROCKER ARM.....	E-9-10-9	TUBE, FLUSH VALVE.....	E-6-10-41
SENSOR ASSY., AIR TEMP.....	E-15-16	SPRING, SET.....	E-18-40	TUBE, FUEL, 3.5X130.....	E-14-10-21
SENSOR ASSY., CRANK.....	E-3-27	SPRING, SHIFT.....	F-5-6	TUBE, FUEL, 3.5X40.....	E-14-10-20
SENSOR ASSY., MAP.....	E-14-10-12	SPRING, SHIFT CLICK.....	FOP-1-6-24	TUBE, FUEL, 3.5X50.....	E-14-31
SENSOR ASSY., TRIM ANGLE.....	F-10-7	SPRING, SHIFT ROD.....	F-4-10	TUBE, FUEL, 3.5X540.....	E-14-10-22
SENSOR ASSY., WATER.....	E-3-26	SPRING, VALVE(PINK).....	E-9-10-13	TUBE, FUEL, 3.5X55.....	E-18-10-24
SENSOR ASSY., WATER.....	E-4-15	SPRING,SUPPORT.....	E-7-15	TUBE, FUEL, 3.5X590.....	E-14-10-23



TUBE, FUEL, 3.5X600 .....	E-14-10-24	WASHER, PLAIN, 8MM .....	F-8-10-28
TUBE, L. WATER RETURN .....	E-4-9	WASHER, PLAIN, 8MM .....	F-8-10-35
TUBE, OIL .....	E-1-5	WASHER, PLAIN, 8MM .....	FOP-1-6-61
TUBE, R. WATER RETURN .....	E-4-6	WASHER, PROPELLER .....	F-5-17
TUBE, SPIRAL(12X14.6) .....	F-11-4	WASHER, PROPELLER THRUST .....	F-5-15
TUBE, VINYL, 3.5X6.5X350 .....	E-18-1-33	WASHER, SEALING(22MM) .....	E-3-8
TUBE, VINYL, 3.5X6.5X600 .....	E-18-10-25	WASHER, SEALING(22MM) .....	E-3-10-3
TUBE, WATER .....	E-4-8	WASHER, SEALING, 22MM .....	E-3-7
TUBE, WATER CHECK .....	E-6-10-40	WASHER, SEALING, 6MM .....	E-18-53
TUBE, WATER IN .....	E-18-10-15	WASHER, SPRING, 5MM .....	FOP-6-5
TUBE, WATER JOINT .....	F-3-20-51	WASHER, SPRING, 5MM .....	FOP-7-22
TUBE, WATER OUTLET .....	E-18-10-16	WASHER, SPRING, 5MM .....	FOP-7-1-19
TUBE, WATER RELIEF .....	E-4-7	WASHER, THRUST .....	E-7-11
TUBE, WATER(XL) .....	F-4-7	WASHER, THRUST .....	E-7-
<V>		WASHER, THRUST BEARING .....	F-5-16
VALVE ASSY., AIR BYPASS .....	E-14-10-10	WASHER, THRUST, 14MM .....	F-2-29
VALVE ASSY., EAC .....	E-15-17	WASHER, THRUST, 34MM .....	F-10-56
VALVE ASSY., SPOOL .....	E-3-18	WASHER, UPPER MOUNTING STOPPER ..	F-10-57
VALVE COMP., MANUAL .....	F-11-25	WASHER, WAVE, 10MM .....	F-8-10-34
VALVE COMP., RESERVOIR .....	F-11-26	WASHER, WAVE, 12MM .....	F-10-54
VALVE SET, FLOAT .....	E-18-1	WASHER, WAVE, 26MM .....	F-10-55
VALVE, CHECK .....	E-14-10-9	WASHER, WAVE, 40MM .....	F-10-53
VALVE, CHECK .....	E-18-10-18	WASHER, WAVE, 8MM .....	F-8-10-33
VALVE, EX .....	E-9-10-11	WHEEL, ACCELERATOR .....	FOP-1-6-20
VALVE, FLASH .....	E-6-10-10	WHEEL, CONTROL .....	FOP-1-6-13
VALVE, IN .....	E-9-10-10	WIRE, LEAD(1.5X116MM) .....	F-10-9
VALVE, RELIEF .....	E-5-8	WIRE, LEAD(1.5X116MM) .....	F-11-11
VALVE, RELIEF .....	E-6-10-9	WRENCH, BOX(10MM) .....	F-13-14
<W>		WRENCH, EYE, 19MM .....	F-13-12
WASHER .....	F-2-32	WRENCH, HEX, 6MM .....	F-13-7
WASHER B, THRUST, 14MM .....	F-2-30	WRENCH, PLUG .....	F-13-6
WASHER KIT, THRUST(250) .....	E-7-16	<Y>	
WASHER, 10MM .....	F-10-62	YOKE ASSY .....	F-11-8
WASHER, 25MM .....	F-10-59	YOKE COMP. ....	E-21-5
WASHER, 28MM .....	FOP-1-6-62		
WASHER, 30MM .....	F-3-20-43		
WASHER, 6MM .....	FOP-1-6-60		
WASHER, 7/8INCH .....	F-10-58		
WASHER, AIR CLEANER COVER .....	F-2-1		
WASHER, CONICAL SPRING(5) .....	E-14-10-11		
WASHER, DRAIN PLUG, 12MM .....	E-6-13		
WASHER, LOCK, 5MM .....	FOP-1-30		
WASHER, LOCK, 5MM .....	FOP-1-2-35		
WASHER, LOCK, 5MM .....	FOP-1-4-26		
WASHER, LOCK, 6MM .....	FOP-1-32		
WASHER, LOCK, 6MM .....	FOP-1-2-37		
WASHER, PIVOT .....	F-2-4		
WASHER, PLAIN .....	E-18-24		
WASHER, PLAIN .....	E-18-25		
WASHER, PLAIN, 10MM .....	E-6-20-8		
WASHER, PLAIN, 10MM .....	F-3-20-46		
WASHER, PLAIN, 10MM .....	F-8-10-32		
WASHER, PLAIN, 10MM .....	F-10-60		
WASHER, PLAIN, 12MM .....	E-6-20-7		
WASHER, PLAIN, 12MM .....	F-3-22		
WASHER, PLAIN, 12MM .....	F-3-20-45		
WASHER, PLAIN, 12MM .....	F-4-21		
WASHER, PLAIN, 12MM .....	F-5-20		
WASHER, PLAIN, 12MM .....	F-8-15		
WASHER, PLAIN, 12MM .....	F-10-63		
WASHER, PLAIN, 12MM .....	F-10-64		
WASHER, PLAIN, 14MM .....	F-3-20-44		
WASHER, PLAIN, 4MM .....	FOP-1-6-56		
WASHER, PLAIN, 5MM .....	FOP-1-31		
WASHER, PLAIN, 5MM .....	FOP-1-33		
WASHER, PLAIN, 5MM .....	FOP-1-2-36		
WASHER, PLAIN, 5MM .....	FOP-1-2-38		
WASHER, PLAIN, 5MM .....	FOP-1-6-57		
WASHER, PLAIN, 5MM .....	FOP-1-6-58		
WASHER, PLAIN, 5MM .....	FOP-6-4		
WASHER, PLAIN, 5MM .....	FOP-7-21		
WASHER, PLAIN, 5MM .....	FOP-7-1-18		
WASHER, PLAIN, 6MM .....	E-15-24		
WASHER, PLAIN, 6MM .....	F-2-31		
WASHER, PLAIN, 6MM .....	F-2-33		
WASHER, PLAIN, 6MM .....	F-2-34		
WASHER, PLAIN, 6MM .....	F-8-14		
WASHER, PLAIN, 6MM .....	F-10-61		
WASHER, PLAIN, 6MM .....	FOP-1-4-27		
WASHER, PLAIN, 6MM .....	FOP-1-6-59		
WASHER, PLAIN, 8MM .....	E-1-20		
WASHER, PLAIN, 8MM .....	E-6-12		
WASHER, PLAIN, 8MM .....	F-7-10-19		

# INDEX (Parts Number)

332-70201-0	F-6-8	HCO-94302-10160	E-5-20	HP0X-91321-003	E-3-49	HPZ1-12211-004	E-9-6
3C7-70211-1	F-6-4	HCO-94302-10160	E-6-20-10	HP13-31141-003	E-19-6	HR70-15280-A00	E-3-13
3C7-70217-0	F-6-5	HCO-94303-05080	E-3-54	HP13-31147-003	E-19-10	HRCA-14632-A00	E-9-10-8
3C7-70220-1	F-6-2	HCO-94305-30203	F-10-73	HP13-31148-003	E-19-12	HRCA-17055-A01	E-14-12
3C7-70224-1	F-6-3	HCO-94510-15000	F-5-31	HP5A-13115-000	E-7-4	HRCA-17065-A01	E-14-14
3PU-72537-0	FOP-3-6	HCO-94520-47000	F-4-37	HP5A-31201-005	E-21-2	HRCA-90014-A01	E-3-32
3PV-72571-0	FOP-3-1	HCO-94540-03029	FOP-1-6-78	HP5A-31243-005	E-21-14	HRCA-90704-A00	E-13-28
3PV-72637-0	FOP-3-4	HCO-94540-04029	F-2-42	HP5G-16614-003	E-14-4	HRDV-14765-J00	E-9-10-15
3T1-70200-1	F-6-1	HCO-94540-04029	FOP-1-6-79	HP8A-11812-A00	E-13-10-1	HRRG-14781-A01	E-9-10-17
98AB-701600	F-6-7	HCO-94540-06029	F-8-10-39	HP8A-13204-A01	E-7-6	HRJA-14711-000	E-9-10-10
98AB-70-700	F-6-6	HCO-94540-06029	FOP-1-36	HP8A-14400-A01	E-13-6	HRJA-14721-E00	E-9-10-11
H121-51640-730	F-8-10-11	HCO-94540-06029	FOP-1-2-41	HP8A-14551-A01	E-13-13	HRJA-15290-000	E-3-14
H196-47117-000	F-8-10-10	HCO-94540-06029	FOP-1-4-28	HP8A-14620-A01	E-9-10-4	HRJA-90017-003	E-13-22
H341-38403-672	FOP-1-6-45	HCO-94540-07029	FOP-1-6-80	HP8A-14626-A00	E-9-10-5	HRRG-13210-000	E-7-7
H341-38403-672	FOP-7-15	HCO-94540-10019	F-4-34	HP8A-14627-A00	E-9-10-6	HRRG-13310-000	E-7-9
H341-38403-672	FOP-7-1-12	HCO-94540-12029	F-2-43	HP8A-14631-A00	E-9-10-7	HRRG-14761-003	E-9-10-13
H355-89217-000	F-13-14	HCO-94540-15029	F-11-51	HP8A-14645-A01	E-9-10-9	HRRG-91213-003	E-9-16
H371-89221-000	F-13-7	HCO-95001-35040-40	E-14-10-20	HP8A-15115-A01	E-3-9	HRNA-30530-A01	E-3-20
H371-90009-015	E-6-20-2	HCO-95001-35050-40	E-14-31	HP8A-15140-A00	E-3-10	HRNA-37830-A01	E-14-10-12
H663-38562-920	F-10-8	HCO-95001-35055-40	E-18-10-24	HP8A-15142-A00	E-3-11	HRTA-15400-004	E-3-10-4
H723-90472-000	F-4-21	HCO-95001-35130-40	E-14-10-21	HP8A-15150-A00	E-3-12	HRYE-13211-A01	E-7-8
H759-16911-003	E-18-10-8	HCO-95001-35540-40	E-14-10-22	HP8A-90003-A00	E-9-10-18	HRYE-13212-A01	E-7
H763-90681-A01	F-7-10-21	HCO-95001-35590-60	E-14-10-23	HP8A-90004-A00	E-9-10-19	HRYE-13213-A01	E-7
H763-90681-A01	F-10-67	HCO-95001-35600-40	E-14-10-24	HP8A-90017-A01	E-13-10-8	HRYE-13214-A01	E-7
H800-91303-000	E-6-10-36	HCO-95003-05035-31	E-18-1-33	HP8A-90031-A01	E-13-25	HRYE-13215-A01	E-7
H805-91301-000	E-3-10-15	HCO-95003-05060-31	E-18-10-25	HP8A-90701-A00	E-9-14	H50A-91541-003	E-3-50
H881-90110-000	F-10-42	HCO-95005-50200-30	F-10-74	HP8A-91301-A00	E-9-17	H50A-91541-003	E-13-10-11
H921-15611-000	E-3-10-5	HCO-95005-50950-30	F-10-75	HP8A-91308-A01	E-3-45	H50A-91541-003	F-2-41
H921-17936-000	F-2-4	HCO-95011-63000	F-3-20-55	HP8A-91309-A01	E-3-47	H50A-91541-003	F-7-5
H921-90302-000	F-3-20-41	HCO-95551-20000	F-8-19	HP8D-36165-J00	E-14-10-11	H50A-91541-003	F-7-10-24
H921-90302-000	FOP-1-6-54	HCO-95701-06014-09	E-5-21	HP8E-14762-A01	E-9-10-14	H50A-91541-003	F-8-10-37
H921-90302-000	FOP-7-19	HCO-95701-06018-09	E-5-22	HP8E-17105-A01	E-14-15	H50X-46392-A01	F-2-21
H921-90302-000	FOP-7-1-16	HCO-95701-08030-09	E-5-23	HP8F-14820-A01	E-9-10	H5A0-90683-003	E-18-1-31
H921-90504-010	F-8-14	HCO-95701-10070-09	E-6-20-11	HPC6-15233-000	E-5-10	H5A0-90683-003	E-20-10-10
H921-90504-010	FOP-1-6-59	HCO-95701-12120-09	E-6-20-12	HPC6-91324-000	E-5-18	H5A0-90683-003	F-3-20-49
H921-90511-000	F-10-60	HCO-96211-07000	F-5-32	HPD1-31138-004	E-19-5	H5B0-90602-003	F-11-37
H921-90512-010	FOP-1-6-60	HCO-96211-12000	F-5-33	HPD1-31142-004	E-19-7	H5B2-90620-003	F-7-10-20
H921-90518-000	F-8-10-35	HCO-96220-550080	E-5-24	HPD1-31145-004	E-19-8	H5B2-90650-003	E-14-26
H921-90518-000	FOP-1-6-61	HCO-9807B-5617C	E-20-	HPD1-90231-014	E-19-26	H5B6-91475-000	FOP-1-6-66
H921-90602-000	E-18-1-27	HCO-98200-41000	F-7-20-9	HPD6-90430-003	E-18-53	H5C2-90649-003	FOP-7-20
H921-90602-000	F-10-65	HCO-98200-41500	F-7-20-10	HPE0-15231-000	E-5-8	H5C2-90649-003	FOP-7-1-17
H952-32901-770	FOP-1-6-37	HCO-98200-43000	F-7-20-11	HPEA-13111-000	E-7-3	H5D2-90705-931	F-2-35
H952-32901-770	FOP-13-4	HCO-99003-30000	F-13-15	HPF0-91302-003	F-2-40	H5D4-91356-952	E-4-25
H958-90428-000	F-2-30	HCO-99003-50000	F-13-16	HPG6-15232-000	E-5-9	H5D9-54316-013	E-1-15
HCO-92101-05016-4J	FOP-1-6-69	HCO-99006-19000	F-13-12	HPG7-16741-005	E-14-7	H5DA-39794-004	F-7-20-5
HCO-92101-06055-4J	F-3-26	HCO-99008-02000	F-13-13	HPGK-37835-A01	E-14-10-13	H5E0-53740-953	E-1-14
HCO-93500-05010-4J	FOP-1-6-70	HGCF-80106-670	F-8-20-3	HPH1-90015-013	E-3-10-7	H5F4-89216-000	F-13-6
HCO-93500-05016-4J	E-3-51	HGHB-16163-600	E-18-1-1	HPH7-90715-000	E-3-41	H5J6-78419-003	E-14-18
HCO-93500-05020-4J	E-3-52	HGHB-16163-610	E-6-10-1	HPJ7-12204-305	E-9-2	H5K7-91566-003	E-1-29
HCO-93500-05065-4J	FOP-1-34	HHA0-90402-000	F-2-29	HPJ7-12205-305	E-9-3	H5L0-91592-A51	E-18-10-23
HCO-93500-05065-4J	FOP-1-2-39	HHE0-50310-003	E-1-13	HPK1-91308-003	E-3-46	H5TK-91540-003	FOP-10-3
HCO-93500-06018-4J	E-4-26	HHW1-90207-671	E-6-10-31	HPLC-91301-000	E-14-28	HVA9-87516-B50	F-12-9
HCO-93500-06025-4J	F-3-20-40	HHW1-90215-671	F-4-18	HPM3-14775-000	E-9-10-16	HVM0-16965-771	E-18-10-10
HCO-93600-06016-0A	E-5-19	HKE8-17251-690	F-8-1	HPM4-36145-004	E-14-10-9	HZA0-90684-601	F-8-10-36
HCO-93901-250J0	FOP-1-6-71	HKG4-90659-000	E-18-1-30	HPNA-91214-014	E-3-43	HZB7-90691-003	E-1-24
HCO-93901-251J0	FOP-1-6-72	HKM3-32161-003	F-10-6	HPNA-91302-003	E-14-29	HZB7-90691-003	E-18-54
HCO-93901-252J0	FOP-1-6-73	HKM3-32161-003	F-10-76	HPNA-91307-003	E-3-44	HZC0-63515-700	F-8-10-24
HCO-93903-262J0	FOP-1-6-74	HKN5-17224-670	F-2-1	HPNA-91307-003	E-4-24	HZE2-90601-000	E-6-13
HCO-93905-255J0	FOP-1-6-75	HKT7-91305-003	E-1-25	HPPA-90009-E01	E-18-46	HZV0-41122-000	E-13-19
HCO-93911-141J0	F-8-17	HKY7-17450-740	E-18-10-11	HPR3-91319-003	E-3-48	HZV0-90604-000	E-1-23
HCO-94001-05490-05	FOP-1-35	HMB1-90655-921	E-18-10-22	HPR7-31105-A01	E-19-1	HZV0-90604-000	E-18-1-28
HCO-94001-05490-05	FOP-1-2-40	HMG9-17201-000	E-14-10-7	HPR7-36361-A01	E-18-43	HZV1-24210-010	F-10-4
HCO-94001-06080-05	E-19-27	HMG9-35701-950	F-11-3	HPT0-14744-004	E-9-10-12	HZV4-12155-A00	E-3-4
HCO-94001-06490-05	FOP-1-6-76	HMG9-35701-950	FOP-1-6-40	HPT0-31111-003	E-19-2	HZV4-17704-010	F-8-20-4
HCO-94001-12490-05	F-10-72	HMJ0-91301-003	E-14-27	HPT0-31114-013	E-19-3	HZV4-24221-010	F-10-5
HCO-94002-05490-05	FOP-1-6-77	HMJ0-91301-003	E-18-55	HPT0-31118-003	E-19-4	HZV4-36182-651	FOP-1-6-42
HCO-94002-06490-05	F-8-18	HMJ0-91308-003	F-4-29	HPT0-31146-003	E-19-9	HZV4-36182-651	FOP-7-11
HCO-94103-05400	FOP-6-4	HMJ0-91308-003	FOP-14-7	HPT0-31147-003	E-19-11	HZV4-36182-651	FOP-7-1-9
HCO-94103-05400	FOP-7-21	HML0-90101-720	F-8-10-28	HPT0-31148-003	E-19-13	HZV4-36187-652	FOP-1-6-43
HCO-94103-05400	FOP-7-1-18	HMM4-90105-000	FOP-1-6-51	HPT0-90005-003	E-9-11	HZV4-36187-652	FOP-7-12
HCO-94111-05400	FOP-6-5	HMM8-90502-610	F-8-10-32	HPT0-90206-004	E-9-10-20	HZV4-36187-652	FOP-7-1-10
HCO-94111-05400	FOP-7-22	HMR5-16966-000	F-8-20-5	HPT0-90705-000	E-9-15	HZV4-90127-000	E-6-10
HCO-94111-05400	FOP-7-1-19	HMT2-17193-000	E-1-10	HPT2-91005-N01	F-5-23	HZV4-90127-000	F-2-27
HCO-94301-06100	E-3-53	HMT8-18334-770	FOP-6-2	HPW5-90701-000	E-5-15	HZV4-90302-000	F-3-19
HCO-94301-06100	E-13-30	HMT8-18334-770	FOP-7-2	HPW5-90701-000	E-6-20-9	HZV4-90304-000	FOP-1-6-55
HCO-94301-06100	E-15-28	HMT8-18334-770	FOP-7-1-2	HPY3-17249-000	E-15-7	HZV4-90502-000	FOP-1-31
HCO-94301-08140	E-3-10-18	HP01-91212-003	E-5-17	HPY3-31215-004	E-21-4	HZV4-90502-000	FOP-1-2-36
HCO-94301-10120	E-14-30	HP08-12342-004	E-1-4	HPY3-31218-004	E-21-6	HZV4-90502-000	FOP-1-6-58
HCO-94302-06100	E-9-18	HPOA-91303-A02	E-15-25	HPZ1-12210-004	E-9-4	HZV4-90506-000	F-2-31

HZV4-90512-000	...	F-2-34	HZV5-90502-000	...	F-10-55	HZW1-91361-701	...	F-11-49	HZW5-90103-U01	...	FOP-1-2-27
HZV4-90512-000	...	F-10-61	HZV5-90504-000	...	F-10-56	HZW1-91554-000	...	E-18-56	HZW5-90104-U00	...	FOP-1-25
HZV4-90514-000	...	F-10-62	HZV5-90552-000	...	F-10-63	HZW1-91554-000	...	F-8-10-38	HZW5-90104-U00	...	FOP-1-2-28
HZV4-90603-000	...	E-6-10-32	HZV5-90557-000	...	FOP-1-6-62	HZW1-91557-701	...	F-11-50	HZW5-90105-U01	...	FOP-1-26
HZV4-90605-000	...	E-6-10-33	HZV5-90559-000	...	E-6-20-7	HZW2-90003-000	...	E-20-10-7	HZW5-90105-U01	...	FOP-1-2-29
HZV4-90605-000	...	E-18-1-29	HZV5-90559-000	...	F-3-22	HZW2-90003-000	...	F-7-10-12	HZW5-90106-U00	...	FOP-1-27
HZV4-90605-000	...	F-3-20-47	HZV5-90559-000	...	F-3-20-45	HZW4-90108-000	...	FOP-1-6-52	HZW5-90106-U00	...	FOP-1-2-30
HZV5-12155-000	...	E-4-1	HZV5-90559-000	...	F-5-20	HZW4-90126-000	...	E-1-19	HZW5-90107-U00	...	FOP-1-28
HZV5-12214-000	...	E-3-8	HZV5-90559-000	...	F-10-64	HZW4-90147-000	...	E-3-10-14	HZW5-90107-U00	...	FOP-1-2-31
HZV5-12214-000	...	E-3-10-3	HZV5-90563-000	...	E-6-20-8	HZW4-90151-000	...	E-3-10-15	HZW5-90108-U00	...	FOP-1-2-32
HZV5-24811-010	...	FOP-1-6-2	HZV5-90563-000	...	F-3-20-46	HZW4-90155-000	...	E-4-19	HZW5-90109-000	...	FOP-6-3
HZV5-24812-000	...	FOP-1-6-3	HZV5-90651-000	...	F-10-66	HZW4-90156-000	...	E-3-40	HZW5-90109-000	...	FOP-7-18
HZV5-24813-000	...	FOP-1-6-4	HZV5-90751-000	...	FOP-1-6-63	HZW4-90156-000	...	E-14-10-18	HZW5-90109-000	...	FOP-7-1-15
HZV5-24814-010	...	FOP-1-6-5	HZV5-90756-000	...	F-3-24	HZW4-90306-003	...	F-10-51	HZW5-90203-010	...	E-19-25
HZV5-24815-010	...	FOP-1-6-6	HZV5-90756-000	...	F-3-20-50	HZW4-90401-000	...	FOP-1-6-56	HZW5-90301-U00	...	FOP-1-29
HZV5-24816-000	...	FOP-1-6-7	HZV5-90756-000	...	F-4-24	HZW4-90402-000	...	FOP-1-6-57	HZW5-90301-U00	...	FOP-1-2-33
HZV5-24817-000	...	FOP-1-6-8	HZV5-90772-000	...	FOP-1-6-64	HZW4-91301-003	...	F-3-25	HZW5-90302-003	...	F-10-48
HZV5-24818-003	...	FOP-1-6-9	HZV5-91151-000	...	FOP-1-6-65	HZW4-91301-003	...	FOP-14-6	HZW5-90302-U21	...	FOP-1-2-34
HZV5-24820-010	...	FOP-1-6-10	HZV5-91203-821	...	F-11-39	HZW5-06241-U00	...	FOP-1-2	HZW5-90501-U00	...	FOP-1-30
HZV5-24830-010	...	FOP-1-6-11	HZV5-91256-003	...	F-10-69	HZW5-06241-U10	...	FOP-1-2-2	HZW5-90501-U00	...	FOP-1-2-35
HZV5-24836-000	...	FOP-1-6-12	HZV5-91302-821	...	F-11-41	HZW5-06352-U01	...	FOP-6-1	HZW5-90501-U00	...	FOP-1-4-26
HZV5-24841-000	...	FOP-1-6-13	HZV5-91316-821	...	F-11-42	HZW5-06900-U00	...	FOP-5-1	HZW5-90502-U00	...	FOP-1-32
HZV5-24845-000	...	FOP-1-6-14	HZV5-91352-000	...	F-10-70	HZW5-16081-010	...	E-18-20	HZW5-90502-U00	...	FOP-1-2-37
HZV5-24850-000	...	FOP-1-6-15	HZV5-91553-010	...	E-15-26	HZW5-16086-000	...	E-18-23	HZW5-90503-U00	...	FOP-1-33
HZV5-24854-000	...	FOP-1-6-16	HZV5-91553-010	...	E-20-5	HZW5-16087-000	...	E-18-24	HZW5-90503-U00	...	FOP-1-2-38
HZV5-24855-000	...	FOP-1-6-17	HZV5-91553-010	...	E-20-10-11	HZW5-16715-023	...	E-18-29	HZW5-90509-711	...	F-5-16
HZV5-24860-000	...	FOP-1-6-18	HZV5-91553-010	...	F-7-10-25	HZW5-16733-000	...	E-18-34	HZW5-90511-U00	...	FOP-5-3
HZV5-24865-000	...	FOP-1-6-19	HZV5-91563-000	...	F-3-20-53	HZW5-16915-000	...	E-18-10-9	HZW5-90512-U00	...	FOP-5-4
HZV5-24875-000	...	FOP-1-6-20	HZV5-91567-000	...	FOP-1-6-67	HZW5-19291-000	...	E-6-10-9	HZW5-90601-030	...	E-18-10-19
HZV5-24876-000	...	FOP-1-6-21	HZV5-91570-000	...	FOP-1-6-68	HZW5-19292-000	...	E-6-10-11	HZW5-90602-030	...	E-1-21
HZV5-24878-000	...	FOP-1-6-22	HZV7-90508-000	...	F-2-32	HZW5-19297-000	...	E-6-10-15	HZW5-90602-030	...	E-18-10-20
HZV5-24881-000	...	FOP-1-6-23	HZV7-90951-010	...	F-10-68	HZW5-24810-U01	...	FOP-1-3	HZW5-91201-003	...	E-5-16
HZV5-24883-000	...	FOP-1-6-24	HZW1-06411-020	...	F-10-1	HZW5-24810-U01	...	FOP-1-2-3	HZW5-91202-003	...	E-6-10-35
HZV5-24884-000	...	FOP-1-6-25	HZW1-15631-000	...	E-3-10-6	HZW5-24810-U11	...	FOP-1-2-4	HZW5-91251-003	...	F-2-28
HZV5-24885-000	...	FOP-1-6-26	HZW1-19286-B00	...	F-3-1	HZW5-24811-U01	...	FOP-1-4	HZW7-24810-U01	...	FOP-1-4-2
HZV5-24887-000	...	FOP-1-6-27	HZW1-24210-010	...	F-2-5	HZW5-24811-U01	...	FOP-1-2-5	HZW7-24811-U01	...	FOP-1-4-3
HZV5-24891-000	...	FOP-1-6-28	HZW1-24327-000	...	F-2-7	HZW5-24812-U01	...	FOP-1-5	HZW7-24812-U01	...	FOP-1-4-4
HZV5-24892-000	...	FOP-1-6-29	HZW1-24343-B02	...	F-4-12	HZW5-24812-U01	...	FOP-1-2-6	HZW7-24813-U01	...	FOP-1-4-5
HZV5-24894-000	...	FOP-1-6-30	HZW1-24629-000	...	F-2-17	HZW5-24813-U01	...	FOP-1-6	HZW7-24814-U01	...	FOP-1-4-6
HZV5-24895-000	...	FOP-1-6-31	HZW1-31226-004	...	E-21-7	HZW5-24813-U01	...	FOP-1-2-7	HZW7-24815-U01	...	FOP-1-4-7
HZV5-24897-000	...	FOP-1-6-32	HZW1-31229-004	...	E-21-8	HZW5-24813-U21	...	FOP-1-2-8	HZW7-24817-U01	...	FOP-1-4-9
HZV5-24898-000	...	FOP-1-6-33	HZW1-31231-004	...	E-21-9	HZW5-24814-U01	...	FOP-1-7	HZW7-24832-U01	...	FOP-1-4-14
HZV5-32823-003	...	FOP-1-6-35	HZW1-36104-003	...	F-11-4	HZW5-24814-U01	...	FOP-1-2-9	HZW7-24833-U01	...	FOP-1-4-15
HZV5-32823-003	...	FOP-7-7	HZW1-38551-000	...	F-7-10-10	HZW5-24815-U01	...	FOP-1-8	HZW7-32530-U00	...	FOP-1-19
HZV5-32823-003	...	FOP-7-1-5	HZW1-40107-700	...	F-11-10	HZW5-24816-U01	...	FOP-1-9	HZW7-32530-U00	...	FOP-1-2-20
HZV5-32824-003	...	FOP-1-6-36	HZW1-40209-000	...	F-3-20-11	HZW5-24816-U01	...	FOP-1-2-10	HZW7-32530-U10	...	FOP-1-2-21
HZV5-32824-003	...	FOP-7-8	HZW1-41102-B00	...	F-3-4	HZW5-24816-U01	...	FOP-1-4-8	HZW7-32530-U20	...	FOP-1-4-16
HZV5-32824-003	...	FOP-7-1-6	HZW1-41109-B00	...	F-3-9	HZW5-24817-U01	...	FOP-1-10	HZW7-35370-U02	...	FOP-1-4-17
HZV5-35370-823	...	FOP-1-6-39	HZW1-56110-701	...	F-11-15	HZW5-24817-U01	...	FOP-1-2-11	HZW7-87703-U00	...	FOP-1-4-19
HZV5-36136-821	...	F-11-9	HZW1-56113-701	...	F-11-16	HZW5-24818-U01	...	FOP-1-11	HZW7-90101-U01	...	FOP-1-4-21
HZV5-36180-033	...	FOP-1-6-41	HZW1-56116-701	...	F-11-19	HZW5-24818-U01	...	FOP-1-2-12	HZW7-90102-U01	...	FOP-1-4-22
HZV5-36180-033	...	FOP-7-10	HZW1-56130-702	...	F-11-24	HZW5-24819-U01	...	FOP-1-12	HZW7-90103-U01	...	FOP-1-4-23
HZV5-36180-033	...	FOP-7-1-8	HZW1-56180-701	...	F-11-26	HZW5-24819-U01	...	FOP-1-2-13	HZW7-90104-U01	...	FOP-1-4-24
HZV5-38410-003	...	FOP-1-6-46	HZW1-56539-000	...	F-10-33	HZW5-24825-U01	...	FOP-1-14	HZW7-90301-U01	...	FOP-1-4-25
HZV5-38410-003	...	FOP-7-16	HZW1-56851-703	...	F-11-29	HZW5-24825-U01	...	FOP-1-2-15	HZW7-90502-U00	...	FOP-1-4-27
HZV5-38410-003	...	FOP-7-1-13	HZW1-56860-701	...	F-11-30	HZW5-24826-U01	...	FOP-1-15	HZW9-19279-000	...	E-6-10-8
HZV5-40102-000	...	E-15-18	HZW1-87538-721	...	F-12-10	HZW5-24826-U01	...	FOP-1-2-16	HZW9-19291-000	...	E-6-10-10
HZV5-40107-000	...	F-3-20-7	HZW1-90013-000	...	E-15-19	HZW5-24826-U01	...	FOP-1-4-10	HZW9-19297-000	...	E-6-10-16
HZV5-41171-000	...	F-10-10	HZW1-90013-000	...	F-7-10-13	HZW5-24831-U01	...	FOP-1-16	HZW9-32114-730	...	E-1-11
HZV5-41172-000	...	F-10-11	HZW1-90014-000	...	E-18-47	HZW5-24831-U01	...	FOP-1-2-17	HZW9-32114-730	...	E-3-21
HZV5-50214-003	...	F-11-12	HZW1-90102-000	...	F-10-36	HZW5-24831-U01	...	FOP-1-4-12	HZW9-35490-003	...	E-3-24
HZV5-56117-821	...	F-11-20	HZW1-90106-004	...	E-21-21	HZW5-24832-U01	...	FOP-1-17	HZW9-87702-800	...	FOP-1-6-49
HZV5-56118-820	...	F-11-21	HZW1-90107-004	...	E-21-22	HZW5-24832-U01	...	FOP-1-2-18	HZW9-90005-000	...	F-10-34
HZV5-56513-000	...	F-11-27	HZW1-90108-000	...	F-10-41	HZW5-24832-U01	...	FOP-1-4-13	HZW9-90008-000	...	FOP-1-6-50
HZV5-82873-003	...	F-3-20-30	HZW1-90113-702	...	F-11-31	HZW5-24834-U01	...	FOP-1-18	HZW9-90009-000	...	F-10-35
HZV5-90009-000	...	E-6-8	HZW1-90114-702	...	F-11-32	HZW5-24834-U21	...	FOP-1-2-19	HZW9-90011-000	...	E-1-16
HZV5-90009-000	...	F-8-10-26	HZW1-90115-702	...	F-11-33	HZW5-32168-003	...	E-18-42	HZW9-90011-000	...	E-13-20
HZV5-90012-013	...	E-13-21	HZW1-90116-702	...	F-11-34	HZW5-35370-U02	...	FOP-1-20	HZW9-90011-000	...	F-2-22
HZV5-90081-010	...	E-3-39	HZW1-90203-000	...	F-7-10-17	HZW5-35370-U02	...	FOP-1-2-22	HZW9-90013-000	...	F-7-3
HZV5-90081-010	...	E-3-10-12	HZW1-90301-B00	...	F-5-14	HZW5-35370-U12	...	FOP-1-2-23	HZW9-90013-000	...	F-7-10-14
HZV5-90081-010	...	E-5-25	HZW1-90304-013	...	F-10-50	HZW5-35665-003	...	E-15-16	HZW9-90014-000	...	E-18-1-25
HZV5-90110-000	...	F-3-20-34	HZW1-90308-003	...	F-3-21	HZW5-90002-013	...	E-5-14	HZW9-90014-000	...	E-20-10-8
HZV5-90119-000	...	F-10-44	HZW1-90401-000	...	E-6-12	HZW5-90011-010	...	E-19-22	HZW9-90014-000	...	F-7-10-15
HZV5-90119-000	...	F-10-77	HZW1-90652-702	...	F-11-38	HZW5-90018-000	...	E-20-10-9	HZW9-90016-000	...	E-14-19
HZV5-90119-000	...	F-11-35	HZW1-90758-B00	...	F-5-22	HZW5-90018-000	...	F-7-20-7	HZW9-90016-000	...	E-18-48
HZV5-90125-000	...	FOP-1-6-53	HZW1-90758-B00	...	FOP-14-2	HZW5-90021-U00	...	FOP-5-2	HZW9-90019-000	...	E-1-17
HZV5-90127-003	...	F-10-45	HZW1-91207-013	...	F-11-40	HZW5-90023-000	...	F-2-24	HZW9-90019-000	...	E-3-34
HZV5-90127-003	...	F-11-36	HZW1-91352-702	...	F-11-43	HZW5-90101-U00	...	FOP-1-22	HZW9-90019-000	...	E-4-16
HZV5-90131-000	...	E-6-11	HZW1-91353-703	...	F-11-44	HZW5-90101-U00	...	FOP-1-2-25	HZW9-90019-000	...	E-14-20
HZV5-90302-003	...	F-2-28	HZW1-91354-701	...	F-11-45	HZW5-90101-U00	...	FOP-1-4-20	HZW9-90101-003	...	F-3-10
HZV5-90304-013	...	F-10-49	HZW1-91355-701	...	F-11-46	HZW5-90102-U00	...	FOP-1-23	HZW9-90102-000	...	F-2-26
HZV5-90307-003	...	F-10-52	HZW1-91357-701	...	F-11-47	HZW5-90102-U00	...	FOP-1-2-26	HZW9-90102-000	...	F-8-10-29
HZV5-90501-000	...	F-10-53	HZW1-91358-701	...	F-11-48	HZW5-90103-U01	...	FOP-1-24	HZW9-90103-010	...	F-10-37

HZW9-90105-000 . . . . . F-8-11  
 HZW9-90105-000 . . . . . F-8-10-30  
 HZW9-90105-000 . . . . . F-10-40  
 HZW9-90506-000 . . . . . F-8-10-34  
 HZX1-90133-R00 . . . . . F-8-13  
 HZX2-06125-C00 . . . . . FOP-14-1  
 HZX2-06131-000 . . . . . E-7-16  
 HZX2-06192-C00 . . . . . F-4-35  
 HZX2-06193-C00 . . . . . F-4-36  
 HZX2-11381-003 . . . . . E-6-2  
 HZX2-11911-000 . . . . . E-3-10-2  
 HZX2-12000-405ZA . . . . . E-3-3  
 HZX2-13010-000 . . . . . E-7-1  
 HZX2-13101-000 . . . . . E-7-2  
 HZX2-13321-003 . . . . . E-7-10  
 HZX2-13322-003 . . . . . E-7-  
 HZX2-13323-003 . . . . . E-7-  
 HZX2-13324-003 . . . . . E-7-  
 HZX2-13325-003 . . . . . E-7-  
 HZX2-13326-003 . . . . . E-7-  
 HZX2-13341-003 . . . . . E-7-12  
 HZX2-13342-003 . . . . . E-7-  
 HZX2-13343-003 . . . . . E-7-  
 HZX2-13344-003 . . . . . E-7-  
 HZX2-13345-003 . . . . . E-7-  
 HZX2-13346-003 . . . . . E-7-  
 HZX2-13392-000 . . . . . E-7-14  
 HZX2-13811-000 . . . . . E-13-3  
 HZX2-14111-000 . . . . . E-9-10-1  
 HZX2-14211-000 . . . . . E-9-10-2  
 HZX2-14526-405ZA . . . . . E-13-10  
 HZX2-15655-000 . . . . . E-3-15  
 HZX2-16020-003 . . . . . E-18-4  
 HZX2-16024-003 . . . . . E-18-1-34  
 HZX2-16030-003 . . . . . E-18-7  
 HZX2-16404-000 . . . . . E-15-4  
 HZX2-16700-003 . . . . . E-1-7  
 HZX2-16701-003 . . . . . E-18-27  
 HZX2-16730-003 . . . . . E-18-33  
 HZX2-16800-003 . . . . . E-18-1-4  
 HZX2-16805-003 . . . . . E-18-1-5  
 HZX2-16814-000 . . . . . E-18-1-7  
 HZX2-16850-000 . . . . . F-8-20-1  
 HZX2-16860-000 . . . . . E-18-1-8  
 HZX2-16870-000 . . . . . E-1-8  
 HZX2-16880-000 . . . . . E-18-1-9  
 HZX2-16890-000 . . . . . E-18-1-10  
 HZX2-16900-003 . . . . . E-18-1-11  
 HZX2-16912-003 . . . . . E-18-1-16  
 HZX2-16914-000 . . . . . E-18-1-17  
 HZX2-16940-003 . . . . . E-18-1-24  
 HZX2-17374-000 . . . . . E-15-9  
 HZX2-19234-C00 . . . . . F-4-5  
 HZX2-19241-C00 . . . . . F-4-6  
 HZX2-19300-003 . . . . . E-4-10  
 HZX2-19303-003 . . . . . E-4-11  
 HZX2-19313-000ZA . . . . . E-4-12  
 HZX2-19315-000ZA . . . . . E-4-13  
 HZX2-19511-000 . . . . . E-13-16  
 HZX2-19540-010 . . . . . E-15-29  
 HZX2-24101-C00 . . . . . F-5-1  
 HZX2-30416-000 . . . . . E-20-10-1  
 HZX2-30520-003 . . . . . E-20-2  
 HZX2-31110-000ZA . . . . . E-5-11  
 HZX2-31916-003 . . . . . E-20-3  
 HZX2-32100-010 . . . . . F-7-1  
 HZX2-32166-003 . . . . . E-18-41  
 HZX2-32370-004 . . . . . F-7-20-1  
 HZX2-32410-000 . . . . . F-7-10-3  
 HZX2-32414-300 . . . . . F-7-10-5  
 HZX2-32415-000 . . . . . F-7-10-7  
 HZX2-32435-000 . . . . . F-7-10-8  
 HZX2-34750-023 . . . . . E-20-10-4  
 HZX2-35470-013 . . . . . F-2-18  
 HZX2-36120-003 . . . . . F-11-5  
 HZX2-36129-003 . . . . . F-11-8  
 HZX2-38228-003 . . . . . F-7-20-3  
 HZX2-38550-003 . . . . . F-7-10-9  
 HZX2-38552-000 . . . . . F-7-10-11  
 HZX2-41100-C11ZC . . . . . F-3-10-1  
 HZX2-41101-C01ZC . . . . . F-3-3  
 HZX2-41107-C00ZC . . . . . F-3-8  
 HZX2-41112-C10 . . . . . F-4-14  
 HZX2-41131-C00 . . . . . F-4-16  
 HZX2-41140-C00 . . . . . F-5-8  
 HZX2-41151-C00 . . . . . F-5-9  
 HZX2-41161-C00 . . . . . F-5-10  
 HZX2-41201-C00ZC . . . . . F-5-11  
 HZX2-41202-C00 . . . . . F-5-12  
 HZX2-56000-013 . . . . . F-11-13  
 HZX2-58130-T01 . . . . . FOP-12-1  
 HZX2-58130-T11 . . . . . FOP-12-  
 HZX2-58130-T21 . . . . . FOP-12-  
 HZX2-58130-T31 . . . . . FOP-12-  
 HZX2-58130-T41 . . . . . FOP-12-  
 HZX2-58130-T51 . . . . . FOP-12-  
 HZX2-58130-T61 . . . . . FOP-12-  
 HZX2-63100-R00ZA . . . . . F-8-2  
 HZX2-63111-C00ZB . . . . . F-8-6  
 HZX2-63119-C00 . . . . . F-8-7  
 HZX2-63260-C00 . . . . . F-8-10-23  
 HZX2-63710-C00ZB . . . . . F-3-20-20  
 HZX2-63715-C00ZB . . . . . F-3-20-21  
 HZX2-63719-C00 . . . . . F-3-20-23  
 HZX2-87117-T60 . . . . . F-12-2  
 HZX2-87121-R00 . . . . . F-12-3  
 HZX2-90001-000 . . . . . E-5-13  
 HZX2-90002-000 . . . . . E-19-21  
 HZX2-90101-C00 . . . . . F-2-25  
 HZX2-90102-C00 . . . . . F-3-20-31  
 HZX2-90105-C00 . . . . . F-4-17  
 HZX2-90107-C00 . . . . . F-3-13  
 HZX2-90129-000 . . . . . F-10-46  
 HZX2-90301-C00 . . . . . F-4-19  
 HZX2-90303-C00 . . . . . F-4-20  
 HZX2-90502-003 . . . . . F-8-10-33  
 HZX2-90518-C00 . . . . . F-4-22  
 HZX2-90519-C00 . . . . . F-4-  
 HZX2-90520-C00 . . . . . F-4-  
 HZX2-90521-C00 . . . . . F-4-  
 HZX2-90528-C00 . . . . . F-5-18  
 HZX2-90529-C00 . . . . . F-5-  
 HZX2-90530-C00 . . . . . F-5-  
 HZX2-90531-C00 . . . . . F-5-  
 HZX2-90651-C00 . . . . . F-5-21  
 HZX2-90683-003 . . . . . E-18-1-32  
 HZX2-90683-003 . . . . . F-7-10-22  
 HZX2-91051-C01 . . . . . F-5-24  
 HZX2-91053-C01 . . . . . F-4-25  
 HZX2-91055-C01 . . . . . F-5-25  
 HZX2-91056-C01 . . . . . F-4-26  
 HZX2-91351-C00 . . . . . F-5-30  
 HZX2-91351-C00 . . . . . FOP-14-8  
 HZX2-91358-C00 . . . . . F-4-31  
 HZX2-91359-C00 . . . . . F-4-32  
 HZY1-90205-000 . . . . . F-3-18  
 HZY1-90205-000 . . . . . F-10-47  
 HZY1-90650-003 . . . . . FOP-10-2  
 HZY2-87132-R00 . . . . . F-12-4  
 HZY2-87133-R00 . . . . . F-12-15  
 HZY3-06177-U02 . . . . . FOP-8-1  
 HZY3-06412-000 . . . . . F-10-2  
 HZY3-06532-U00 . . . . . F-10-3  
 HZY3-11100-415 . . . . . E-3-10-1  
 HZY3-11200-010ZA . . . . . E-3-1  
 HZY3-11300-C00 . . . . . E-3-2  
 HZY3-11311-010ZA . . . . . E-6-1  
 HZY3-11820-000 . . . . . E-13-10-2  
 HZY3-11840-010 . . . . . E-13-10-3  
 HZY3-11861-000 . . . . . E-13-10-4  
 HZY3-11871-000 . . . . . E-13-10-5  
 HZY3-11911-010 . . . . . E-9-1  
 HZY3-12155-000 . . . . . E-3-5  
 HZY3-12164-000 . . . . . E-3-6  
 HZY3-12171-305 . . . . . E-3-7  
 HZY3-12210-010ZA . . . . . E-9-5  
 HZY3-12231-000 . . . . . E-9-7  
 HZY3-12241-000 . . . . . E-9-8  
 HZY3-12251-A01 . . . . . E-9-9  
 HZY3-12310-405ZA . . . . . E-1-1  
 HZY3-12312-000 . . . . . E-1-2  
 HZY3-12320-405ZA . . . . . E-1-3  
 HZY3-13331-A03 . . . . . E-7-11  
 HZY3-13331-A04 . . . . . E-7-  
 HZY3-13391-000 . . . . . E-7-13  
 HZY3-13398-003 . . . . . E-7-15  
 HZY3-13621-C01 . . . . . E-13-1  
 HZY3-13622-C00 . . . . . E-13-2  
 HZY3-14261-C00 . . . . . E-13-4  
 HZY3-14270-C00 . . . . . E-13-5  
 HZY3-14436-000 . . . . . E-9-10-3  
 HZY3-14510-003 . . . . . E-13-7  
 HZY3-14515-000 . . . . . E-13-8  
 HZY3-14520-000 . . . . . E-13-9  
 HZY3-14529-000 . . . . . E-13-11  
 HZY3-14550-003 . . . . . E-13-12  
 HZY3-14553-003 . . . . . E-13-14  
 HZY3-14555-003 . . . . . E-13-15  
 HZY3-15100-000ZA . . . . . E-5-1  
 HZY3-15112-013 . . . . . E-5-2  
 HZY3-15113-000 . . . . . E-5-3  
 HZY3-15121-000 . . . . . E-5-4  
 HZY3-15131-405 . . . . . E-5-5  
 HZY3-15132-405 . . . . . E-5-6  
 HZY3-15220-020 . . . . . E-5-7  
 HZY3-15425-010 . . . . . E-1-5  
 HZY3-15656-000 . . . . . E-3-16  
 HZY3-15657-000 . . . . . E-3-17  
 HZY3-15810-003ZA . . . . . E-3-18  
 HZY3-15825-003 . . . . . E-3-19  
 HZY3-16011-A01 . . . . . E-18-1  
 HZY3-16013-000 . . . . . E-18-2  
 HZY3-16015-000 . . . . . E-18-3  
 HZY3-16016-003 . . . . . E-15-1  
 HZY3-16024-000 . . . . . E-18-5  
 HZY3-16026-000 . . . . . E-18-6  
 HZY3-16031-010 . . . . . E-18-8  
 HZY3-16036-003 . . . . . E-18-9  
 HZY3-16041-000 . . . . . E-18-10  
 HZY3-16042-000 . . . . . E-18-11  
 HZY3-16061-000 . . . . . E-18-12  
 HZY3-16072-000 . . . . . E-18-13  
 HZY3-16073-000 . . . . . E-18-14  
 HZY3-16074-000 . . . . . E-18-15  
 HZY3-16075-000 . . . . . E-18-16  
 HZY3-16076-000 . . . . . E-18-17  
 HZY3-16077-000 . . . . . E-18-18  
 HZY3-16078-000 . . . . . E-18-19  
 HZY3-16082-000 . . . . . E-18-21  
 HZY3-16083-000 . . . . . E-18-22  
 HZY3-16087-000 . . . . . E-18-25  
 HZY3-16088-000 . . . . . E-18-26  
 HZY3-16176-000 . . . . . E-15-2  
 HZY3-16193-A00 . . . . . E-18-10-2  
 HZY3-16196-A00 . . . . . E-18-10-3  
 HZY3-16197-000 . . . . . E-18-10-4  
 HZY3-16198-A00 . . . . . E-18-10-5  
 HZY3-16199-A00 . . . . . E-18-10-6  
 HZY3-16203-000 . . . . . E-1-6  
 HZY3-16400-A01 . . . . . E-15-3  
 HZY3-16405-000 . . . . . E-15-5  
 HZY3-16451-000 . . . . . E-14-2  
 HZY3-16611-A00 . . . . . E-14-3  
 HZY3-16620-A00 . . . . . E-14-5  
 HZY3-16708-000 . . . . . E-18-28  
 HZY3-16721-000 . . . . . E-18-31  
 HZY3-16733-000 . . . . . E-18-35  
 HZY3-16734-000 . . . . . E-18-36  
 HZY3-16735-004 . . . . . E-18-37  
 HZY3-16740-A01 . . . . . E-14-6  
 HZY3-16751-000 . . . . . E-18-10-7  
 HZY3-16752-000 . . . . . E-18-38  
 HZY3-16752-A00 . . . . . E-14-8  
 HZY3-16753-000 . . . . . E-18-1-2  
 HZY3-16754-000 . . . . . E-18-1-3  
 HZY3-16755-003 . . . . . E-14-9  
 HZY3-16757-003 . . . . . E-14-10  
 HZY3-16807-003 . . . . . E-18-1-6  
 HZY3-16895-000 . . . . . E-1-9  
 HZY3-16904-003 . . . . . E-18-1-14  
 HZY3-16911-010 . . . . . E-18-39  
 HZY3-16913-000 . . . . . E-18-40  
 HZY3-16915-010 . . . . . E-18-1-18  
 HZY3-16918-003 . . . . . E-18-1-20  
 HZY3-16919-003 . . . . . E-18-1-22  
 HZY3-17051-A00 . . . . . E-14-11  
 HZY3-17061-A00 . . . . . E-14-13  
 HZY3-17105-004 . . . . . E-14-10-1  
 HZY3-17108-000 . . . . . E-14-16  
 HZY3-17109-004 . . . . . E-14-10-2  
 HZY3-17110-003 . . . . . E-14-10-3  
 HZY3-17113-003 . . . . . E-14-10-4  
 HZY3-17130-003ZA . . . . . E-14-10-5  
 HZY3-17138-004 . . . . . E-14-10-6  
 HZY3-17721-000 . . . . . E-18-10-12  
 HZY3-17723-A01 . . . . . E-18-10-13  
 HZY3-17724-010 . . . . . E-18-10-14  
 HZY3-17738-000 . . . . . F-8-20-2  
 HZY3-17748-U01 . . . . . FOP-8-2  
 HZY3-17749-U01 . . . . . FOP-8-3  
 HZY3-17877-000 . . . . . F-2-2  
 HZY3-17910-013 . . . . . E-15-10  
 HZY3-17931-000 . . . . . F-2-3  
 HZY3-18110-010ZA . . . . . E-4-2  
 HZY3-18115-003 . . . . . E-4-3  
 HZY3-18120-C01ZA . . . . . E-4-4  
 HZY3-18125-003 . . . . . E-4-5  
 HZY3-18141-A00ZA . . . . . E-6-10-2  
 HZY3-18148-003 . . . . . E-6-10-3  
 HZY3-18149-A01 . . . . . E-6-10-4  
 HZY3-18151-A00ZA . . . . . E-6-10-5  
 HZY3-18330-020 . . . . . E-6-3  
 HZY3-18333-003 . . . . . E-6-4  
 HZY3-18340-020 . . . . . E-6-5  
 HZY3-19210-003 . . . . . F-4-1  
 HZY3-19221-010 . . . . . F-4-2  
 HZY3-19223-000 . . . . . F-4-3  
 HZY3-19231-000 . . . . . F-4-4  
 HZY3-19251-611 . . . . . F-4-7  
 HZY3-19252-000 . . . . . E-6-6  
 HZY3-19253-000 . . . . . F-4-8  
 HZY3-19254-000 . . . . . E-6-7  
 HZY3-19255-000 . . . . . E-4-6  
 HZY3-19256-010 . . . . . E-4-7  
 HZY3-19257-000 . . . . . E-4-8  
 HZY3-19258-010 . . . . . E-18-10-15  
 HZY3-19259-000 . . . . . E-18-10-16  
 HZY3-19261-000 . . . . . E-4-9  
 HZY3-19270-000 . . . . . F-3-20-1  
 HZY3-19271-000 . . . . . F-3-20-2  
 HZY3-19272-000 . . . . . F-3-20-3  
 HZY3-19277-000ZA . . . . . E-6-10-6  
 HZY3-19278-000 . . . . . E-6-10-7  
 HZY3-19289-000 . . . . . F-3-20-4  
 HZY3-19294-000ZB . . . . . E-6-10-12  
 HZY3-19295-000 . . . . . E-6-10-13  
 HZY3-19296-000 . . . . . E-6-10-14  
 HZY3-19297-000 . . . . . E-6-10-17  
 HZY3-19298-000ZB . . . . . E-6-10-18  
 HZY3-19361-000 . . . . . E-6-10-19  
 HZY3-19362-000 . . . . . E-6-10-20  
 HZY3-19366-000 . . . . . E-6-10-21  
 HZY3-23170-030ZA . . . . . E-6-10-22  
 HZY3-23172-003 . . . . . E-6-20-1  
 HZY3-23173-010 . . . . . E-6-10-23  
 HZY3-24102-000 . . . . . F-5-2  
 HZY3-24103-000 . . . . . F-5-3  
 HZY3-24113-A01 . . . . . F-5-4  
 HZY3-24122-A01 . . . . . F-5-5  
 HZY3-24123-000 . . . . . F-5-6  
 HZY3-24124-310 . . . . . F-5-7  
 HZY3-24221-000 . . . . . F-2-6  
 HZY3-24310-C00 . . . . . F-4-9  
 HZY3-24318-000 . . . . . F-4-10  
 HZY3-24610-A00 . . . . . F-2-8  
 HZY3-24612-010 . . . . . F-2-9  
 HZY3-24613-000 . . . . . F-2-10  
 HZY3-24617-000 . . . . . F-2-11  
 HZY3-24618-000 . . . . . F-2-12  
 HZY3-24619-000 . . . . . F-2-13  
 HZY3-24620-000 . . . . . F-2-14  
 HZY3-24623-000 . . . . . F-2-15  
 HZY3-24628-000 . . . . . F-2-16  
 HZY3-30280-003 . . . . . F-11-1  
 HZY3-31106-003 . . . . . F-11-2  
 HZY3-31116-000 . . . . . E-5-12  
 HZY3-31200-003 . . . . . E-21-1  
 HZY3-31207-003 . . . . . E-21-3  
 HZY3-31216-003 . . . . . E-21-5  
 HZY3-31226-003 . . . . . E-21-  
 HZY3-31232-003 . . . . . E-21-  
 HZY3-31235-003 . . . . . E-21-10

HZY3-31236-003. . . . .	E-21-11	HZY3-50388-U00 . . . . .	FOP-9-1	HZY3-90047-000. . . . .	E-6-10-28	HZY3-91356-003. . . . .	F-4-30
HZY3-31240-003. . . . .	E-21-12	HZY3-50388-U10 . . . . .	FOP-9-2	HZY3-90049-000. . . . .	E-6-10-29	HZY3-91401-A00 . . . . .	E-1-26
HZY3-31241-003. . . . .	E-21-	HZY3-50522-000. . . . .	F-10-27	HZY3-90050-000. . . . .	E-18-51	HZY3-91402-020. . . . .	E-1-27
HZY3-31242-003. . . . .	E-21-13	HZY3-50527-000. . . . .	F-10-28	HZY3-90053-010. . . . .	E-6-9	HZY3-91403-000. . . . .	E-1-28
HZY3-31243-003. . . . .	E-21-	HZY3-50529-000. . . . .	F-10-29	HZY3-90054-000. . . . .	E-18-52	HZY3-91404-000. . . . .	E-6-10-40
HZY3-31246-003. . . . .	E-21-15	HZY3-56100-013. . . . .	F-11-14	HZY3-90055-000. . . . .	E-19-24	HZY3-91405-000. . . . .	E-6-10-41
HZY3-31247-003. . . . .	E-21-16	HZY3-56120-013. . . . .	F-11-22	HZY3-90056-000. . . . .	E-18-1-26	HZY3-91451-000. . . . .	F-3-20-51
HZY3-31249-003. . . . .	E-21-17	HZY3-56170-013. . . . .	F-11-25	HZY3-90058-000. . . . .	E-14-10-17	HZY3-91508-000. . . . .	E-13-10-10
HZY3-31250-003. . . . .	E-21-18	HZY3-56516-A00 . . . . .	F-10-30	HZY3-90059-000. . . . .	E-6-10-30	HZY3-91551-000. . . . .	F-4-33
HZY3-31251-003. . . . .	E-21-24	HZY3-56518-A00 . . . . .	F-10-31	HZY3-90063-000. . . . .	E-3-10-11	HZY3-91556-000. . . . .	F-8-16
HZY3-31630-003. . . . .	E-19-14	HZY3-56519-A00 . . . . .	F-10-32	HZY3-90082-003. . . . .	E-3-10-13	HZY3-91560-000. . . . .	F-10-71
HZY3-31631-003. . . . .	E-19-15	HZY3-56532-000. . . . .	F-11-28	HZY3-90102-A00 . . . . .	F-3-20-32	HZY3-91651-003. . . . .	F-3-20-54
HZY3-31637-000. . . . .	E-19-16	HZY3-60180-C01 . . . . .	F-8-10-12	HZY3-90104-010. . . . .	F-10-39	HZY6-16450-003. . . . .	E-14-1
HZY3-31638-003. . . . .	E-13-17	HZY3-60185-C01 . . . . .	F-8-10-13	HZY3-90105-010. . . . .	F-3-20-33	HZY6-16718-013. . . . .	E-18-30
HZY3-31639-003. . . . .	E-19-17	HZY3-63102-010. . . . .	F-8-3	HZY3-90106-A00 . . . . .	F-8-10-31	HZY6-16723-003. . . . .	E-18-32
HZY3-31694-003. . . . .	E-19-18	HZY3-63107-000. . . . .	F-8-4	HZY3-90107-000. . . . .	F-7-10-16	HZY6-19269-000. . . . .	E-18-10-17
HZY3-31710-003. . . . .	E-19-19	HZY3-63108-000. . . . .	F-8-5	HZY3-90109-010. . . . .	F-8-12	HZY6-24320-610. . . . .	F-4-11
HZY3-31750-003. . . . .	E-19-20	HZY3-63201-000ZC. . . . .	F-8-10-14	HZY3-90111-000. . . . .	F-3-20-35	HZY6-32371-004. . . . .	F-7-20-2
HZY3-32111-010. . . . .	E-13-18	HZY3-63205-000. . . . .	F-8-10-15	HZY3-90113-C00 . . . . .	F-3-20-36	HZY6-32414-600. . . . .	F-7-10-6
HZY3-32112-000. . . . .	E-14-17	HZY3-63208-000. . . . .	F-8-10-16	HZY3-90117-000. . . . .	F-10-43	HZY6-36135-003. . . . .	E-18-10-18
HZY3-32116-000. . . . .	E-3-22	HZY3-63212-000. . . . .	F-8-10-17	HZY3-90120-000. . . . .	F-3-14	HZY6-38235-004. . . . .	F-7-20-4
HZY3-32128-000. . . . .	E-14-10-8	HZY3-63223-000. . . . .	F-8-10-18	HZY3-90122-000. . . . .	F-3-20-37	HZY6-39794-003. . . . .	F-7-20-6
HZY3-32129-000. . . . .	E-1-12	HZY3-63224-000. . . . .	F-8-10-19	HZY3-90123-000. . . . .	F-5-13	HZY6-90103-000. . . . .	F-3-12
HZY3-32193-C00 . . . . .	E-3-23	HZY3-63225-000. . . . .	F-8-10-20	HZY3-90124-000. . . . .	F-3-15	HZY6-90103-000. . . . .	F-10-38
HZY3-32411-003. . . . .	F-7-10-4	HZY3-63226-000. . . . .	F-8-10-21	HZY3-90129-A00 . . . . .	F-3-20-38	HZY6-90135-004. . . . .	F-7-20-8
HZY3-32419-A00 . . . . .	F-8-10-1	HZY3-63230-C00 . . . . .	F-8-10-22	HZY3-90132-000. . . . .	F-3-20-39	HZY6-91553-000. . . . .	F-3-20-52
HZY3-32421-000. . . . .	F-8-10-2	HZY3-63347-C00 . . . . .	F-3-20-19	HZY3-90204-000. . . . .	E-3-10-16	HZY9-17315-000. . . . .	E-15-8
HZY3-34754-C00 . . . . .	E-20-10-5	HZY3-63718-000. . . . .	F-3-20-22	HZY3-90205-000. . . . .	E-14-25	HZY9-30419-003. . . . .	E-20-1
HZY3-35476-010. . . . .	F-2-19	HZY3-63722-010ZC. . . . .	F-3-20-24	HZY3-90205-000. . . . .	E-14-10-19	HZY9-30419-003. . . . .	E-20-10-2
HZY3-35477-000. . . . .	F-2-20	HZY3-63728-000. . . . .	F-3-20-25	HZY3-90302-000. . . . .	F-3-20-42	HZY9-30419-003. . . . .	F-7-10-1
HZY3-35490-004. . . . .	E-3-25	HZY3-63729-003. . . . .	F-8-10-25	HZY3-90304-000. . . . .	F-7-10-18	HZY9-31207-H01 . . . . .	E-21-
HZY3-35640-013. . . . .	F-3-20-5	HZY3-63731-A12ZC. . . . .	F-3-20-26	HZY3-90405-000. . . . .	F-7-10-19	HZY9-31226-H01 . . . . .	E-21-
HZY3-35645-000. . . . .	F-3-20-6	HZY3-63736-A12ZC. . . . .	F-3-20-27	HZY3-90406-000. . . . .	E-1-20	HZY9-31229-H01 . . . . .	E-21-
HZY3-35655-C01 . . . . .	E-4-14	HZY3-63751-C00 . . . . .	F-3-20-28	HZY3-90501-A00 . . . . .	F-10-54	HZY9-31246-H01 . . . . .	E-21-
HZY3-35660-003. . . . .	F-10-7	HZY3-63756-C00 . . . . .	F-3-20-29	HZY3-90503-610. . . . .	F-3-20-43	HZY9-32103-000. . . . .	F-7-10-2
HZY3-35673-003. . . . .	E-3-26	HZY3-90001-000. . . . .	E-3-28	HZY3-90504-A00 . . . . .	F-10-57	HZY9-38553-003. . . . .	E-20-10-6
HZY3-35673-003. . . . .	E-4-15	HZY3-90002-000. . . . .	E-21-19	HZY3-90506-000. . . . .	F-5-15	HZY9-56115-003. . . . .	F-11-18
HZY3-35695-003. . . . .	E-13-10-6	HZY3-90003-000. . . . .	E-21-20	HZY3-90507-000. . . . .	F-8-15	HZY9-87538-U80 . . . . .	F-12-13
HZY3-35700-003. . . . .	E-3-27	HZY3-90006-003. . . . .	E-3-29	HZY3-90508-000. . . . .	E-15-24	HZY9-90017-000. . . . .	E-15-20
HZY3-36122-013. . . . .	F-11-6	HZY3-90007-000. . . . .	E-13-10-7	HZY3-90508-000. . . . .	F-2-33	HZY9-90105-000. . . . .	E-20-4
HZY3-36123-013. . . . .	F-11-7	HZY3-90008-003. . . . .	E-3-30	HZY3-90509-000. . . . .	F-10-58	HZZ0-90101-000. . . . .	F-3-11
HZY3-36163-003. . . . .	E-14-10-10	HZY3-90009-003. . . . .	E-3-31	HZY3-90510-000. . . . .	F-10-59	HZZ3-06240-R30 . . . . .	FOP-1-1
HZY3-36362-000. . . . .	E-18-44	HZY3-90010-000. . . . .	E-6-20-3	HZY3-90511-000. . . . .	F-3-20-44	HZZ3-06240-R40 . . . . .	FOP-1-4-1
HZY3-36550-003. . . . .	E-15-17	HZY3-90011-000. . . . .	E-6-20-4	HZY3-90512-000. . . . .	F-5-17	HZZ3-06240-R60 . . . . .	FOP-1-2-1
HZY3-36620-000. . . . .	E-18-45	HZY3-90013-000. . . . .	E-6-20-5	HZY3-90548-000. . . . .	F-5-19	HZZ3-06323-R00 . . . . .	FOP-7-
HZY3-40105-C01 . . . . .	F-8-10-3	HZY3-90015-000. . . . .	E-6-20-6	HZY3-90549-000. . . . .	F-5-	HZZ3-06323-R10 . . . . .	FOP-7-1-
HZY3-40114-010. . . . .	F-3-20-8	HZY3-90017-000. . . . .	E-3-33	HZY3-90550-000. . . . .	F-5-	HZZ3-06323-R20 . . . . .	FOP-7-1-
HZY3-40119-003. . . . .	F-8-10-4	HZY3-90017-000. . . . .	E-13-23	HZY3-90551-000. . . . .	F-5-	HZZ3-06323-R30 . . . . .	FOP-7-1-1
HZY3-40151-000ZC. . . . .	F-3-20-9	HZY3-90017-000. . . . .	E-18-49	HZY3-90552-000. . . . .	F-5-	HZZ3-06328-762. . . . .	FOP-10-1
HZY3-40154-000ZA. . . . .	F-8-10-5	HZY3-90017-000. . . . .	E-19-23	HZY3-90553-000. . . . .	F-5-	HZZ3-24800-R00 . . . . .	FOP-1-6-1
HZY3-40155-000. . . . .	F-8-10-6	HZY3-90017-000. . . . .	F-2-23	HZY3-90554-000. . . . .	F-5-	HZZ3-24800-R50 . . . . .	FOP-1-6-
HZY3-40157-000. . . . .	F-8-10-7	HZY3-90018-000. . . . .	E-13-10-9	HZY3-90555-000. . . . .	F-5-	HZZ3-24820-R11 . . . . .	FOP-1-13
HZY3-40158-000. . . . .	F-8-10-8	HZY3-90021-000. . . . .	E-3-35	HZY3-90556-000. . . . .	F-5-	HZZ3-24820-R21 . . . . .	FOP-1-2-14
HZY3-40159-000. . . . .	F-8-10-9	HZY3-90021-000. . . . .	E-14-21	HZY3-90557-000. . . . .	F-5-	HZZ3-24830-R41 . . . . .	FOP-1-4-11
HZY3-40201-612ZC. . . . .	F-3-20-10	HZY3-90021-000. . . . .	E-18-50	HZY3-90558-000. . . . .	F-5-	HZZ3-32101-000. . . . .	E-20-10-3
HZY3-40204-000. . . . .	F-4-13	HZY3-90021-000. . . . .	F-8-10-27	HZY3-90559-000. . . . .	F-5-	HZZ3-32127-000. . . . .	F-7-2
HZY3-40210-610. . . . .	F-3-20-12	HZY3-90023-000. . . . .	E-14-10-14	HZY3-90560-000. . . . .	F-5-	HZZ3-32341-R01 . . . . .	FOP-7-
HZY3-40212-611ZC. . . . .	F-3-20-13	HZY3-90026-000. . . . .	E-9-12	HZY3-90601-030. . . . .	E-4-20	HZZ3-32341-R31 . . . . .	FOP-7-3
HZY3-40219-013. . . . .	F-10-9	HZY3-90027-000. . . . .	E-4-17	HZY3-90601-030. . . . .	E-18-10-26	HZZ3-32346-R01 . . . . .	FOP-7-
HZY3-40219-013. . . . .	F-11-11	HZY3-90028-000. . . . .	E-3-36	HZY3-90602-020. . . . .	E-1-22	HZZ3-32346-R11 . . . . .	FOP-7-1-
HZY3-40225-010. . . . .	F-3-20-14	HZY3-90029-000. . . . .	E-14-10-15	HZY3-90603-020. . . . .	E-4-21	HZZ3-32346-R21 . . . . .	FOP-7-4
HZY3-40226-010. . . . .	F-3-20-15	HZY3-90030-000. . . . .	E-3-37	HZY3-90604-020. . . . .	E-4-22	HZZ3-32346-R31 . . . . .	FOP-7-1-3
HZY3-41104-C01 . . . . .	F-3-6	HZY3-90030-000. . . . .	E-3-10-8	HZY3-90652-000. . . . .	F-3-20-48	HZZ3-32347-R01 . . . . .	FOP-7-5
HZY3-41105-C01 . . . . .	F-3-7	HZY3-90030-000. . . . .	E-6-10-24	HZY3-90653-003. . . . .	F-7-4	HZZ3-35100-R11 . . . . .	FOP-1-6-38
HZY3-41116-000. . . . .	F-4-15	HZY3-90030-000. . . . .	E-13-24	HZY3-90741-000. . . . .	E-13-29	HZZ3-35100-R11 . . . . .	FOP-7-9
HZY3-41179-A00 . . . . .	F-10-12	HZY3-90030-000. . . . .	E-15-21	HZY3-90751-000. . . . .	F-2-36	HZZ3-35100-R11 . . . . .	FOP-7-1-7
HZY3-50100-A11 . . . . .	F-10-13	HZY3-90031-000. . . . .	E-3-10-9	HZY3-90752-003. . . . .	F-4-23	HZZ3-37205-R01 . . . . .	FOP-7-13
HZY3-50109-000. . . . .	F-10-14	HZY3-90031-000. . . . .	E-6-10-25	HZY3-91001-003. . . . .	E-6-10-34	HZZ3-87301-R00 . . . . .	F-12-16
HZY3-50111-020. . . . .	F-3-20-16	HZY3-90031-000. . . . .	E-14-10-16	HZY3-91056-711. . . . .	F-5-26	HZZ3-87701-R00 . . . . .	FOP-1-6-47
HZY3-50151-000. . . . .	F-10-15	HZY3-90034-000. . . . .	E-4-18	HZY3-91057-003. . . . .	F-5-27	HZZ3-87701-R40 . . . . .	FOP-1-4-18
HZY3-50153-000. . . . .	F-10-16	HZY3-90034-000. . . . .	E-15-22	HZY3-91151-000. . . . .	F-5-28	HZZ3-87701-R50 . . . . .	FOP-1-6-
HZY3-50155-000. . . . .	F-3-20-17	HZY3-90035-000. . . . .	E-9-13	HZY3-91152-003. . . . .	F-2-37	HZZ3-87703-R01 . . . . .	FOP-1-2-24
HZY3-50157-010. . . . .	F-3-20-18	HZY3-90036-000. . . . .	E-1-18	HZY3-91212-003. . . . .	E-3-42	HZZ3-87703-R81 . . . . .	FOP-1-21
HZY3-50161-610. . . . .	F-10-17	HZY3-90037-000. . . . .	E-15-23	HZY3-91251-C01 . . . . .	F-4-27	HZZ3-91252-003. . . . .	F-5-29
HZY3-50166-000. . . . .	F-10-18	HZY3-90038-000. . . . .	E-3-38	HZY3-91251-C01 . . . . .	FOP-14-3	HZZ3-91252-003. . . . .	FOP-14-4
HZY3-50168-000. . . . .	F-10-19	HZY3-90039-000. . . . .	E-13-26	HZY3-91254-003. . . . .	F-4-28	HZZ5-06325-600. . . . .	FOP-13-1
HZY3-50201-C11ZC. . . . .	F-10-20	HZY3-90040-000. . . . .	E-13-27	HZY3-91254-003. . . . .	FOP-14-5	HZZ5-06325-700. . . . .	FOP-13-
HZY3-50209-A00 . . . . .	F-10-21	HZY3-90041-000. . . . .	E-3-10-10	HZY3-91255-003. . . . .	F-2-39	HZZ5-06325-800. . . . .	FOP-13-
HZY3-50211-000. . . . .	F-10-22	HZY3-90042-000. . . . .	E-14-22	HZY3-91301-003. . . . .	E-4-23	HZZ5-16901-003. . . . .	E-18-1-12
HZY3-50214-000. . . . .	F-10-23	HZY3-90043-000. . . . .	E-14-23	HZY3-91303-000. . . . .	E-21-23	HZZ5-16906-003. . . . .	E-18-1-15
HZY3-50301-030ZC. . . . .	F-10-24	HZY3-90044-000. . . . .	E-14-24	HZY3-91304-000. . . . .	E-6-10-37	HZZ5-16915-000. . . . .	E-18-1-19
HZY3-50311-020ZC. . . . .	F-10-25	HZY3-90045-000. . . . .	E-6-10-26	HZY3-91305-003. . . . .	E-6-10-38	HZZ5-16918-003. . . . .	E-18-1-21
HZY3-50381-000. . . . .	F-10-26	HZY3-90046-000. . . . .	E-6-10-27	HZY3-91306-003. . . . .	E-6-10-39	HZZ5-16919-003. . . . .	E-18-1-23

HZZ5-32185-600. . . . .FOP-13-2  
HZZ5-32185-700. . . . .FOP-13-  
HZZ5-32185-800. . . . .FOP-13-  
HZZ5-32530-000. . . . .FOP-1-6-34  
HZZ5-32545-000. . . . .FOP-7-6  
HZZ5-32545-000. . . . .FOP-7-1-4  
HZZ5-32580-600. . . . .FOP-13-3  
HZZ5-32580-700. . . . .FOP-13-  
HZZ5-32580-800. . . . .FOP-13-  
HZZ5-37210-013. . . . .FOP-1-6-44  
HZZ5-37210-712. . . . .FOP-7-1-11  
HZZ5-37210-762. . . . .FOP-7-14  
HZZ5-38414-003. . . . .FOP-7-17  
HZZ5-38414-003. . . . .FOP-7-1-14  
HZZ5-87701-790. . . . .FOP-1-6-48  
HZZ5-91501-000. . . . .F-7-10-23





**TOHATSU CORPORATION**

**Address : 5-4,3-chome,Azusawa,Itabashi-ku,  
TOKYO,174-0051 JAPAN**

**Phone : TOKYO (03)3966-3117**

**FAX : TOKYO (03)3966-0090**

**Website : [www.tohatsu.co.jp](http://www.tohatsu.co.jp)**